

INFUSIONS[®] and METALWORKS[™] Wings Accent and Acoustical Clouds

Assembly and Installation Instructions

1. GENERAL

1.1 Product Description

Wings is a decorative ceiling element consisting of a 10 foot long extruded aluminum spine which is supported from the building structure by Electrical Metallic Tubing (EMT) and restrained from swaying by 1/16" diameter aircraft cables. Nominal 24" x 45" aluminum and translucent polycarbonate panels extend from the extrusion to complete the "wing" configuration. Wings is also available as a wall-mounted system. See Section 3 for details.

1.2 Materials and Finishes

All exposed metal components are powder coated post-manufacture, and are available in three standard colors – White, Silver Grey, and Gun Metal Grey. Plastic end caps, used to close off the ends of the spine match the metal finish. Unexposed components are not coated. Panels are available unperforated or microperforated.

1.3 System Components

Each full-size unit includes the following components for full suspended wing:

Suspension Kit

- A – Spine, extruded aluminum, powder coated (1)
- B – End cap, injection molded plastic colored to match extrusion (2)
- C – Lower bracket assembly, uncoated aluminum (3) with (6) #10 x 5/8" self-drilling screws, and (12) #10 x 3/4" setscrews
- D – Upper bracket assembly, uncoated aluminum (3) with (6) #10 x 5/8" self-drilling screws
- E – Splay wire kit (6 ea), 16' wires, galvanized steel cable with cast zinc adjusters (1) (not shown in drawing here, but included in drawing under section 2.3)
- F – Panel alignment bracket, stainless steel (8) (for MetalWorks panels only)
- G – Angle adjuster, black extruded plastic, optional (2) (see section 2.4 for more information)

MetalWorks Panel Kit

- H – Aluminum end panel, powder coated (2)
- I – Aluminum field panel, powder coated with gasket on one side (8)

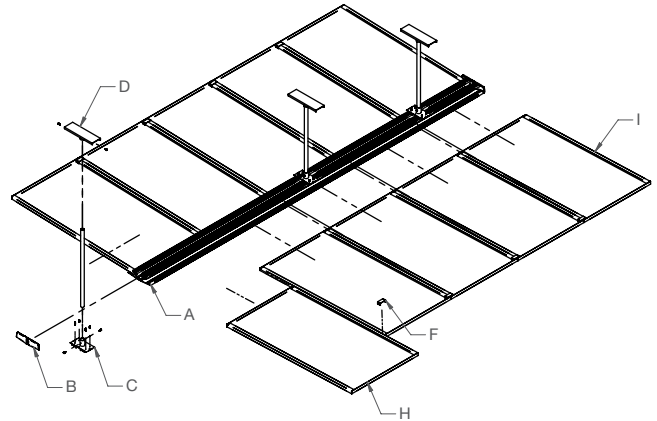

Infusions Panel Kit

- J – Polycarbonate end panel (4)
- K – Polycarbonate field panel (8)
- L – Roll of gasket (1)

Infusions Trim Kit

- M – Pieces of clear C-Channel (3)

For missing or damaged parts, please contact the Armstrong Customer Focus Center at 1 877 ARMSTRONG or your order contact.

Three sections of 3/4" thin wall EMT are required for each wing. This material and hardware to attach the wing upper bracket assemblies and splay wires to the building structure are not included in the kit.

1.4 Storage and Handling

All components shall be stored in a dry interior location and shall remain in cartons prior to installation to avoid damage. The cartons shall be stored in accordance with the instructions on the carton. Proper care should be taken when handling to avoid damage or soiling.

1.5 Site Conditions

Building areas to receive Wings shall be free of construction dust and debris. Components should only be installed in closed and acclimatized buildings. The systems cannot be used in exterior applications, where standing water is present or where moisture will come in direct contact with the system.

1.6 Installation Considerations – Full Wing Ceiling Suspension

Installation of this system requires the attachment of the three upper bracket assemblies to the building structure. The two end brackets must be located not more than two feet from the ends of the spine and the center bracket must be not more than one foot from the center.

Where obstructions in the plenum prevent placing the upper brackets as required, a sub-structure capable of withstanding the applied loads must be constructed to provide attachment for the upper brackets.

IMPORTANT: The minimum distance from the face of the spine to overhead structure is 14". This represents the amount of space required to install and remove the panels. A complete assembly weighs 65 pounds. Fasteners used to attach the upper brackets and splay wires to the structure must be capable of supporting this load with a design safety factor of 5.

Any additional weight applied to the spine must be included in the calculation for fastener strength. The maximum amount of additional load that may be applied to the spine is 56 pounds.

In all cases, the spine must be installed level to within 1/4" in 10' and must be at least 7'- 6" above the finish floor.

Wings panels may not be used to support any applied load.

WARNING: Do not use the spine to support data or power cables or wires.

Lighting fixtures may be attached to or through the center of the spine, but not to the panels. Holes bored to accommodate lighting or sprinkler installation shall be drilled from the back side of the extrusion and shall not extend more than 3/4" beyond the center line of the spine.

1.7 Fire Performance

MetalWorks™ Wings, as with other architectural features located at the ceiling, may obstruct or skew the planned fire sprinkler water distribution pattern or possibly delay or accelerate the activation of the sprinkler or fire detection systems by channeling heat from a fire either toward or away from the device. Designers and installers are advised to consult a fire protection engineer, NFPA 13, and their local codes for guidance where automatic fire detection and suppression systems are present.

2. ASSEMBLY OF FULL WING SUSPENDED FROM CEILING

2.1 Spine Installation

Determine the location for the spine and lay out the drop points for the three upper brackets.

Plumb these locations to the building structure and carefully mark the location for the fasteners.

2.2 Upper Bracket Assembly

Attach the upper brackets to the building structure.

Fully insert a length of 3/4" diameter thin wall EMT into the socket of each bracket and secure with two #10 x 5/8" lg. self-drilling screws (provided).

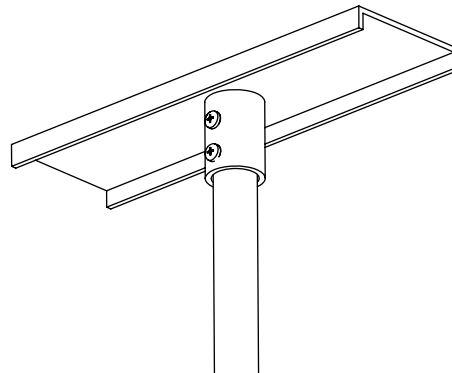

WARNING: This system and the supplied cables are designed around a maximum conduit length of 10'. Consult an engineer for guidance when greater drops lengths are desired.

When the structure to which the bracket is attached is not level, it will be necessary to bend the tubing so that it will be plumb when it connects to the spine. This is best done with a conduit bender. Work carefully to ensure that each tube is bent at the same location. Small corrections can be made by hand.

Establish a laser or level line at an elevation 2" higher than the required finish height of the spine and mark each tube. Use a tubing cutter or a Sawzall® to carefully cut the EMT to the desired length. Carefully remove all burrs on the outside of the tubes.

2.3 Install Cable Anchors

Attach six fasteners to the building structure to receive the upper end of the splay wire restraint cables.

WARNING: Make sure that the cable path provides at least 6" of clearance from all obstructions in the plenum.

Two cables are to extend upward and away from the lower end of each EMT post. The cables at the end posts are to be arrayed perpendicular to the length of the spine and not more than 45° from horizontal. The cables located at the center post are to be placed parallel to the length of the spine.

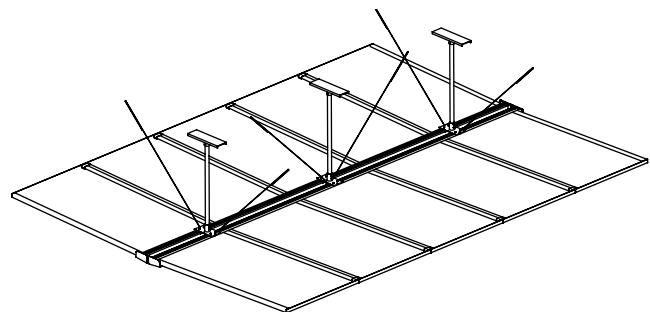

2.4 Prepare Spine

Bore any holes required for sprinklers or light fixtures through the spine, working from the back side. Up to four (4) 1-3/8" holes may be located not less than 2' apart. Dress cut edges and paint to match spine finish if these holes will be exposed to view.

The Wings Suspension Kit is supplied with optional 5 degree angle adjusters that can be used to increase the "pitch" of the installed panels. Install these adjusters now if a more pronounced V is desired. Place the angle adjuster inside the spine and press into place on the flange located at the lower outside edge of the extrusion.

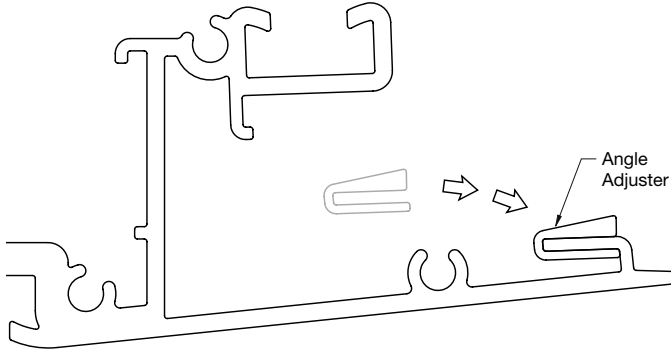

Loosely insert four setscrews (provided) into each of the three lower bracket assemblies.

Slide the lower brackets into the spine and place in the approximate locations where they will mate up with the EMT. Do not tighten the setscrews at this time.

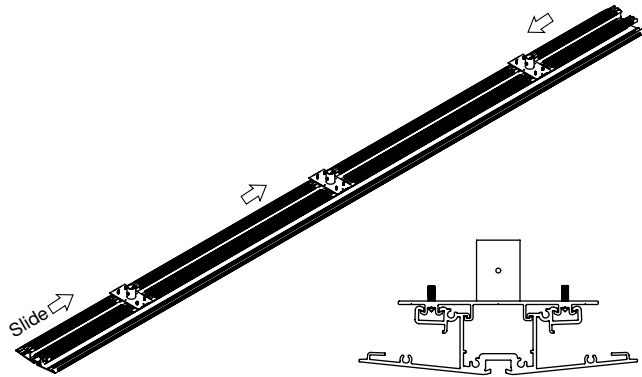

2.5 Install Spine – Requires Two People

Raise the spine into position. Make sure that the EMT posts are fully seated into the sockets on the lower brackets and secure each with two #10 x 5/8" lg. self-drilling screws (provided).

Slide the spine on the lower brackets as required to align with the construction plan. Make sure the EMT posts are plumb.

Securely tighten the setscrews installed in step 2.4.

Install the splay wire cables by inserting the plain end up through the holes provided in the lower bracket.

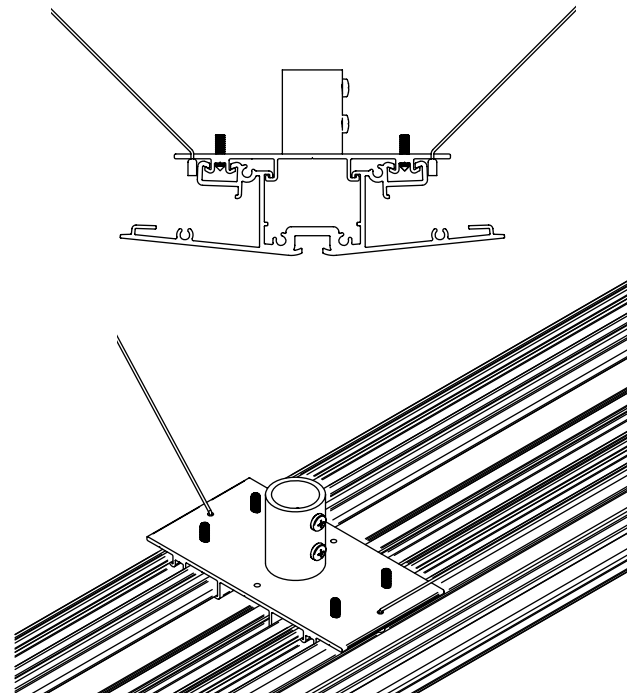

Extend the cable to the structure fastener installed in step 2.3.

Slide the end of the cable through the larger of the two openings located on the end of the Kwik Lock cable adjuster. Loop the cable through the structure anchor and then back through the other end of the adjuster.

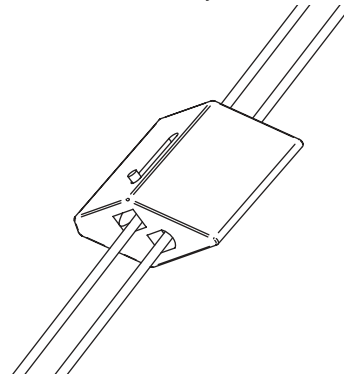

Securely tighten the cables by pulling on the free end. Make sure that the spine remains level in both directions and that all slack is removed as the cables are secured.

Trim off excess cable only after double checking for correct position and level.

WARNING: All six cables must be installed; they must not be used to support any load other than the Wings assembly. See drawing in section 2.3.

2.6 Install MetalWorks™ Panels

Panels must be installed as shipped, and are not approved for exterior applications.

Panels may NOT support any other material and may not be cut or drilled.

Locate the two end panels and set aside. These are the ones that DO NOT have a gasket adhered to one long side. Install the first field panel by inserting the notched end into the spine. Raise the outer end of the panel to allow the notch to engage the rib at the top, back of the panel channel.

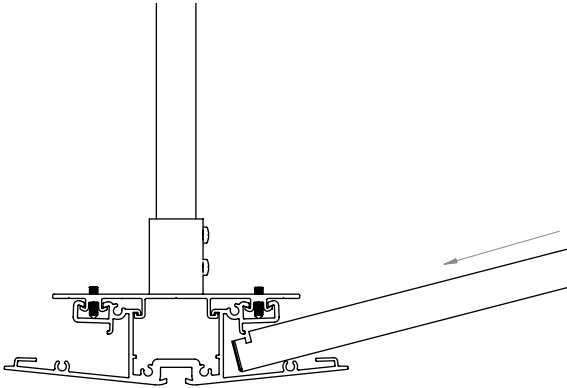

Position the plain edge of the panel 1/4" from the end of the spine.

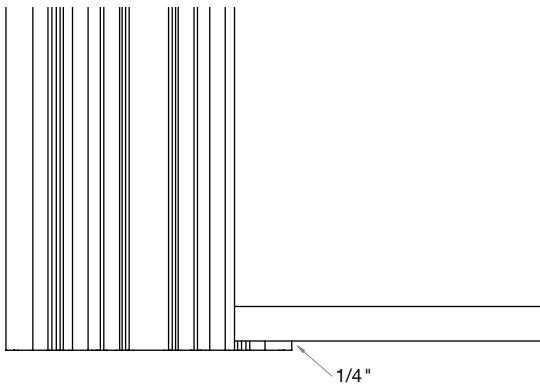

Lower the outer end of the panel to lock it in place.

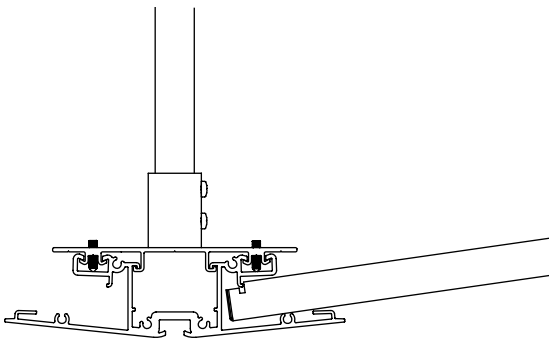

WARNING: Check to ensure that the panel notch has engaged the vertical rib located at the back of the channel.

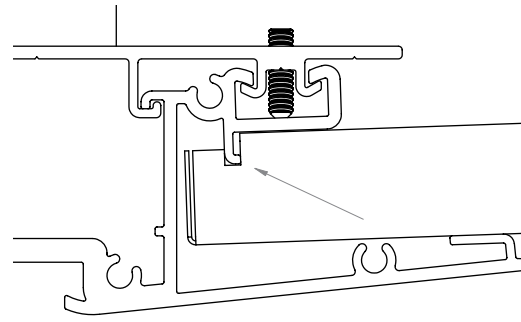

Install one of the end panels, identified in step 2.6 above, opposite the first panel.

Continue to install the remaining panels alternating from one side of the spine to the other.

2.7 Install Panel Alignment Brackets

Install a panel alignment bracket near the outer edge of each panel-to-panel joint. Engage the bracket over the top edge of the panels to secure the connection.

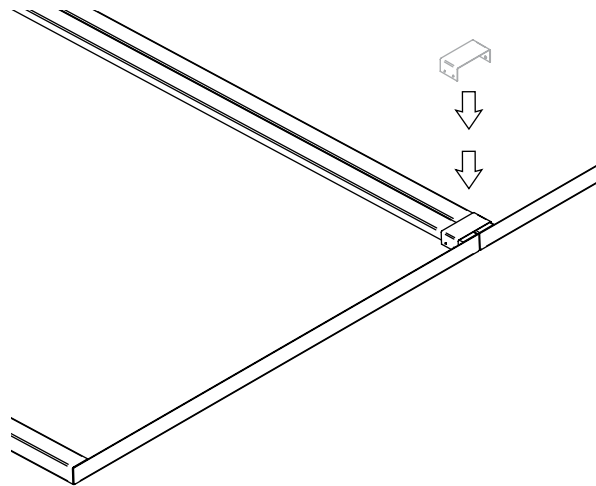

Each panel-to-panel joint MUST have an alignment clip installed.

2.8 Install Infusions® Panels

Panels are not approved for exterior use and may NOT support any other material. Panels may not be cut or drilled.

Panels have a batch code printed on them. Install with the code facing up so it is not visible from below.

Adhere the self-stick gasket to the top edge of one end of the 2' wide side of each panel.

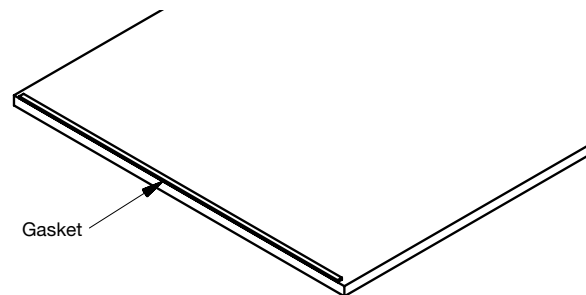

Install one of the panel ends into the suspension spine.

Position panel end with gasket behind the rib in the suspension spine.

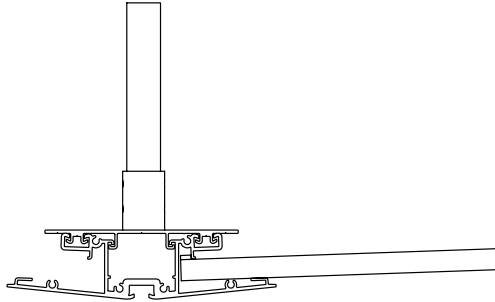

Align panels, five on each side of the suspension (three field and two end panels).

Install clear C-Channel trim with mitered corners around the outside borders of the panels (item 5846) to align panel ends.

Adjust panel seams between panels to ensure panel seams are aligned in the same direction.

2.9 Install End Caps

Complete the assembly by installing a plastic cap at each end of the spine. Align the pegs on the cap with the channels formed in the spine extrusion and press into place.

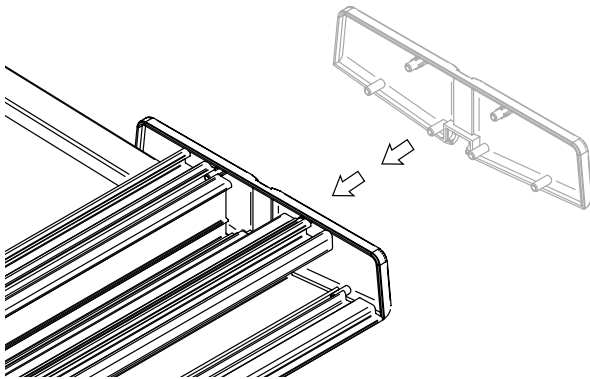

2.10 Clean and Adjust

Check and correct alignment of the spine by adjusting the splay wires as necessary.

Check and correct panel alignment. Clean surfaces with mild detergent and water and wipe dry.

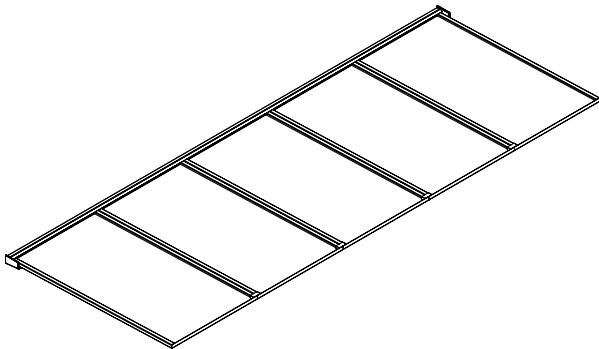

Periodic light dusting of the back of the panels may be required, if the back side of the assembly is exposed to view. Carefully dust the panels in place or take them down to clean.

3. ASSEMBLY OF HALF WING MOUNTED ON WALL

3.1 System Components

Each half-size unit includes the following components for a wall-mount installation.

Wall-Mount Suspension Kit

- Spine, extruded aluminum, powder coated (1)
- End cap, injection molded plastic colored to match extrusion (2)
- Panel alignment bracket, stainless steel (4)
- Angle adjuster, black extruded plastic, optional (1)
- #10 screws

MetalWorks™ Panel Kit

- Aluminum end panel, powder coated (1)
- Aluminum field panel, powder coated with gasket on one side (4)

Infusions® Panel Kit

- Translucent end panel (2)
- Translucent field panel (3)
- Gasketing

Infusions Trim Kit

- Pieces of clear plastic C-Channel (3)

3.2 Wings Installation for Half Module

The Wings half extrusion is mounted directly to a wall with no connection to the overhead structure. The surface to which the extrusion is to be attached must be straight and flat and the extrusion must be mounted level. Failure to comply with these requirements may cause the extrusion to be twisted, which would prevent proper alignment of the installed panels.

Self-piercing #10 screws suitable for attachment to wood or metal studs are provided with the kit. Substitute alternate hardware of similar size for attachment to other materials.

3.3 Install Spine

Prepare the wall by laying out the location for the spine (minimum 7'-6" above the floor).

Locate the studs and transfer these dimensions to the inside back of the extrusion. If there is no stud within 6" of the ends of the extrusion, add a hollow wall anchors (toggle or similar) within 6".

For solid surfaces, place the first anchor 4" from an end and then at 16" centers, ending with an anchor 4" from the opposite end.

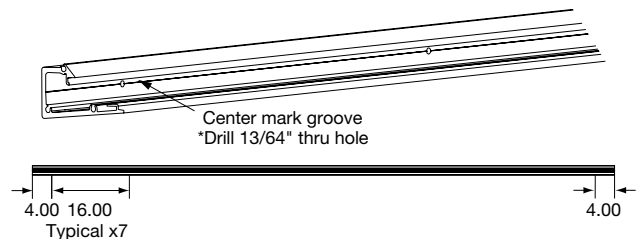

Drill holes through the back of the extrusion at the intersections of your anchor locations and the center mark which is formed into the inside back of the extrusion. Use a 13/64" diameter bit for the provided screws. Size holes for alternate hardware to provide close clearance.

Make necessary preparations for alternate hardware and attach the spine to the wall. Be sure to maintain level. If the self-piercing screws will not penetrate the studs, drill pilot holes with a #21 (0.159") drill bit. Shim the extrusion as necessary when the wall surface is not flat and straight.

3.4 Install Angle Adjuster

A black plastic angle adjuster is supplied with the extrusion. When desired, it is added onto the extrusion to increase the angle of the panels.

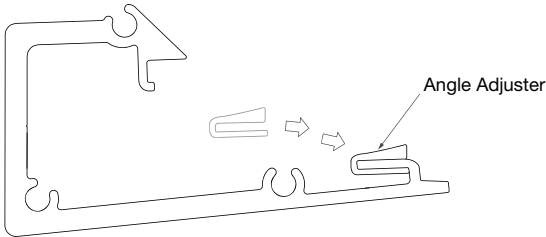

3.5 Install MetalWorks™ Panels

Panels must be installed as shipped, and are not approved for exterior applications

Panels may NOT support any other material and may not be cut or drilled.

Locate the end panel and set aside. This is the one that DOES NOT have a gasket adhered to one long side.

Install the first field panel by inserting the notched end into the spine. Raise the outer end of the panel to allow the notch to engage the rib at the top, back of the spine.

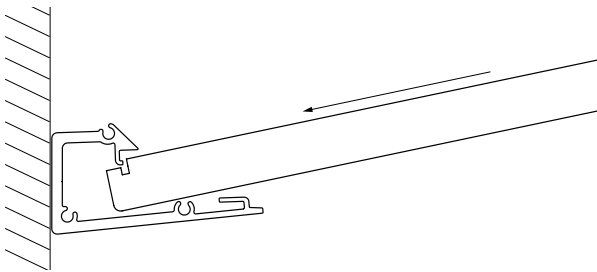

Position the plain edge of the panel 1/4" from the end of the spine.

Lower the outer end of the panel to lock it in place.

WARNING: Check to ensure that the panel notch has engaged the vertical rib located at the back of the channel.

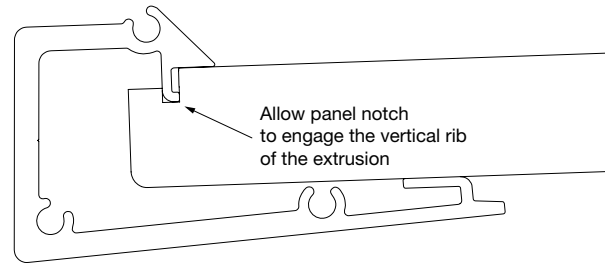

Continue to install the remaining panels.

Install the end panel, identified in step 3 above.

3.6 Install Panel Alignment Brackets

Install a panel alignment bracket near the outer edge of each panel-to-panel joint.

Engage the bracket over the top edge of the panels to secure the connection.

Each panel-to-panel joint **MUST** have an alignment clip installed.

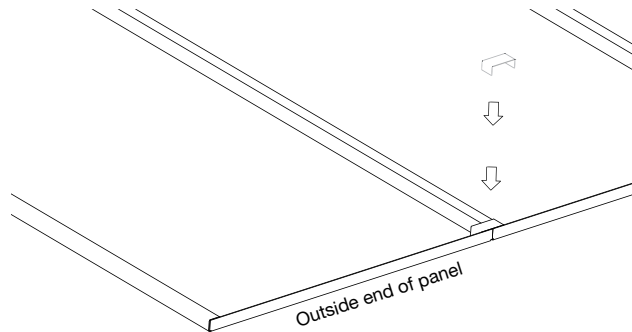

3.7 Install Infusions® Panels

Panels are not approved for exterior use and may NOT support any other material. Panels may not be cut or drilled.

Panels have a batch code printed on them. Install with the code facing up so it is not visible from below.

Adhere the self-stick gasket to the top edge of one end of the 2' wide sides of each panel.

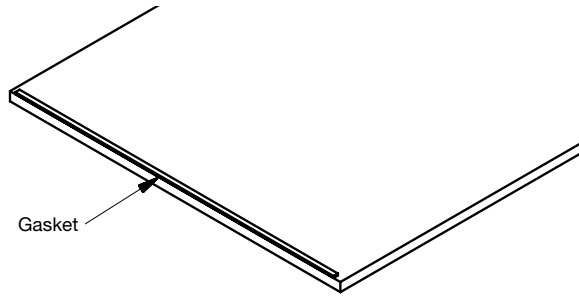

Install one of the panel ends into the suspension spline.

Position panel end with gasket behind the rib in the suspension spline.

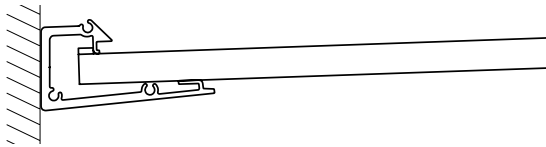

Align panels, five on each side of the suspension (three field and two end panels).

Install clear C-Channel trim with mitered corners around the outside borders of the panels (item 5847) to align panel ends.

Adjust panel seams between panels to ensure panel seams are aligned in the same direction.

3.8 Install End Caps

Complete the assembly by installing a plastic cap at each end of the spine. Align the pegs on the cap with the channels formed in the spine extrusion and press into place.

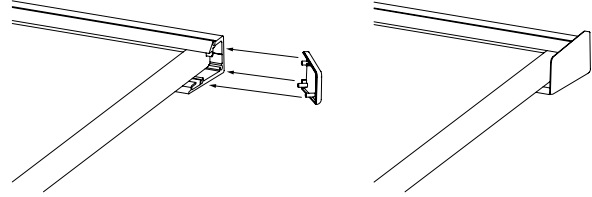

3.9 Clean And Adjust

Check and correct panel alignment. Clean surfaces with mild detergent and water and wipe dry. Periodic light dusting of the back of the panels may be required if the back side of the assembly is exposed to view. Carefully dust the panels in place or take them down to clean.

4. SEISMIC INSTALLATIONS

Full-scale dynamic shake table testing was successfully completed for full and half Wings assemblies installed as described in this document. Documentation to support this installation is available if required. Review details with the local Authority Having Jurisdiction (AHJ) prior to installation.

MORE INFORMATION

For more information, or for an Armstrong representative, call 1 877 ARMSTRONG.

For complete technical information, detail drawings, CAD design assistance, installation information, and many other technical services, call TechLineSM at 1 877 ARMSTRONG or FAX 1 800 572 TECH.

For the latest product selection and specification data, visit armstrong.com/wings.

Sawzall[®] is a registered trademark of the Milwaukee Electric Tool Company. All other trademarks used herein are the property of AWI Licensing Company and/or its affiliates.

© 2014 AWI Licensing Company • Printed in the United States of America

BPLA-297520-914



CEILING SYSTEMS