

TECTUM® Direct-Attach Ceiling and Wall Panels

Assembly and Installation Instructions for 1" Thick Direct-Attach Wall and Ceiling Panels

TECTUM® DIRECT-ATTACH CEILING AND WALL PANELS – STANDARD ITEMS:				
Long Edges Beveled/Short Edges Square				
Item No. *	Item Name	Included with panels	Sold by the:	SF per Pallet
8180T10_ _ _	47-3/4 x 96 x 1" Panel	–	Pallet	1,152
8181T10_ _ _	23-3/4 x 96 x 1" Panel	–	Pallet	1,152
8182T10_ _ _	23-3/4 x 48 x 1" Panel	–	Pallet	572
Long Edges Beveled/Short Edges Beveled				
8173T10_ _ _	47-3/4 x 96 x 1" Panel	–	Pallet	1,152
8174T10_ _ _	23-3/4 x 96 x 1" Panel	–	Pallet	1,152
8175T10_ _ _	23-3/4 x 48 x 1" Panel	–	Pallet	572
TECTUM DIRECT-ATTACH CEILING AND WALL PANELS – INSTALLATION ACCESSORIES*				
*Note: Fasteners required vary based on project details. Reference Section 4 for guidance.				
Item No. *	Item Name	Included with panels	Sold by the:	Pcs per Ctn
8187L16_ _ _	Sharp Point Screw #6 x 1-5/8"	No	Carton	1000 pcs
8188L16_ _ _	Drill Point Screw #6 x 1-5/8"	No	Carton	1000 pcs
8189L22_ _ _	CMU Screw – 2-1/4" Painted Head	No	Carton	500 pcs
1222	Truss Fastening Kit – Field Paintable	No	Carton	20 pcs
1222WH	Truss Fastening Kit White	No	Carton	20 pcs
1222BL	Truss Fastening Kit Black	No	Carton	20 pcs
	Wood or Metal Furring Strips	Not sold by Armstrong Ceilings		

* When specifying or ordering, include the appropriate 3-digit color suffix TNA = Natural TWH = White (e.g. 8182T10 I W H). For four-sided beveled edge panels, special sizes and colors, call TechLine at 1 877 276 7876.

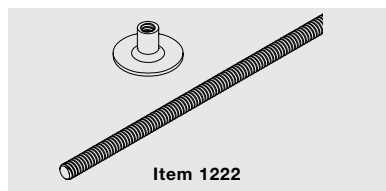
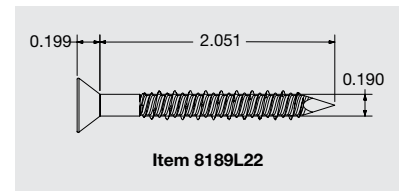
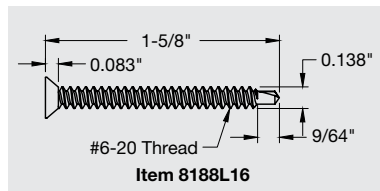
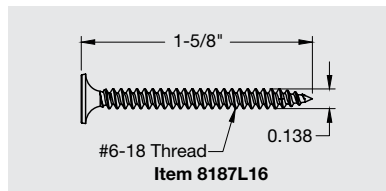

1. GENERAL

1.1 Product Description

Tectum® Direct-Attach ceiling and wall panels are highly impact-resistant panels made of Aspen wood fibers held together with a cementitious binder. Standard Tectum Direct-Attach panels for walls and ceilings are 1" thick and available in nominal sizes of 2' x 4', 2' x 8', and 4' x 8'. Items 8180, 8181, and 8182 are beveled on the two long sides. Items 8173, 8174, and 8175 are beveled on all four sides.

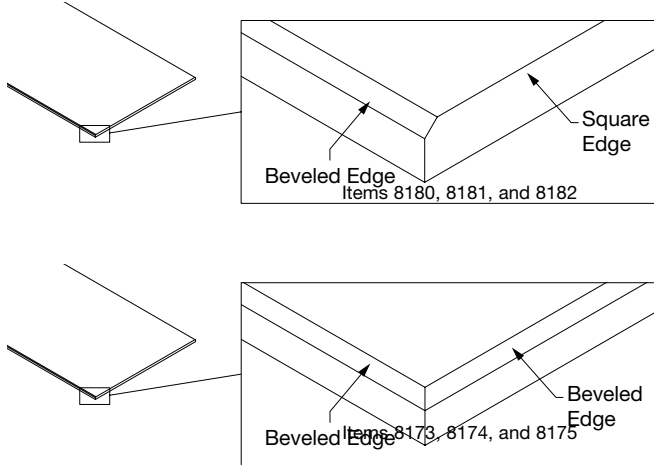

Custom panels are available in additional sizes and thicknesses upon request (Contact TechLine).

Standard panels are available in two colors: White and Natural. Please note, Natural and White panels will show normal color variation due to the wood fibers.

Tectum Direct-Attach panels are installed using Tectum screws on furring or other appropriate fasteners when attaching directly to the structure. See Sections 4 & 5 for more details on installation. Dependent on mounting method, standard ceiling and wall 1" thick Tectum panels provide an NRC (Sound Absorption) ranging from 0.40 to 0.85. Thicker custom options can provide an NRC of up to 1.0 (Contact your local Armstrong Ceilings distributor). Panels can be field cut and field painted up to six times without impacting acoustic or fire performance (see Section 7.5).

1.2 Safety

This product is made of wood fibers and cementitious binder. Sawing, sanding, or machining these products can produce wood dust and crystalline silica. Airborne dust can cause respiratory, eye, and skin irritation. Respirable wood dust and crystalline silica are classified as carcinogens. Personal protective equipment includes safety glasses or goggles, and impervious gloves. Respiratory protection may be required and depends on how the product is being cut and handled. Job site environmental conditions must be evaluated in determining what type of respiratory protection is required. In all cases, cutting is to be performed in a well-ventilated area and power tools must be equipped with a dust collection system. Refer to the Safety Data Sheet www.armstrongceilings.com/tectum for additional information.

1.3 Warranty

Failure to follow the Armstrong Ceilings recommended installation instructions in effect at the time of installation may void the product and/or ceiling system warranty.

1.4 Surface Finish

Tectum panels are made of wood fibers within a cementitious binder. White panels are finished with a latex-based paint. Due to the unique porous composition of Tectum panels, they can be field painted up to six times without negatively impacting acoustic or fire performance.

NOTE: The edges of Tectum panels are not fully painted. For installations where finished painted edges are required see Section 7.5 for field painting guidance.

1.5 Storage & Handling

Panels should be stored in a dry interior location and shall remain in cartons prior to installation to avoid damage. The cartons should be stored in a flat, horizontal position.

Proper care must be taken when handling to avoid damage and soiling. Do not store in unconditioned spaces with humidity greater than 85% or lower than 25% RH, and temperatures lower than 32°F or greater than 120°F. Panels must not be exposed to extreme temperatures, for example, close to a heating source or near a window where there is direct sunlight.

1.6 Site Conditions

Tectum panels are required to reach room temperature and have stabilized moisture content for a minimum of 72 hours before installation. They should not, however, be installed in spaces where the temperature is lower than 32°F or greater than 120°F, or humidity conditions are greater than 85% or lower than 25% RH. Panels must not be exposed to extreme temperatures, for example, close to a heating source or near a window where there is direct sunlight. All wet work (plastering, concrete, etc.) must be complete and dry.

1.7 HVAC Design & Operation, Temperature & Humidity Control

Real wood and wood composite products are natural building materials and they will react to changes in humidity. Spaces with installed product should be maintained with humidity in a range between 25% and 85% RH and temperatures in a range between 32°F and 120°F. (Wood tends to contract with lower humidity and expand with higher humidity.)

Cementitious wood fiber panels may also have a tendency to warp, twist, or bow, due to the natural stresses in the components and these humidity changes. Be aware of these natural tendencies when evaluating the products. It is also necessary for the area to be enclosed and for the HVAC systems to be functioning and in continuous operations for the life of the product. All wet work (plastering, concrete, etc.) must be complete and dry. Standard 1" Tectum panels cannot be used in exterior applications. Contact TechLine for information on custom Tectum products available for exterior installations.

1.8 Colors

Standard Tectum panels are available in Natural and White finishes. Due to the natural variation of Tectum wood fibers, Natural and White panels will have normal color variation from panel-to-panel and within panels.

Panels can be field painted up to six times without losing their acoustical or fire performance. See Section 7.5 for field painting guidelines. Factory-finished custom colors are also available (Contact TechLine).

2. DESIGN CONSIDERATIONS

2.1 Directionality

Tectum® Direct-Attach panel items 8180, 8181, and 8182 are beveled on the two long edges with square ends. Panels should be installed beveled edge to beveled edge. In installation layouts where this is not possible, ashlar patterns are required. For increased design flexibility, items 8173, 8174, and 8175 have a beveled edge on all four sides.

2.2 Edges

Exposed edges of an installation are not factory painted. See Section 7.5 for guidance on field painting.

2.3 Pool Installations

1" thick Tectum Direct-Attach ceiling and wall panels are not to be used in pool areas or other high-humidity areas where standing water is present. Contact TechLine for information on custom Tectum products available for pool installations.

2.4 Exterior Installations

1" thick Tectum Direct-Attach ceiling and wall panels are not intended for exterior use.

2.5 Direct Attachment

Tectum Direct-Attach panels are mechanically fastened to furring (metal or wood) or direct to structure using appropriate fasteners. See Installation Sections 4 & 5 for different mounting methods. Direct-Attach panels are approximately 1.65 lbs/SF. Correct fasteners should consider total system weight. For acoustical solutions, reference C-20 and C-40 mounting. **Do not countersink screws or fasteners into panel face.** The type and position of framing and furring will be specified by the contractor.

3. TECTUM ACCESSORIES

3.1 Screws

Armstrong® Ceiling and Wall Systems offers three types of screws for many common installation methods. For specific installation instructions, including which screw for furring to structure connection and spacing, please see Section 4.

Sharp point screws (item 8187L16) are 1-5/8" long and are available in coordinating factory-finished White (suffix TWH) or Natural (suffix TNA). For 20- and 25-light-gauge steel framing, wood furring, or Armstrong Ceilings drywall grid, use 1-5/8" sharp point drywall screws.

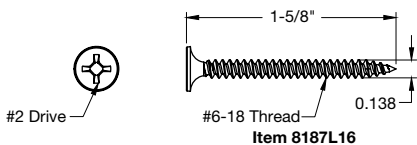

Drill point screws (item 8188L16) are 1-5/8" long and are available in coordinating factory-finished White (suffix TWH) or Natural (suffix TNA). For 20-gauge structural and heavier steel decking or framing, use 1-5/8" self-drilling drywall screws.

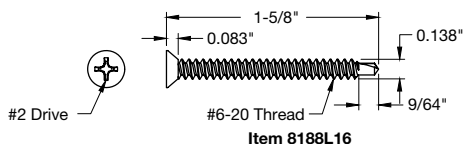

CMU Screws (item 8189L22) are 2-1/4" long and are available in coordinating factory-finished White (suffix TWH) or Natural (suffix TNA). For hollow block CMU (Cement Masonry Unit or breeze/cinder block) structures, use 2-1/4" masonry screws. See specific installation guidance in Section 4.1.

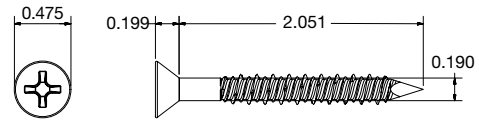

Item 8189L22

To attach Tectum panels to structures or surfaces not listed in this section, please contact a fastener manufacturer, such as Hilti™, Fastenal®, or TapCon® to obtain guidance and engineering data support.

FASTENER REFERENCE CHART

SCREW LENGTH	PANEL THICKNESS
Sharp Point	
1-5/8"	1" Thick Panel
2-1/4"	1-1/2" Thick Panel
3"	2" Thick Panel
Drill Point	
1-5/8"	1" Thick Panel
2-3/8"	1-1/2" Thick Panel
3"	2" Thick Panel
CMU	
2-1/4"	1" Thick Panel
2-3/4"	1-1/2" Thick Panel
3-1/4"	2" Thick Panel

3.2 Truss Fastening Kit

The Truss Fastening Kit contains threaded rod and weld nuts. The threaded rod is designed to pierce panels and be capped on both ends by the weld nut. The weld nut's head acts as a washer once properly installed. Each kit contains 20 threaded rods and 40 weld nuts. (24" x 48" Tectum panels require 4 fasteners).

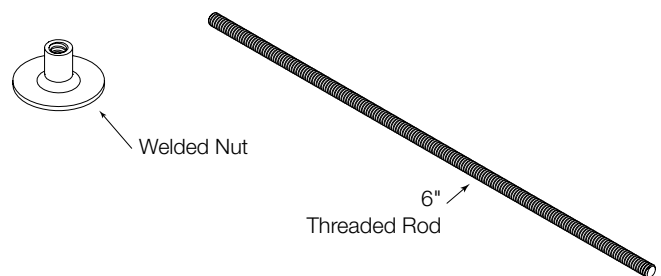

4. INSTALLATION OPTIONS

There are three different installation options for use with Tectum panels. These options are:

- Screw attached to furring or DGS that is secured to structure (ceiling or walls)
- Installed on an I-Beam – screw attached to furring that is secured to the I-Beam (see Section 4.10)
- Installed on a steel truss with the Truss Fastening Kit (see Section 4.11)

For Tectum® Direct-Attach panels, one of the most common application methods for Tectum interior panels is screw attachment to furring. The furring can be either wood or metal. Direct-Attach panels are approximately 1.65 lbs/SF. Consider total system weight when determining fasteners. The furring enables improved sound absorption and allows the installer to fasten in areas where there could otherwise be obstructions. The use of screw attachment for interior panels is widely accepted. The proper installation of the screws results in an installation where the heads are difficult to find even when viewed from a short distance. The Phillips flat head screws are painted to match either the painted White panels or the Natural panels. The screws are installed so that the screw head is flush with the surface of the Tectum panel. **Do not countersink the screw heads.** The texture of Tectum panels helps hide the screw head. This installation section will review the different mounting methods and fastener recommendations.

The NRC requirements will dictate what mounting method should be used. Verify specifications or drawings to determine project requirements. There are four direct mounting methods and each of them will have specific installation requirements so the Tectum™ system can meet project NRC specifications.

NOTE: Tectum panel edges are not factory painted. In installations where the sides of the panels are to be exposed they may need to be addressed with trim or field painting, referenced in Section 7.5.

4.1 Mounting Method A

Mounting Method A requires installing panels directly to a wall structure with no furring or space behind the Tectum panels. Please consult this section for type of screw (CMU/Drill Point/Sharp Points) and Section 4.6 for spacing requirements (for both Standard Interior and High-Impact/Abuse applications).

Because ceiling and wall structure materials vary greatly, Armstrong® World Industries does not offer fasteners for all project applications, but does provide fasteners for the most common structures. Depending on what the substrate is, there are different recommendations for which fastener to use.

For one of the most common wall structures, CMU (hollow Cement Masonry Unit, or breeze/cinder block), use Tectum 2-1/4" CMU Screw (item 8189L22). While the CMU screw will work in a majority of concrete block applications, it is important to note that it will not work with all concrete. It is difficult or impossible to use this screw with some poured or precast concrete. Work with a fastener manufacturer to determine best fastener for your application and to acquire engineering reports regarding performance. Contact Armstrong Ceilings TechLine or TapCon® if specific guidance is needed related to drill bits, anchors, or general CMU screw installation.

For structures other than hollow CMU, contact a fastener manufacturer, such as Hilti™, Fastenal®, or Tapcon® to get guidance and engineering support data on the fastener type that will meet pull-out requirements for your building code.

IMPORTANT NOTES:

Power Actuated Fasteners: Do not use power actuated fasteners to directly attach Tectum panels to masonry surfaces. If power actuated fasteners are necessary they should be used on the furring/hat channel and panels screw-attached to the furring as described in steel framing and wood furring Section 4.2.

Exterior Masonry Walls: In the event that you encounter uninsulated exterior walls, or if you are uncertain of the insulation conditions of the wall, use furring strips to ensure an air gap between panels and the structure to minimize unwanted condensation-related issues.

For fastener spacing requirements for standard interior and high-impact spaces, see Section 4.6.

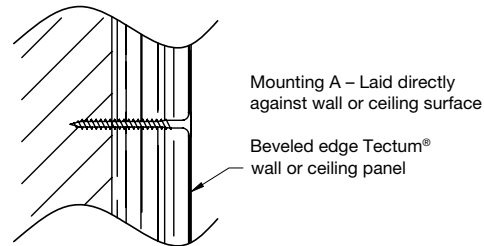

4.2 Mounting Method D-20

The D-20 Direct-Attach mounting method includes beveled-edge wall panels laid on 3/4" furring strips, or Drywall Grid (item 8906 main beam and XL8945 cross tees) to maintain air gap between structure and back of the Tectum panels. The furring must be attached to structure in a method that supports the full weight of the panels **per the requirements specified in Section 4.5.** Contact a fastener manufacturer, such as Hilti™, Fastenal® or TapCon® to ensure the correct fastener for the structure type, since structure fastener requirements can vary. Due to joist/stud spacing in most jobs, to meet fastener layout requirements furring strips are recommended to ensure a secure fastening location for the panels. If you are attaching to existing drywall, all fasteners must go into a stud, drywall grid, or other structural component. It is the responsibility of the contractor to locate these elements in either ceiling or wall applications.

Please consult the following sections for attaching the Tectum panels to the type of furring selected (Drill Point/Sharp Points) and Section 4.6 for spacing requirements (for standard interior or high-impact/abuse spaces):

Attach Tectum panels directly to 3/4" wood or metal hat channel furring (see Section 4.6 for screw spacing/guidance):

- Wood furring: In a D-20 mounting, to attach to wood furring, use Tectum 1-5/8" sharp point screws (item 8187L15) with coordinating painted face
- Light Gauge (20-25 gauge) Metal furring/framing: In a D-20 mounting, attach to thin gauge metal furring with Tectum 1-5/8" sharp point screws (item 8187L15) with coordinating painted face
- Drywall Grid furring: In a D-20 mounting, attach to thin-gauge metal furring with Tectum 1-5/8" sharp point screws (item 8187L15) with coordinating painted face
- Heavy-gauge metal furring: In a D-20 mounting, attach to heavy-gauge metal furring with Tectum 1-5/8" drill point screws (item 8188L15) with coordinating painted face

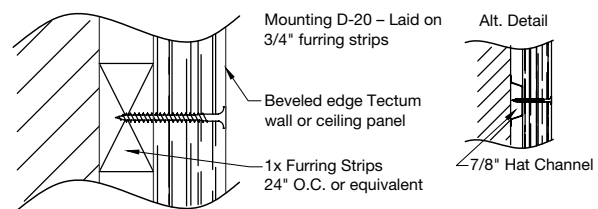

4.3 Mounting C-20

The C-20 Direct-Attach mounting method includes beveled edge wall panels laid on 3/4" furring strips with 1", 3-lb. density fiberglass batt insulation between the furring, which increases the acoustic absorption of the installed space (NRC). The furring must be attached to structure in a method that supports the full weight of the panels **per the requirements specified in Section 4.5**. Contact a fastener manufacturer, such as Hilti™, Fastenal®, or TapCon® to ensure the correct fastener for the structure type, since structure fastener requirements can vary. Due to joist/stud spacing in most jobs, to meet fastener layout requirements furring strips are recommended to ensure a secure fastening location for the panels. If you are attaching to existing drywall, all fasteners must go into a stud, drywall grid, or other structural component. It is the responsibility of the contractor to locate these elements in either ceiling or wall applications.

Please consult the following sections for attaching the Tectum® panels to the type of furring selected (Drill Point/Sharp Point) and Section 4.6 for spacing requirements (for standard interior or high-impact/abuse spaces):

Attach Tectum panels directly to 3/4" wood or metal furring (see Section 4.6 for screw spacing/guidance):

- Wood furring: In a C-20 mounting, to attach to wood furring, use Tectum 1-5/8" sharp point screws (item 8187L15) with coordinating painted face
- Light-gauge (20-25 gauge) metal furring/framing: In a C-20 mounting, attach to light-gauge metal furring with Tectum 1-5/8" sharp point screws (item 8187L15) with coordinating painted face
- Drywall grid furring: In a C-20 mounting, attach to thin-gauge metal furring with Tectum 1-5/8" sharp point screws (item 8187L15) with coordinating painted face
- Heavy-gauge metal or structural steel: In a C-20 mounting, attach to heavy-gauge metal furring with Tectum 1-5/8" drill point screws (item 8188L15) with coordinating painted face

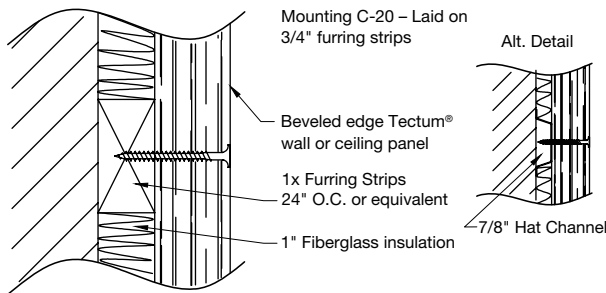

4.4 Mounting C-40

The C-40 Direct-Attach mounting method includes beveled-edge wall panels laid on 1-1/2" furring strips with 2-1/2" batt insulation between the furring, which increases the acoustic absorption of the installed space (NRC). The furring must be attached to structure in a method that supports the full weight of the panels **per the requirements specified in Section 4.5**. Contact a fastener manufacturer, such as Hilti™, Fastenal®, or TapCon® to ensure the correct fastener for the structure type, since structure fastener requirements can vary.

Due to joist/stud spacing in most jobs, to meet fastener layout requirements furring strips are recommended to ensure a secure fastening location for the panels. If you are attaching to existing drywall, all fasteners must go into a stud, drywall grid, or other structural component. It is the responsibility of the contractor to locate these elements in either ceiling or wall applications.

Please consult the following sections for attaching the Tectum panels to the type of furring selected (Self-drilling/Sharp point) and Sections 4.5 and 4.6 for spacing requirements (for standard interior or high-impact/abuse spaces):

Attach Tectum panels directly to 3/4" wood or metal furring (see Section 4.6 for screw spacing/guidance):

- Wood furring: In a C-40 mounting, to attach to wood furring, use Tectum 1-5/8" sharp point screws (item 8187L15) with coordinating painted face
- Light-gauge (20-25 gauge) metal furring/framing: In a C-40 mounting, attach to thin-gauge metal furring with Tectum 1-5/8" sharp point screws (item 8187L15) with coordinating painted face
- Drywall Grid furring: In a C-40 mounting, attach to thin-gauge metal furring with Tectum 1-5/8" sharp point screws (item 8187L15) with coordinating painted face
- Heavy-gauge metal furring or structural steel: In a C-40 mounting, attach to heavy-gauge metal furring with Tectum 1-5/8" drill point screws (item 8188L15) with coordinating painted face

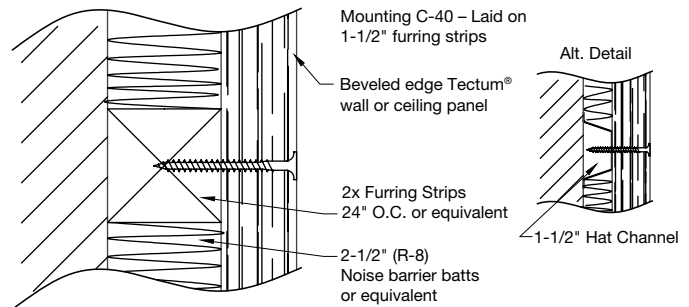

4.5 Panel Direction & Fastener Layout

Recommended screw spacing is such that one screw supports one square foot to three square feet of panel. The 1" thick standard Direct-Attach ceiling and wall panel has a weight of 1.65 lbs/SF. It is the contractor/installer's responsibility to ensure type of fastener and placement is able to carry the system weight. Additionally, the Tectum panel surface is not intended to support additional weight. Because the pull-through resistance of the screw head is adequate, no washers or adhesive application is required.

Horizontal Wall Panel Installation

Tectum® panels should be fastened a minimum of 24" O.C. starting at the edge of the panels. When furring is used it should be installed perpendicular to the long side of the panel. Tectum panels are required to be installed in an ashlar pattern (staggered end joints). Furring is required at the ends of the panels.

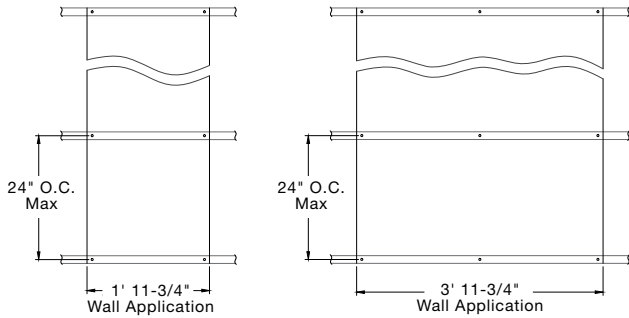

Vertical Wall Panel Installation

Tectum panels should be attached at a maximum 24" O.C. on the vertical dimension and 23-3/4" on the horizontal dimension.

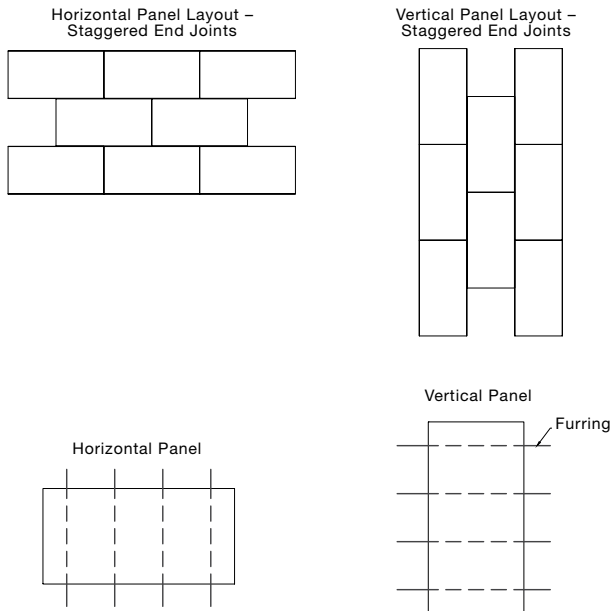

4.6 Screw Placement for ALL Mounting Methods

Tectum interior panels are typically installed over furring but the same screw pattern should be used for a Type A direct mounting. The recommended method is for the furring to be spaced not over 24" O.C. and perpendicular to the panel direction in standard use spaces. Please see Section 4.9 for screw spacing recommendations for high impact areas. Furring is required at the panel ends. The attachment of the furring and the furring must be designed to support the weight of the panels. If furring must be installed parallel to the panel direction, the spacing must match the panel width.

A panel 47-3/4" must have mid-width furring. Spacing should be as follows for furring parallel to Tectum panels:

- 23-3/4" width 23-3/4" center-to-center spacing
- 47-3/4" width 23-7/8" center-to-center spacing

When attaching to furring use painted head drywall screws. For wall applications on 23-3/4" wide panels, two screws per furring crossing are required; for 47-3/4" wide panels, three screws per furring crossing are required. The screws are to be spaced 1" from the panel edges and where three (3) are required, the third screw is centered. For ceiling applications using 23-3/4" wide panels, three (3) screws per furring crossing are required. For ceiling applications using 47-3/4" wide panels, five (5) screws per furring crossing are required.

Standard Wall Panel Attachment

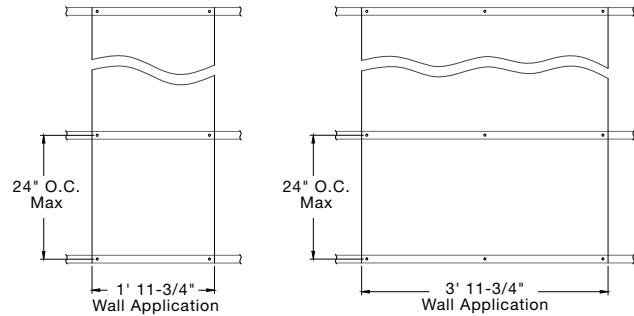

High-Impact Wall Panel Attachment

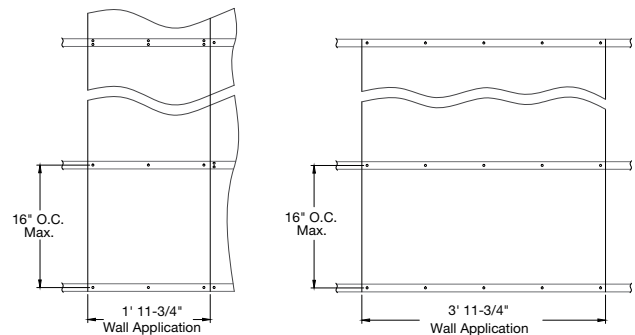

NOTE: Short side of panel (panel width) is undersized at 23-3/4" or 47-3/4", while long side of the panel is 48" or 96".

4.7 Staggered End Joints (Ashlar Pattern)

All Tectum wall panels are required to have staggered end joints if more than one panel is installed.

4.8 Field Cutting

Tectum panels are easily cut using standard wood cutting tools. The short ends of panels (23-3/4" side for 2' x 4' and 47-3/4" side for 4' x 8' panels) will be square edges from the plant and will require a hand router with a 1/4" bevel bit to replicate the 1/4" bevel in the field, if required.

4.9 High-Impact Areas

Furring or fastener attachment is required at 16" O.C. in lieu of 24" O.C. as described above in section 4.6 for all 1" panels.

4.10 Attachment to I-Beam

Tectum® panels are mounted to I-Beams using metal furring channel and 8187L16 sharp point screws. This installation method is limited to 1" thick panels, no more than 24" in height when installed horizontally. Panels can only be installed in single panel height rows, with the length of the panel in a horizontal orientation, and the short edges of each panel end to end. Panels can be installed with ends butted up or installed with a reveal between ends. See Sections 4.2, 4.5, and 4.6 for mounting method guide regarding furring and screw placement.

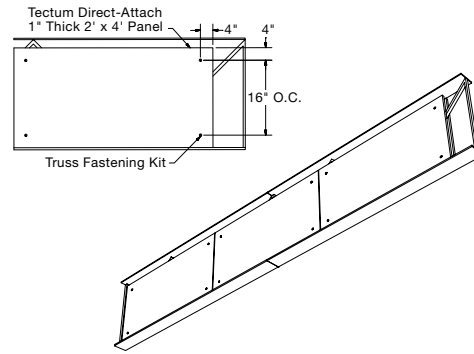
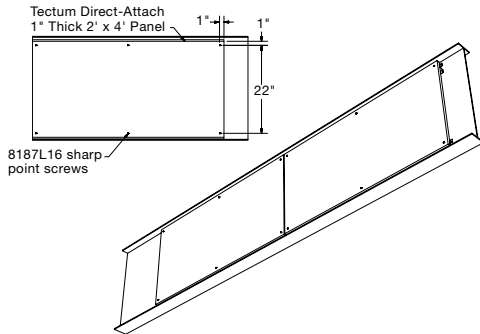

4.11.1 Truss Requirements:

- The truss must have a horizontal flange on the bottom edge greater than the width of the panel.
- It must be no smaller than 8" in height between top and bottom flanges.
- Webs/Braces of the truss can be no more than 4" (max dimension of air gap between panels that Truss Fastening Kit will accommodate).
- It must have a sufficient number of webs or braces for the panels to be fastened against. It is recommended that there are at least two webs or braces contacting each pair of panels when installed, thereby eliminating any risk of movement.

4.10.1 I-Beam Requirements:

- The I-Beam web must be tall enough to accommodate two rows of furring spaced at least 6" O.C. up to a maximum of 22" O.C. running the same direction as the beam
- Fastener connections of the furring channel to the I-Beam structure are specified by the contractor and must follow the manufacturer's instructions and reference code

4.10.2 Installation Steps:

Spacing of the furring will be based on the panel size and necessary fastener locations. See Section 4.6 for instructions on mounting screw locations. Furring must be installed accordingly so that it is behind each fastener location.

Once your furring is installed, make sure you have sufficient clearance to install your panel between the flanges of the I-Beam. Measure the space between the flanges of the I-Beam to determine if the panels need to be cut to size. It is recommended that the panel have at least 1" of clearance at the top since I-Beam flanges taper inwards in most cases. If cuts are required see section 1.2 for cutting instructions and safety recommendations.

You can either rest the panels on the bottom flange of the I-Beam as a method of aligning panels end to end, or, if installing the panels up off the flange, use a laser or string line to ensure a level installation. Panel ends are intended to be butted up against each other for the most pleasing visual.

4.11 Attachment to Truss

Tectum panels can be mounted to flat trusses using the Truss Fastening Kit. This installation method is limited to 1" thick panels, no larger than 24" x 48". The panels must be installed in pairs and cover both sides of the truss. Panels can only be installed in single panel height rows, with the length of the panel in a horizontal orientation, and the short edges of each panel end to end. Panels can be installed with ends butted up or installed with a reveal between ends.

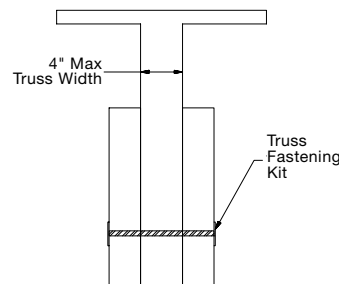
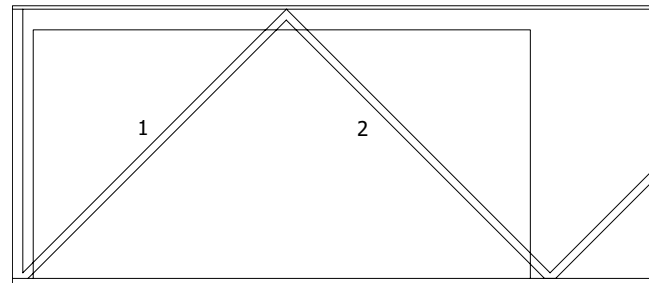

4.11.2 Installation Steps:

Make sure you have sufficient clearance to install your panels between the flanges of the truss. The panels should rest on the bottom flange of the truss and have at least 1/2" of clearance between the panel and the top flange of the truss. If your panel does not fit, you must cut it down to size.

It is recommended to have two installers for truss installations. Once the panels are cut to fit, pre-mark the locations for your truss fastening kit onto the panel. Four (4) fasteners are required per panel. It is required to have one (1) fastener located near each corner of the panel, approximately 4" in from each edge.

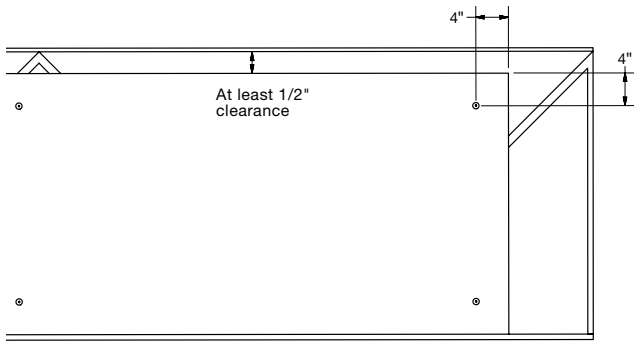

Screw one washer head onto the threaded rod such that it sits flush with the end of the rod. Once in place, crimp the washer so it cannot be unscrewed. Do this for all needed hardware.

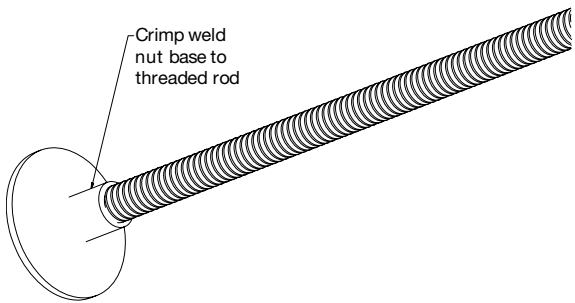

Next, move your panels into the truss (one on each side of the webs) and align your two panels together. With the marked side of the panel facing you, take your threaded rod/crimped washer and tap the uncapped side through the panel, the air gap between panels, and out through the panel on the other side. Once through, cap off the other side with a washer and hand tighten against panel. Cut off whatever remains of the threaded rod.

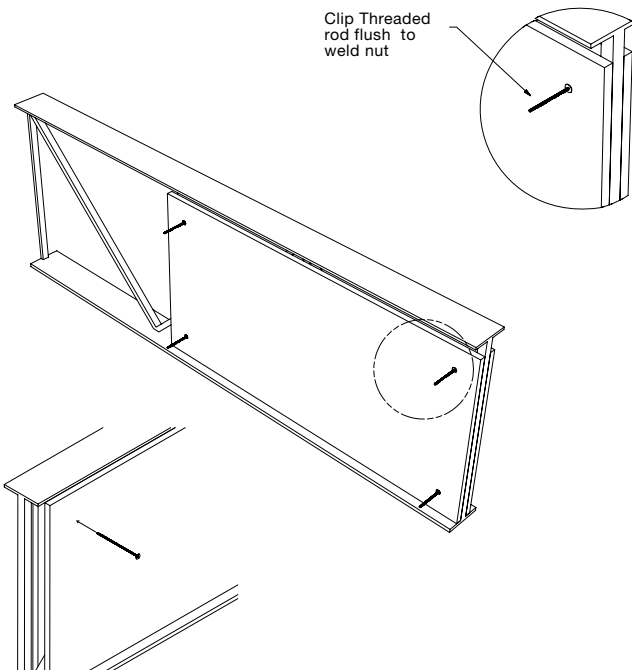

5. DIRECT-ATTACH – CEILING MOUNTING METHODS

Mounting Tectum® Direct-Attach panels to the ceiling follows the same fastener and mounting methods that are listed for walls in Section 4; however, the screw layout for any direct-attached ceiling panel should be mechanically fastened every 12" O.C. no matter what mounting method (A, D-20, C-20, or C-40). Metal or wood furring or Armstrong® Ceilings Drywall Grid should be installed perpendicular to panel direction no more than 24" O.C. Once furring or grid is installed, place panel on furring, making sure panel ends fall over furring strips or grid members.

Tectum panels must be installed in an ashlar pattern (staggered panel ends).

Mechanically attach panels every 12" O.C. to furring placing screw heads flush with the face of the Tectum panel. **Do not countersink screws.** Place the next panel against the furring, butting the end to the previously installed panel. Anytime a Tectum panel touches another Tectum panel, the end should be beveled. Mechanically fasten the second panel every 12" O.C.

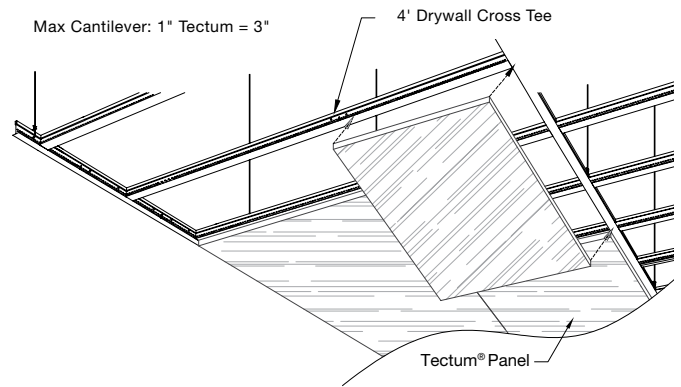

5.1 Direct-Attach to Armstrong® Ceilings Drywall Grid System

The requirements listed here represent the manufacturer's minimum acceptable installation recommendations, and may be subject to additional requirements established by the local authority having jurisdiction.

- All installations shall follow ASTM C636
- Suspension components should be tested per ASTM E3090 with duty ratings per ASTM C635

Use Armstrong® Ceilings Drywall Grid main beam (item HD8906) along with drywall grid cross tees (item XL8945) and (KAM 12) Angle Molding. The panel length should run parallel with the main runners and screw layout should be 12" O.C. as shown for direct-to-furring application.

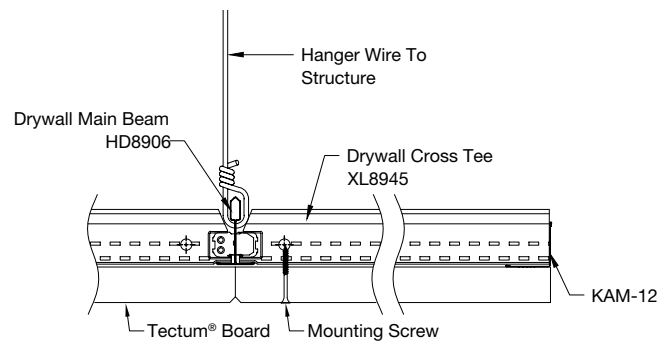

6. DISCONTINUOUS/FLOATING INSTALLATION

6.1 Clouds with Axiom® Trim

Due to slight surface-to-surface variation, Armstrong® Tectum® 1" thick Direct-Attach panels are not recommended in discontinuous/floating ceiling installation with trim. See our Lay-In and Tegular ceiling panels for discontinuous ceiling options using Prelude® XL® suspension system along with Axiom® Trim.

7. PANELS

7.1 Edge Detail/Interface

1" thick standard Tectum Direct-Attach panels are available in nominal sizes of 2'x 4', 2'x 8', and 4'x 8'. Actual width sizes are approximately 1/4" below nominal size (e.g.: 23-3/4" x 48"). On items 8180, 8181, and 8182, only the two long sides of the panel are beveled; however, the panels are field machinable. Items 8173, 8174, and 8175 are beveled on all four edges.

7.2 Cutting of Panels

Cut the panel using standard woodworking tools and techniques. A table saw is recommended for straight cuts and a band saw for curved cuts. In both cases, panels should be cut face up to minimize chipping of the face veneer. To replicate the 1/4" factory bevel, a hand router with a 1/4" bevel bit can be used. Fine-toothed blades recommended for finish cuts will yield the best results.

7.3 Directionality

Tectum panel items 8180, 8181, and 8182 are beveled on the two long edges. Items 8173, 8174, and 8175 are beveled on all four sides. Panels should be mounted beveled edge to beveled edge. In installation layouts where this is not possible, ashlar patterns (staggered end to end) are required.

7.4 Acoustic Infill for Direct-Attach Panels

Sound Absorption (NRC) of up to 0.85 can be achieved with 1" thick standard Tectum Direct-Attach panels. See Section 4, C-20 and C-40 mounting methods.

7.5 Field Painting

Field Painting Specification Recommendation:

Sherwin-Williams® Product: Waterborne Acrylic Dryfall (B42W1) 50 GAL. Drums MPI# 118 (or substitute Alkali-based, flat latex paints with similar properties)

*Tests have shown that six coats of spray-applied paint have no negative impact on the acoustical and fire properties of the Tectum panels.

Recommended Spread Rate per Coat

Wet Mils: 3.5 - 5.0

Dry Mils: 1.5 - 2.0

Coverage: 336-450 sq. ft./gallon approximate (based on flat surface)

** If necessary, cross spray at a right angle*

Surface Preparation

Surface must be clean, dry, and in sound condition. Remove all oil, dirt, grease, and other foreign material to ensure adequate adhesion.

Application Condition

Temperature: 50° F minimum, 110° F maximum (air, surface, and material); at least 5° F above dew point

Relative Humidity: 75% maximum

Dry Time: 20 minutes

Recoat: 1 hour *

During the early stages of drying, the coating is sensitive to rain, dew, high humidity, and moisture condensation. Plan painting schedules to avoid these influences during the first 16-24 hours of curing.

Dryfall characteristics will be adversely affected at temperatures below 77° F or above 50% relative humidity.

Application Equipment

The following is a guide. Changes in pressure and tip sizes may be needed for proper spray characteristics.

Airless Spray:

Pressure: 2800

Hose: 1/4" ID

Tip: 0.013"

Reduction: As needed up to 10% by volume.

Conventional Spray:

Gun: Binks 95

Fluid Nozzle: 63C

Air Nozzle: 63PB

Atomization Pressure: 60 psi

Fluid Pressure: 50 psi

Reduction: As needed up to 20% by volume

Brush and Roller: Not recommended

Field Touch Up and Color Match:

Standard White Color Match: Sherwin-Williams® #SW7005

Standard Natural Color Match: Sherwin-Williams #SW6126

* Tectum panels should be fastened in place prior to field painting.

8. SPECIAL INSTALLATION CONSIDERATIONS

8.1 Sloped

Sloped ceiling installations should follow standard ceiling installation with screws 12" O.C. per Section 5.

8.2 Pools/Natatoriums

1" thick standard Tectum panels are not intended for use in rooms with standing water. Contact TechLine 1 877 276 7876 for details on swimming pool options.

8.3 Exterior Installation

1" thick standard Tectum panels are not intended for use in exterior applications.

9. SEISMIC INSTALLATIONS

Seismic installations of Direct-Attach 1" thick Tectum panels are to be handled per building code.

MORE INFORMATION

For more information, or for an Armstrong Ceilings representative, call 1 877 276 7876.

For complete technical information, detail drawings, CAD design assistance, installation information, and many other technical services, call TechLine customer support at 1 877 276 7876 or FAX 1 800 572 8324.

For the latest product selection and specification data, visit armstrongceilings.com/tectum

Sherwin-Williams® is a registered trademark of The Sherwin-Williams Company; LLC; Fastenal® is a registered trademark of the Fastenal Company; Tapcon® is a registered trademark of ITW Brands; Inspiring Great Spaces® is a registered trademark of AFI Licensing LLC; All other trademarks used herein are the property of AWI Licensing LLC and/or its affiliates

© 2018 AWI Licensing LLC

BPLA-298661-1118

