

How to install your Mineral Fiber Planks using the Easy Up® Installation System or Adhesive

BEFORE YOU BEGIN:

- Mineral fiber planks should be handled with care, especially when removing them from the carton and during the installation process. The edges and face of the planks can damage easily.
- Store and install ceilings in areas with a temperature range of 60° to 85° F and not more than 70% relative humidity.
- Remove ceiling planks from cartons 24 hours before installation and allow to adjust to normal interior conditions of the installation area.
- Do not apply loose fill or batt insulation so that it rests directly on the back of the planks.
- Do not install ceiling tiles below embedded radiant-heat coils.
- Keep hands clean during tile installation to avoid fingerprints and smudges.
- Handle ceiling planks carefully to protect the face and edges from damage.
- Always cut ceiling tiles face up with a sharp utility knife.
- If you are installing on a sloped ceiling, the Easy Up® Installation System is intended for ceilings with a slope of less than 10 degrees. Planks should run horizontally across the plane of the ceiling. Planks should not run vertically, with the long edge running up the slope of the ceiling.
- For Adhesive Applications of mineral fiber only planks directly to existing drywall or plaster ceilings: Ceiling tile adhesive recommended, such as Henry 237 AcoustiGum™ Acoustical Ceiling Tile Adhesive. Please follow adhesive manufacturer's instructions for application and usage. Armstrong does not guarantee the performance of this or other adhesive products, either alone or in conjunction with Armstrong products.

SAFETY TIPS:

- Establish and maintain adequate ventilation in the work area. If high dust levels are anticipated during installation, such as with the use of power tools, take proper precautions.
- Wear long-sleeve, loose fitting clothing and gloves.
- Wear safety glasses to minimize the risk of eye injury.
- Use a sharp utility knife to ensure clean cuts. When not in use, store properly.

MAINTENANCE HINTS:

- Remove dust and loose dirt with a soft brush or vacuum hose with a soft brush attachment.
- Remove pencil marks, small smudges, or clinging dirt with an ordinary art-gum eraser.
- Clean with a damp sponge, mild soap and lukewarm water if necessary. Do not soak tiles with water.

TOOLS NEEDED TO INSTALL YOUR CEILING

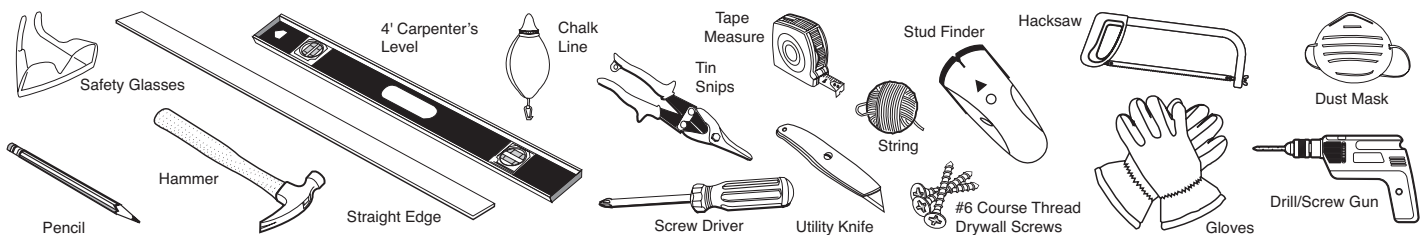

How to install your Mineral Fiber Planks using the Easy Up® Installation System or Adhesive

BEGIN INSTALLATION

Locate ceiling joists

To locate hidden joists, use either a stud finder or tap on the ceiling until you hear a solid thud. Mark the joist locations with chalk lines. Repeat this to locate other joists and determine their direction. Generally, joists are spaced 16" or 24" on center.

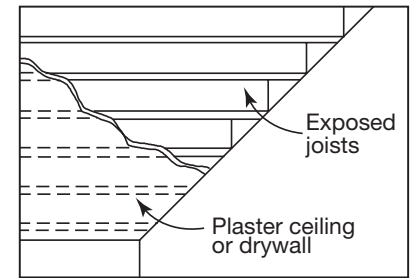

Determine border tile size for a balanced appearance

1. Measure room length in same direction as track
2. Divide by 6"
3. Multiply the remainder by 6"
4. Add 6" to the result
5. Divide result by 2
6. Record your border plank width

Example

Room = 170"
 $170" \div 6" = 28.333$
 $0.333 \times 6" = 2"$
 $2" + 6" = 8"$
 $8" \div 2 = 4"$
 Border plank width = 4"

Calculate your room

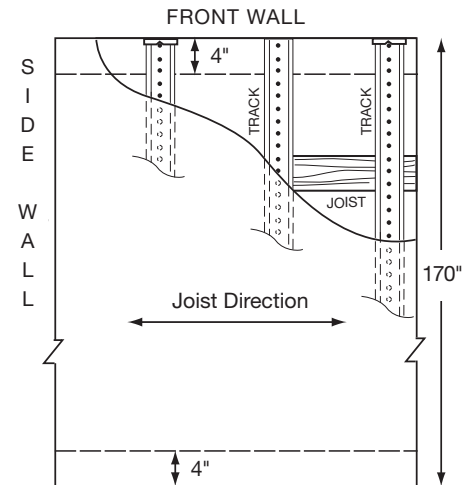

STEP 1

INSTALL TRACK

- Run Easy Up track in the opposite direction of the joists. Install track with #6 coarse thread screws. Screw length may vary, depending on your existing ceiling type. Over plaster – 3" screw; over drywall – 2" screw; direct to joists – 1 5/8" screw.

NOTE: *If necessary, you can shim Easy Up tracks to improve the flatness of your existing ceiling.*

- Screw first row of track 2" from the side wall. Use a screw at every joist. Continue installing first row of track end-to-end or overlapped side to side. **(illus. A)** Track should be installed flush to the front and back walls. To finish a row of track, cut to fit using tin snips or a hacksaw.
- Install remaining rows 12" on center. **(illus. B)**
- Install the last track row 2" from the opposite side wall. **(illus. C)**

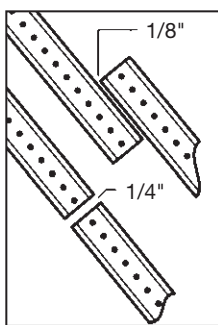

illus. A

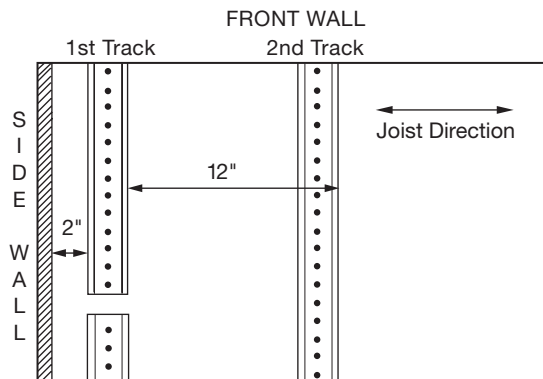

illus. B

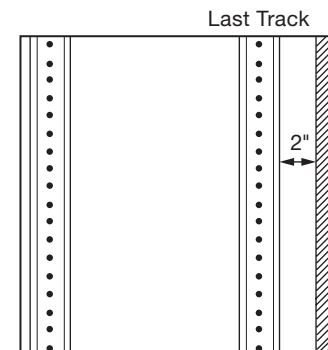

illus. C

How to install your Mineral Fiber Planks using the Easy Up® Installation System or Adhesive

STEP 2

INSTALL PLANKS

Snap a Chalk Line

- Add 1/2" to your border plank width and snap a chalk line across the tracks at that distance from front wall.

Cut First Row of Border Planks

- Familiarize yourself with the plank edges and face before you begin cutting your first plank. (illus. D)
- Trim first plank to the calculated border plank width, face up with a sharp utility knife. Do not cut off flange sides of plank.
- Cut off tongue on narrow edge of the first plank for a tight fit.
- Each plank for the first row will be cut to the border plank width.

Install First Row of Planks (illus. E)

- Snap a clip on every track with teeth facing away from the front wall.
- Push clips flush against the wall.
- Push first plank firmly into corner, thereby embedding clips into cut edge.
- Snap new clips on every other track and push them over the plank flange to secure the flange side of the plank.
- Lightly tap clips with hammer to seat plank tightly to front wall. Make sure the plank flange edge is aligned with chalk line.
- Complete first row of cut planks. Cut last plank to length that leaves a 1/2" gap at the opposite side wall. (illus. F on page 3)

Install Remaining Planks (illus. F)

- When starting the second row, cut some length from the first plank in order to stagger the seams. To maintain staggered seams from row to row, use various or different length sections to start the row to create a staggered pattern over several rows. Use the remaining piece of material cut from the last plank to start new rows for a random staggered pattern.
- Place a clip on every other track to secure the plank flanges. Clips must alternate tracks on every row and not be further than 24" apart.
- Snap a clip onto each track before inserting the last row of planks, and push flush with the end wall.
- Cut the last row of planks 1/2" short of the end wall. Measure and cut the face of the plank.
- Install end wall border planks and use a screwdriver next to the wall to embed the clip into the cut edge of the plank. (illus. G)

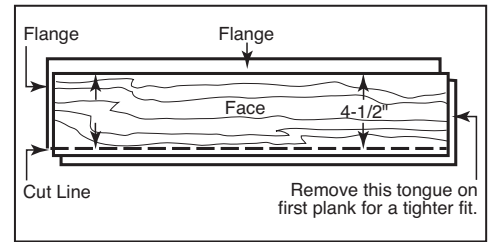

illus. D

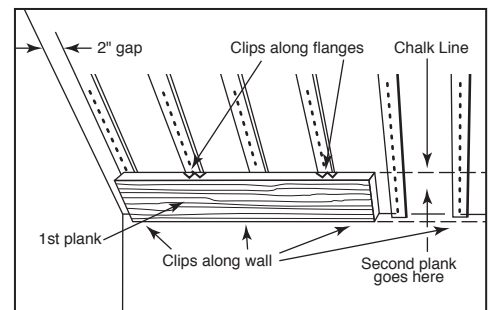

illus. E

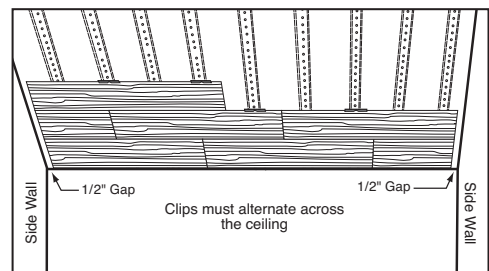

illus. F

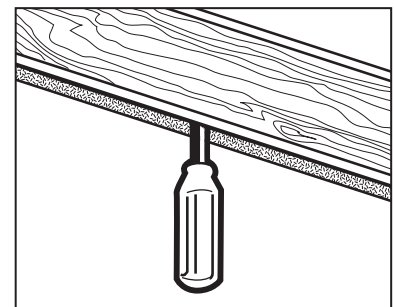

illus. G

How to install your Mineral Fiber Planks using the Easy Up® Installation System or Adhesive

STEP 3

INSTALL WALL MOLDING

- Paint or stain decorative molding before installing.
- Install molding at the joint between the ceiling and walls.
- Nail molding into the wall studs at least every 24". (**illus. H**)

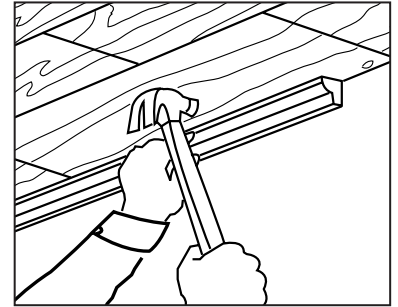

illus. H

NOTE: All Armstrong mineral fiber ceiling tiles can be painted with latex paint. The front and back of the tile should be painted. Armstrong cannot guarantee that the published surface-burning characteristics, fire-resistance ratings, acoustical performance, dimensional stability/sag, or light reflectance will remain the same after repainting. Field painting will void the warranty.

For additional information and on installing ceilings, including special installation tips, please visit our website at ceilings.com or call 1-877-ARMSTRONG (276-7876).6

Limited Warranty

For warranty information, please visit ceilings.com