

# WOODWORKS® Grille Tegular

## Assembly and Installation Instructions

### 1. GENERAL

#### 1.1 Product Description

WoodWorks® Grille Tegular ceiling panels consist of 24" x 24" and 24" x 48" wood panels with vertical wood blades which are deeper than they are wide. The vertical blade 24" x 24" and 24" x 48" panels should not be mixed during installation due to the different reveals. Vertical blade 24" x 24" panels are for checkerboard patterns and the vertical blade 24" x 48" panels are for linear applications only. The 24" x 24" panels install on Suprafine® 9/16" suspension systems while the 24" x 48" panels install on Prelude® 15/16" suspension system.

#### 1.2 Storage and Handling

All ceiling components should be stored in a dry interior location and remain in the original packaging before installation to avoid damage. The materials must be stored off the floor in a flat, level condition. Do not store in unconditioned spaces with humidity greater than 55% RH or lower than 25% RH, or with temperatures above 86°F or lower than 50°F. Use proper care when handling to avoid damage or soiling.

**CAUTION:** Use proper care and caution when handling suspension systems due to the sharp edges on all exposed clips.

#### 1.3 Site Conditions

WoodWorks Grille Tegular ceiling panels should be permitted to reach room temperature and have a stabilized moisture content for a minimum of 72 hours before installation. They should not be installed in spaces where the temperature or humidity conditions vary greatly from the temperatures and conditions that will be normal in the occupied space. These products cannot be used in exterior applications.

#### 1.4 HVAC Design and Operation Site Conditions

Proper design for both supply air and return air, maintenance of the HVAC filters, and building interior space are essential to minimize soiling. Before starting the HVAC system, make sure supply air is properly filtered and the building interior is free of construction dust.

#### 1.5 Temperature and Humidity During Installation

WoodWorks Grille Tegular panels are interior finish products designed for installation in temperature conditions between 50°F and 86°F, in spaces where the building is enclosed, and HVAC systems are functioning and will be in continuous operation. Relative humidity must not fall below 25% RH or exceed 55% RH. There must be proper ventilation of the plenum in high-moisture areas. All plastering, concrete, terrazzo, or any other wet work should be completely dry. All windows and doors should be in place. The heating, ventilation, and air-conditioning system should be installed and operable where necessary to maintain proper temperature and humidity conditions before, during, and after installation of the WoodWorks panels.

Real wood and wood composite products are natural building materials and will react to humidity changes; wood tends to contract with lower humidity and expand with higher humidity. Wood also tends to warp, twist, or bow, due to the natural stresses in the components and these humidity changes. Be aware of these natural tendencies when evaluating the products.

To ensure that the ceiling panels have stabilized to the current building conditions, the panels must be placed in an environmentally stable building location for a minimum of 72 hours prior to their installation.

#### 1.6 Material and Surface Finish

Blades and backers are constructed from solid poplar. Blades are stained and have a clear or semi-gloss coating. Backers are painted to have a black factory finish.

## 1.7 Color

WoodWorks® Grille Tegular panels are made of solid wood and are available in 15 finish options: Bleached Grey (GBG), Classic Grey (GCG), Carbon Grey (GCB), Antique Oak (GAO), Golden Maple (GGM), Natural Walnut (GWN), Warm Oak (GWO), Forest Walnut (GFW), Red Oak (GRK), English Chestnut (GEC), Rich Mahogany (GRY), Maple (GMP), Light Cherry (GLC), Dark Cherry (GDC), and White (GWH).

Natural variations in color and grain are characteristic of wood products. To maximize visual consistency, panels should be unpacked and examined collectively to determine the most desirable arrangement for installation.

## 1.8 Fire Performance

As with other architectural features located at the ceiling, WoodWorks Grille Tegular panels may obstruct or skew the planned fire sprinkler water distribution pattern, or possibly delay or accelerate the activation of the sprinkler or fire detection systems by channeling heat from a fire either toward or away from the device. Designers and installers are advised to consult a fire protection engineer, NFPA 13, and their local codes for guidance where automatic fire detection and suppression systems are present.

## 1.9 Plenum

WoodWorks Grille Tegular panels travel into the plenum for installation. Panels will require a minimum 6" clearance above the suspension system.

**NOTE:** Light fixtures and air handling systems require more space and will usually determine the minimum plenum height for the installation. It is required that MEP be independently supported. There must not be weight from any lights, diffusers, speakers, or similar devices supported by the aluminum panels or the suspension system.

## 1.10 Cleaning Recommendations

WoodWorks Grille Tegular panels can be cleaned with a soft, dry cloth.

# 2. WOODWORKS GRILLE TEGULAR PANELS AND ACCESSORIES

## 2.1 Panel Edges

The edges of the 24" x 24" grille tegular panels are created by the backer extending out past the blades of the panel, which support the panel on the grid flanges (*Fig 1*). The edges of the 24" x 48" grille tegular panels are created by the notched backers extending out past the blades with the notched portion of the backer resting on the grid flanges (*Fig 2*). The 24" x 48" panels are only supported by the 48" side while the 24" x 24" panel is supported on all four sides.

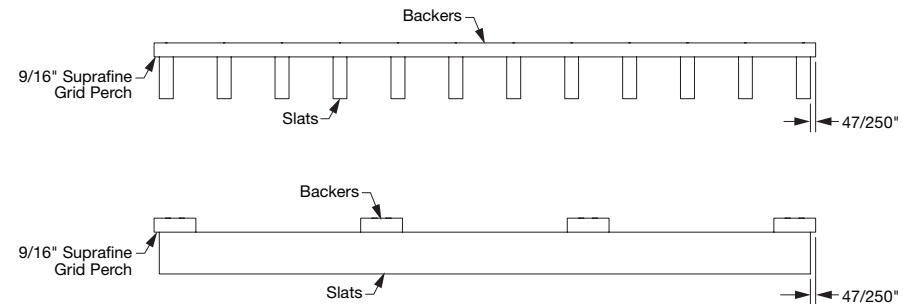

(Fig 1)

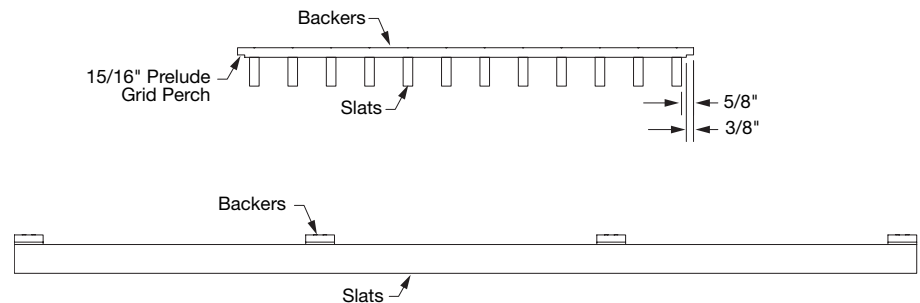

(Fig 2)

## 2.2 BioAcoustic™ Infill Panel

Use 24" x 24" black BioAcoustic™ infill panels (Item 5823) and 24" x 24" black Calla® panels to improve acoustical performance.

## 2.3 Finish Options for Cut Ends

- 5457GAL1\_\_ : Gallon size stain to finish cut ends
- 5457QT1\_\_ : Quart size stain to finish cut ends

## 2.4 Replacement Backers

- 7290N0L24GBL – WoodWorks® Tegular Backer – Square End
- 7290N2L24GBL – WoodWorks Tegular Backer – Notched End  
For use only on 24" x 48" Grille Tegular panels

## 3. INSTALLATION

### 3.1 General

The suspension system must be a standard 9/16" or 15/16" exposed tee grid. The suspension system, whether new or existing, must be properly installed and leveled using no less than 12-gauge galvanized steel wire. The suspension system must be leveled to within 1/4" over 120" and must be square to within 1/8" in a 48" x 48" module. Installation of suspension systems that do not meet this tolerance will produce unacceptable panel alignment. Suspension system installation must conform to ASTM C-636 and ASTM E-580 (CISCA seismic recommendations).

### 3.2 Load Capacity

Main beams must be capable of supporting the weight of the panels plus any additional ceiling components that are not independently supported from the building structure. The minimum acceptable load capacity for the main beam when supporting only ceiling panels is 11 lbs/LF, and the 48" cross tees must be capable of carrying a minimum of 5.5 lbs/LF. These weights are just within the lower limit for an intermediate-duty grid system. Job conditions may indicate the need to use a heavy-duty system or reduce the hanger wire spacing to increase the load-carrying capacity of the grid.

### 3.3 Suspension Grid

The panels install in a 24" x 24" or 24" x 48" module. The main beams must be spaced 48" O.C. The 48" cross tees must intersect the main beams at 90° every 24". The 24" cross tees must be installed at the midpoints of the 48" tees.

#### 3.3.1 Wall-to-Wall Perimeter (Fig 3)

Install wall molding along the perimeter at the established suspension system elevation. The face of the suspension system components rests directly on the wall molding (Item 7800).

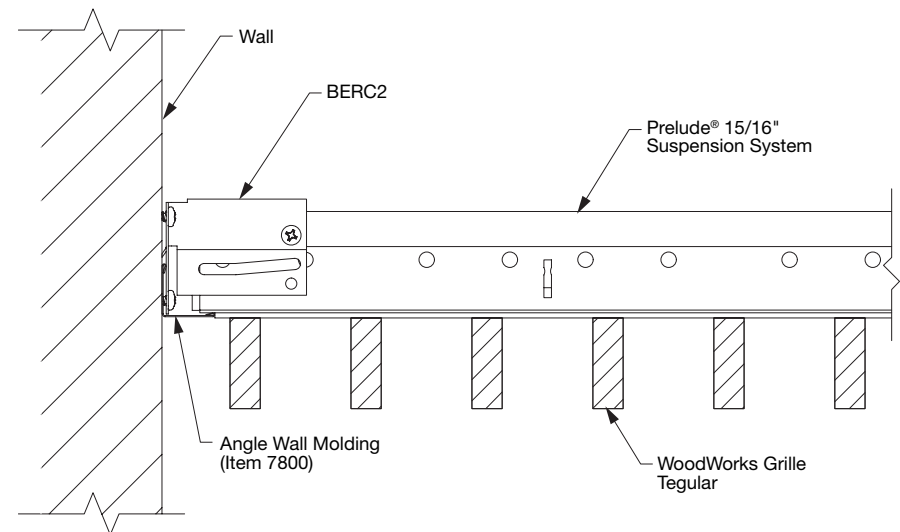

(Fig 3)

### 3.3.2 Floating Perimeter (Fig 4)

Axiom® trim inverted can be used for cloud installations with WoodWorks® Linear Tegular panels. The use of the adjustable trim clip, Item 7239, will fasten trim to the suspension system and allow for trim height adjustments as needed. For the best visual, it is recommended to have a black finish on the trim.

WoodWorks solid wood trims can also be used in cloud applications when paired with angle wall molding, Item 7800. Using a #8-1/2" pointed truss head screw (by others), fasten the angle molding (Item 7800) 1-7/16" from bottom of trim to create a flush visual between the panel face and the solid wood trim. The suspension system will then be fastened to the wood trim using the Item 5925 clips and additional screws, every 24" O.C. and overlapping the Item 7800 angle molding (Figs 5 & 6).

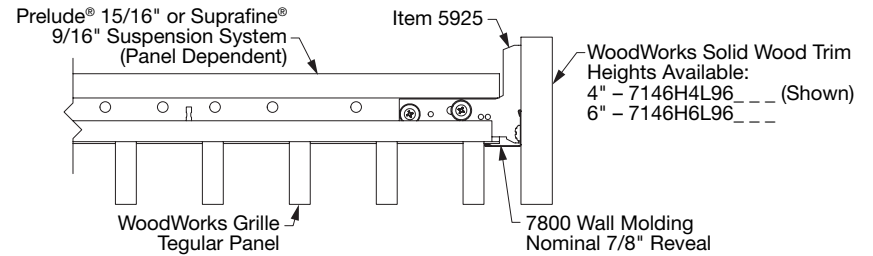

(Fig 5)

## 4. INSTALLATION

### 4.1 Cutting the Panel

Cut the panel using standard woodworking tools and techniques. A table saw is recommended for straight cuts and a band saw for curved cuts. Fine-toothed blades recommended for finish cuts will yield the best results.

A router can be used to cut a tegular edge on border panels, or a straight cutoff is possible. Refer to the ceiling plan for border panel size and spacing. Before cutting a border panel, remove the backer nearest to the edge and cut the blades and backer to fit the joint.

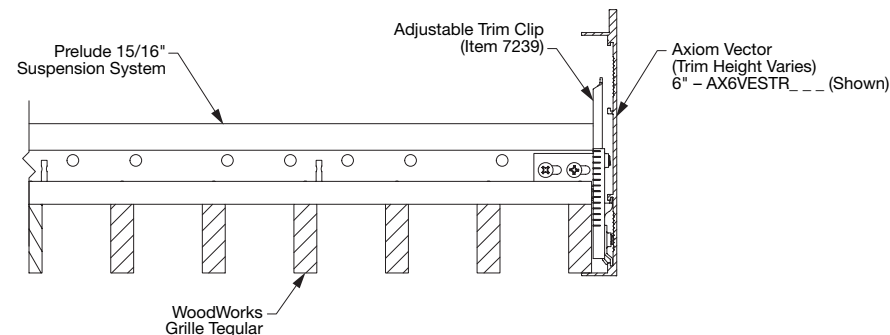

(Fig 4)

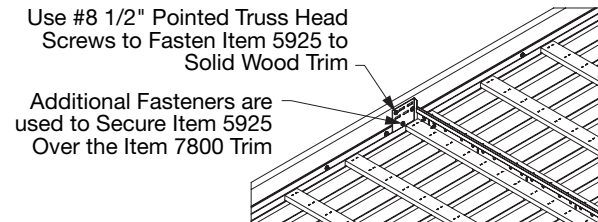

(Fig 6)

## 4.2 Cuts Perpendicular to the Blades

### 4.2.1 24" x 24" WoodWorks® Grille Tegular Panels (Figs 7-9)

Cuts perpendicular to the blades should be made by measuring the grid opening and cutting the planks to that dimension. Then the backer that was removed from the panel because of the cut needs to be re-attached to the back of the planks or replacement backers can be ordered separately if the factory backer cannot be re-used (Item 7290N0L24GBL). The backer needs to overhang the ends of the planks to create a tegular edge. The overhang for a 9/16" panel is 47/250".

### 4.2.2 2' x 4' Grille Tegular Panels (Figs 10-12)

Cuts perpendicular to the planks should be made by measuring the grid opening and cutting the blades to that dimension. The backer that was removed from the panel because of the cut needs to be re-attached to the back of the planks or replacement backers can be ordered separately if the factory backer cannot be re-used. The replacement backers must be the backer with the notched ends (Item 7290N2L24GBL), to be used with 24" x 48" Grille Tegular panels only. When re-attaching the factory backer or using a replacement backer, the backer will be flush with the blades on the 24" side and be centered to overhang 5/8" on the 48" side to create a tegular edge.

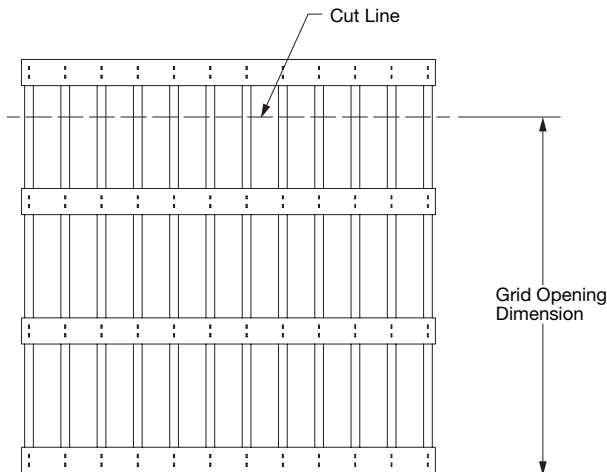

(Fig 7)

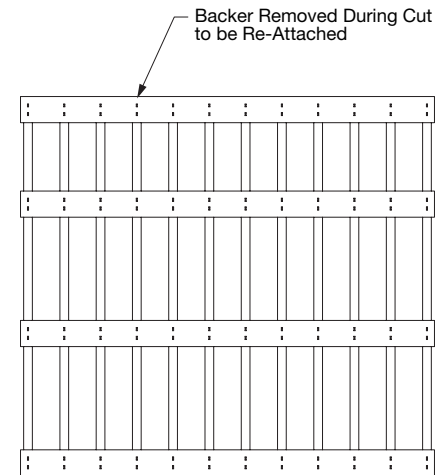

(Fig 8)

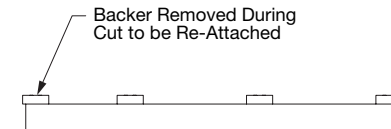

(Fig 9)

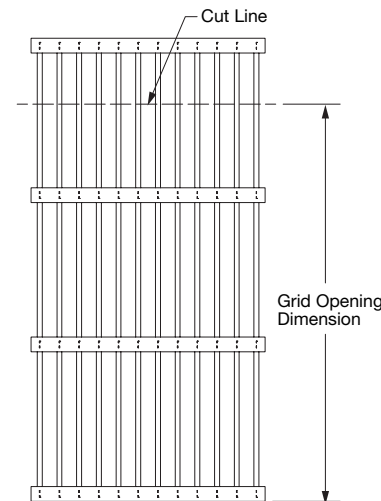

(Fig 10)

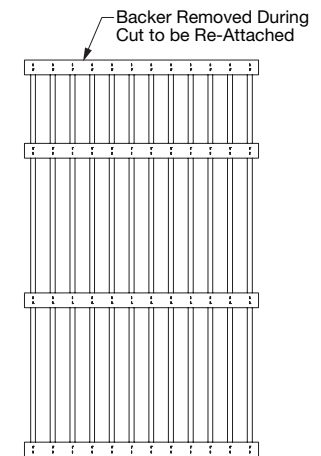

(Fig 11)

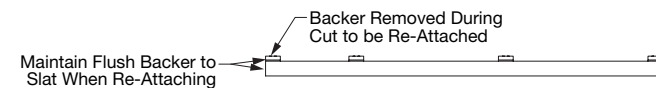

(Fig 12)

### 4.3 Cuts Parallel to the Blades

#### 4.3.1 24" x 24" Grille Tegular Panels (Figs 13-15)

Cuts parallel to the blades should be made by measuring the grid opening and then adding  $47/250$ " ( $9/16$ " panel) to that dimension. The cut should be made through all the backers and the added dimension will give you enough material to rest the backer on the grid flange. If this cut line falls on a blade, then the blade needs to be removed. The backer still needs to extend a minimum of  $47/250$ " ( $9/16$ " panel) passed the blade to create the tegular edge.

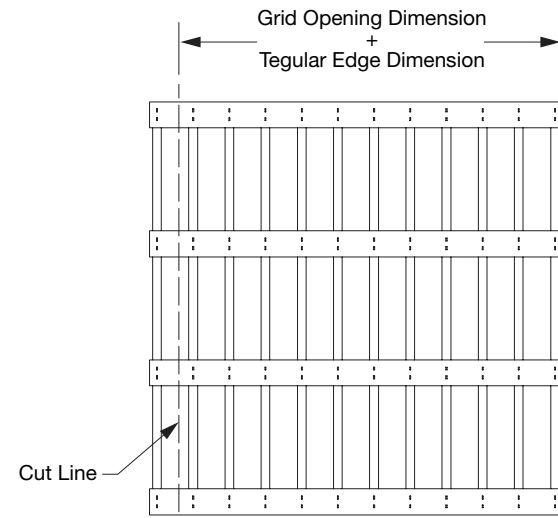

(Fig 13)

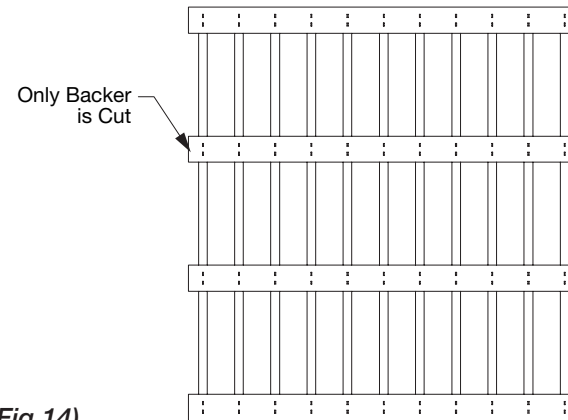

(Fig 14)

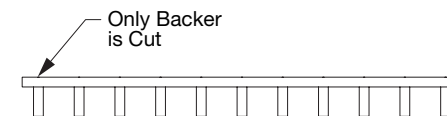

(Fig 15)

#### 4.3.2 24" x 48" WoodWorks® Grille Tegular Panels (Figs 15-18)

Cuts parallel to the blades should be made by measuring the grid opening and then adding 3/8" to the dimension before cutting. The cut should be made through all the backers and the added dimension will give you enough material to rest the backer on the grid flange on the 4' side of the panel. If this cut line falls on a blade, then the blade needs to be removed. **NOTE:** the notched end of the backer will be removed when panels are cut on the 4' side, however, the backer will need to extend a minimum of 3/8" (15/16" panel) past the blade to create the tegular edge.

**CAUTION: WOOD DUST.** Sawing, sanding, and machining wood products can produce dust. Airborne wood dust can cause respiratory, eye, and skin irritation. The International Agency for Research on Cancer (IARC) has classified wood dust as a nasal carcinogen in humans.

Precautionary measures: If power tools are used, they should be equipped with a dust collector. If high dust levels are encountered, use an appropriate NIOSH-designed dust mask. Avoid dust contact with eyes and skin.

First Aid measure in case of irritation: Flush eyes or skin with water for at least 15 minutes.

#### 4.4 Treating Exposed Edges

Cut panel edges that are exposed to view will have to be treated to look like factory edges. A matching stain should be used to touch up the exposed cut edge.

### 5. SEISMIC INSTALLATION

WoodWorks® Linear Tegular panel systems have been engineered and tested for application in all seismic areas based on these installation procedures.

**5.1** For more details on seismic installations please see our brochure: Seismic Design – What You Need to Know.

**5.2** All seismic installations of WoodWorks Linear Tegular panels must be installed per Seismic Design Categories D, E, and F. This is regardless of the total system weight. Heavy-duty Prelude® is required per ASTM E580.

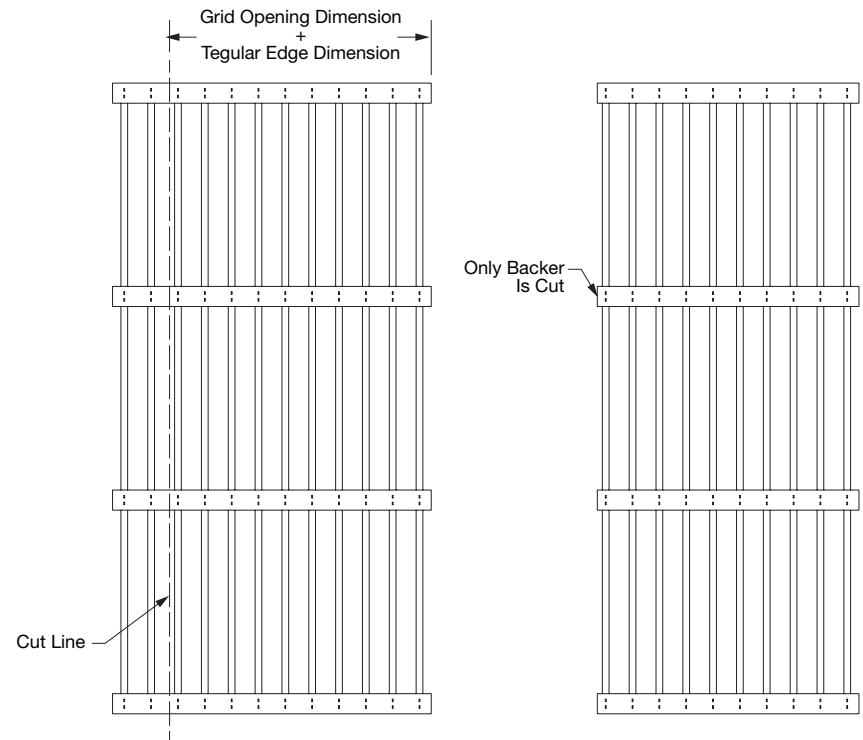

(Fig 16)

(Fig 17)

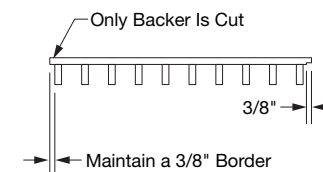

(Fig 18)

The installation must, in all cases, conform to the ASTM C636 requirements and the International Building Code. Installations may require independent engineering.

The requirements listed here represent the manufacturer's minimum acceptable installation recommendation and may be subject to additional requirements established by the local authority having jurisdiction.

### 5.3. Seismic Rx Category D, E and F

- Ceiling installation should conform to basic minimums established in ASTM C636
- Minimum 7/8" wall molding
- Suspension system must be attached on two adjacent walls
- Opposite walls require 3/4" clearance
- BERG2 maintains main beam and cross tee spacing; no other components required
- Heavy-duty systems as identified in ICC-ESR-1308
- Safety wires required on light fixtures
- Perimeter support wires within 8"
- Ceiling areas over 1,000 SF must have horizontal restraint wire or rigid bracing
- Ceiling areas over 2,500 SF must have seismic separation joints or full height partitions
- Ceilings without rigid bracing must have 2" oversized trim rings for sprinklers and other penetrations
- Changes in ceiling plane must have positive bracing
- Cable trays and electrical conduits must be independently supported and braced
- Suspended ceilings will be subject to special inspection
- Suspension layouts are the same as described in Section 4: Suspension System
- Connection to wall – See BPCS-4141 Seismic Design: What You Need to Know – Code Requirements Seismic Rx® Tested Solutions – SEISMIC RX® APPROACHES TO CATEGORY C, D, E, and F INSTALLATIONS
- Special bracing required – See BPCS-4141 Seismic Design: What You Need to Know – Code Requirements Seismic Rx Tested Solutions – Bracing and Restraint for Seismic Installations
- Seismic separation joints – See BPCS-4141 Seismic Design: What You Need to Know – Code Requirements Seismic Rx Tested Solutions – Seismic Separation Joints



Item No.	Description	Ordered Separately/Included With	Required for Install
<b>WOODWORKS® GRILLE TEGULAR PANELS</b>			
6723F51L2T9_ _ _	24" x 24" for 9/16" grid	Ordered Separately	Based on Design
6723F51L4T5_ _ _	24" x 48" for 15/16" grid	Ordered Separately	Based on Design
<b>SUSPENSION SYSTEM</b>			
7301	Prelude® XL® 12' HD Main Beam	Ordered Separately	Yes
XL7341	Prelude XL 4' Cross Tee	Ordered Separately	Yes
XL8320	Prelude XL 2' Cross Tee	Ordered Separately	Yes – For 24" x 24" Layouts
7891	12-gauge Hanger Wire	Ordered Separately	Yes
<b>PERIMETER TRIM</b>			
7800	Angle Wall Molding	Ordered Separately	Based on Design
AX_STR_ _ _	Axiom® Straight Trim – Recommended in Black	Ordered Separately	Based on Design
AX_VECUR_ _ _	Axiom Curved Trim – Recommended in Black	Ordered Separately	Based on Design
7146H4L96_ _ _	4" Solid Wood Trim – For Solid Wood Panels/Clips	Ordered Separately	Based on Design
7146H6L96_ _ _	6" Solid Wood Trim – For Solid Wood Panels/Clips	Ordered Separately	Based on Design
<b>ACCESSORIES</b>			
5457GAL1_ _ _	WoodWorks® Solid End-Stain (Gallon)	Ordered Separately	Based on Design
5457QT1_ _ _	WoodWorks Solid End-Stain (Quart)	Ordered Separately	Based on Design
7290N0L24GBL	Replacement Backers with Square End	Ordered Separately	Based on Design
7290N2L24GBL	Replacement Backers with Notched End	Ordered Separately	Based on Design
7239	Adjustable Trim Clip (ATC)	Ordered Separately	Based on Design
BERC2	2" Beam End Retaining Clip	Ordered Separately	Yes
<b>INFILL PANELS</b>			
5823	BioAcoustic™ Infill Panel – 24" x 24" in Black Matte Finish	Ordered Separately	Based on Design
2824BL	Calla® Square Lay-in Panel – 24" x 24" in Black Finish	Ordered Separately	Based on Design

## MORE INFORMATION

For more information, or for an Armstrong Ceilings representative, call 1 877 276-7876.

For complete technical information, detail drawings, CAD design assistance, installation information, and many other technical services, call TechLine customer support at 1 877 276-7876 or FAX 1 800 572-TECH.

All trademarks used herein are the property of AWI Licensing LLC and/or its affiliates.  
© 2023 AWI Licensing Company Printed in the United States of America

BPLA-297840-323

