

Armstrong Integrated Lighting for WoodWorks® Grille – Classics and WoodWorks® Grille – Forté

Assembly and Installation Instructions

This installation guide is a supplement to the standard WoodWorks® Grille – Classics & WoodWorks® Grille – Forté installation instructions.

TABLE OF CONTENTS

1. SOLUTION OVERVIEW

- 1.1 Storage and Handling
- 1.2 Site Conditions
- 1.3 Safety Recommendations

2. DESIGN & INSTALLATION CONSIDERATION

- 2.1 WoodWorks Grille Lighting Panel
- 2.2 Suspension System

3. GENERAL INSTALLATION & ASSEMBLY

- 3.1 Electrical Scope – Preparing the Plenum
- 3.2 Ceiling Contractor Scope – Installing Suspension System
- 3.3 Electrical Scope – Install Drivers
- 3.4 Ceiling Contractor Scope – Install WoodWorks Grille & Lighting Panels
- 3.5 Electrical Contractor Scope – Install Linear Lights
- 3.6 Ceiling Contractor Scope – Installing Access Door

1. SOLUTION OVERVIEW

The WoodWorks® Grille – Classics and WoodWorks® Grille – Forté integrated lighting panels are engineered with a factory-applied bracket designed to simplify field installation of linear lighting. These clips are strategically positioned to either replace a slat or sit between slats, providing a dedicated, secure mounting point for the approved linear light fixtures.

This integrated design protects the integrity of the system by eliminating the need for field modifications to the wood panels or the suspension system. The factory-installed clips are versatile, accommodating varying light lengths and widths to ensure a precise fit for the specified lighting.

The approved linear lights are designed to be field adjusted to the desired height and are available in three width options (3/4", 1-1/2", & 3-3/4"). This allows full compatibility with our Grille – Classics system, available in 8' panels, as well as our Grille – Forté system available in 4', 6', & 8' lengths, even when multiple panel sizes are combined. The system accommodates both continuous (10' or longer) and discontinuous lighting layouts offering design flexibility while maintaining a clean, uniform aesthetic.

The linear light fixtures are sold by Armstrong Integrated Lighting.

IMPORTANT NOTE: Installation requires collaboration between the ceiling contractor and the electrical contractor.

- Ceiling contractor: Installs the WoodWorks Grille – Classics or WoodWorks Grille – Forté system and lighting panels and performs minor grid adjustments as needed to accommodate drivers and access door.
- Electrical contractor: Installs the drivers, the linear light and completes wiring and power connections after the lighting panels are in place.

NOTE: Linear lights are supplied by their respective manufacturers. Coordinate product delivery and power requirements with the electrical contractor.

1.1 Storage and Handling

All ceiling components should be stored in a dry interior location and should remain in the original packaging prior to installation to avoid damage. The materials must be stored off the floor in a flat, level condition. Do not store in unconditioned spaces with humidity greater than 55% or lower than 25%, or with temperatures above 86°F or lower than 50°F. Use proper care when handling to avoid damage or soiling. WoodWorks Grille – Classics panels can be cleaned with a soft dry cloth.

Nesting panels during storage or handling is strictly prohibited, as it may result in damage to the panel light brackets.

1.2 Site Conditions

Building areas that will receive a ceiling must be free of construction dust and debris. Installation of the products must be carried out where the temperature is between 50°F and 86°F and relative humidity levels maintained between 25% RH and 55% RH. These temperature and humidity conditions must be met throughout the lifetime of the ceiling. Real wood and wood composite products are natural building materials and they will react to changes in humidity and temperature. (Wood tends to contract with lower humidity and expand with higher humidity.) Wood may also have a tendency to warp, twist, or bow due to the natural stresses in the components and these humidity changes.

Be aware of these natural tendencies when evaluating the products and suitability of this product in your space. It is also necessary for the area to be enclosed and for the HVAC systems to be functioning and in continuous operation. All wet work (plastering, concrete, etc.) must be complete and dry. These products cannot be used in exterior applications. To ensure that the ceiling panels have stabilized to the current building conditions, before their installation, Armstrong recommends uncrating and keeping panels on the skid, and placing panels in an environmentally stable building location for a minimum of 72 hours.

1.3 Safety Recommendations

All personnel must wear appropriate PPE, including, safety glasses, gloves, and footwear. Ensure all necessary tools needed for proper wiring of fixture to supply circuits is used.

Use a ladder, mobile scaffolding, or scissor lifts appropriate for the ceiling height and site conditions.

2. DESIGN & INSTALLATION CONSIDERATION

2.1 WoodWorks Grille Lighting Panel

System Compatibility: WoodWorks Grille lighting panels are designed as direct replacements for standard grille panels. They must be installed using the same suspension system and methods as the standard panels. For detailed suspension requirements, refer to the standard installation instructions for the specific WoodWorks Grille system being installed.

Visual Alignment: The factory-installed bracket on the Grille lighting panel features a tab that allows the height of the linear light to be fine-tuned in the field to be leveled to the desired height.

Maintenance and Accessibility: To ensure proper access for installation and future maintenance, an access door must be located adjacent to each light panel. This is achieved by using a torsion spring kit to convert a standard WoodWorks® Grille panel into an access point. Please refer to Section 3.4.1 for detailed instructions on creating and installing these access doors.

2.2 Suspension System

The suspension system shall be installed in accordance with the WoodWorks Grille – Classics or WoodWorks Grille – Forté installation instructions. Minor adjustments will be required when accessories are added to accommodate access door installation and/or when drivers are mounted directly to the suspension system.

3. GENERAL INSTALLATION & ASSEMBLY

Please read this entire document prior to beginning work to avoid any re-work. Refer to project-specific shop drawings for exact locations and layout of the linear light fixtures.

The ceiling contractor and electrical contractor must communicate clearly throughout the installation process to ensure a smooth installation process.

3.1 Electrical Scope — Preparing the Plenum

To be completed by a qualified electrician.

3.2 Ceiling Contractor Scope — Installing Suspension System

Performed by the ceiling contractor after electrician has completed prepping the plenum. The ceiling contractor is responsible for installing the suspension system to receive the WoodWorks Grille light panels in accordance with the applicable standard installation instructions.

3.2.1. Suspension System Modification

Minor modifications to the suspension system are required when drivers are supported directly by the grid, and additional accessories must be installed to accommodate access doors. All WoodWorks Grille light panels require an adjacent panel to be converted into an access door to allow proper access to the linear light fixture for future maintenance.

For WoodWorks Grille – Classics or WoodWorks Grille – Forté systems, minor reinforcement of the suspension grid is required at the cross tee locations where drivers will be installed. Reinforcement is achieved by installing XTAC clips at the affected cross tees (**Fig 1**).

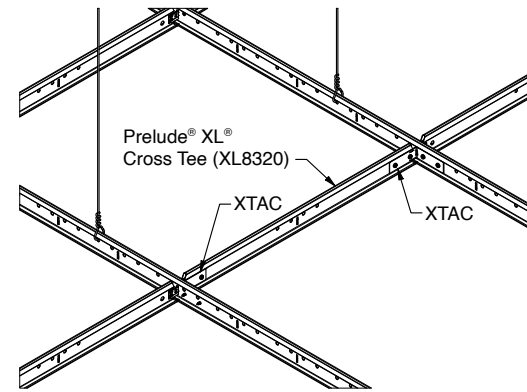

(Fig 1)

It is recommended that the access door locations be reviewed in advance, and that cross tees directly above access doors be avoided, as drivers will interfere with the torsion spring saddles used for the access doors.

The ceiling contractor shall reference the project-specific drawings to confirm the exact driver locations based on the light panel layout and reinforce the required number of cross tees accordingly.

NOTE: Installation of access door accessories occurs later in the installation process; refer to Section 3.4.1 for additional details.

3.3 Electrical Contractor Scope — Install Drivers

After all required modifications to the suspension system have been completed and the cross tees have been properly reinforced with XTAC clips, the electrical contractor shall install the drivers (**Fig 2**).

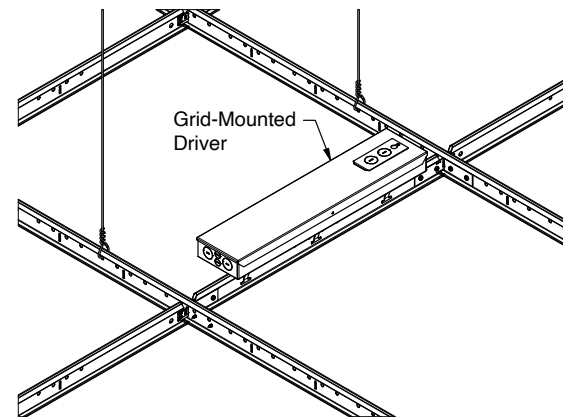

(Fig 2)

3.4 Ceiling Contractor Scope — Install WoodWorks Grille & Lighting Panels

The ceiling contractor shall install the WoodWorks® Grille panels along with their corresponding lighting panels. The panels arrive with the light bracket factory-installed and are installed using the same methods as standard grille panels in accordance with the installation instructions for the applicable ceiling system (**Figs 3 & 4**).

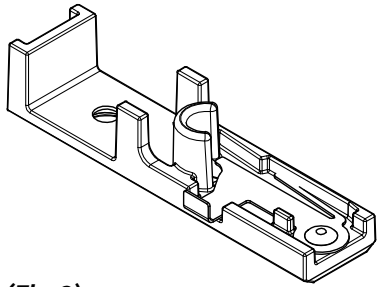

(Fig 3)

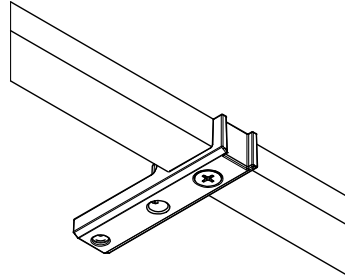

(Fig 4)

Once panels are installed the contractor must identify the panel adjacent to each lighting panel, as specified in the project drawings, to convert them into torsion spring access doors. Detailed procedures for this conversion are included in the standard system instructions and are further outlined in the steps below. Follow these steps precisely to ensure proper fit and accessibility.

3.4.1. Creating the Access Door

3.4.1.1 Required Tools & Accessories

Before beginning, ensure all necessary tools and components are available (**Fig 5**).

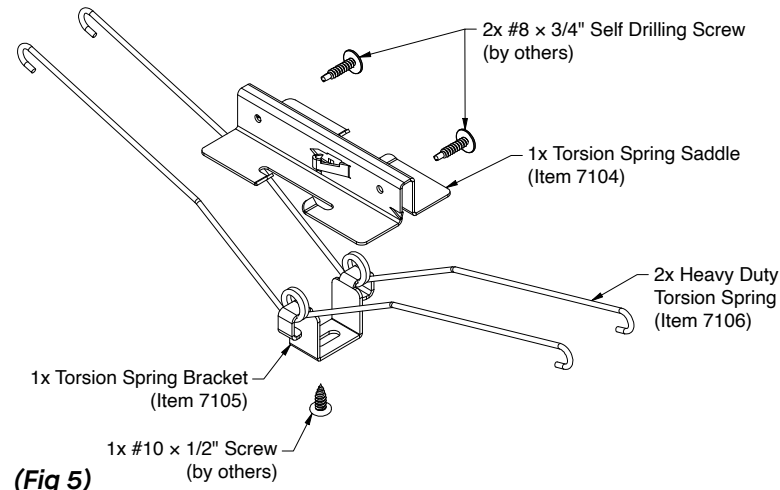

(Fig 5)

Refer to the table below for accessories and quantities needed per panel based on panel size being installed (**Fig 6**).

Accessories and Quantities Needed Per Panel Size

(All components to be ordered separately)

Panel Sizes	Torsion Spring Saddles (Item #7104)	Torsion Spring Bracket (Item #7105)	Torsion Springs (Item #7106)	#10 × 1/2" Wood Screw (By others) to fasten torsion spring bracket to backer	#8 × 3/4" Self-tapping Screw (By others) to fasten saddles to suspension system
1' × 4'	2	2	4	2	2
1' × 6'	3	3	6	3	3
1' × 8'	4	4	8	4	4

Other Tools Needed

A drill and a size 1/8" drill bit will be needed to pre-drill backers prior to fastening the spring bracket to backers. This will minimize splitting or damage to backers. Drill extender with a magnetic tip may be required depending on the depth of the blades.

(Fig 6)

3.4.1.2 Converting a Standard Grille Panel into an Access Door

Select the standard grille panel to be converted and remove it from the ceiling.

For the WoodWorks® Grille – Classics system, panels utilize a male-to-female construction. To remove a panel, first lower the female side several inches to create an angle, then slide the panel horizontally toward the lowered side. This motion disengages the male backers from the adjacent panel, allowing the panel to be safely removed from the opening (**Fig 7**).

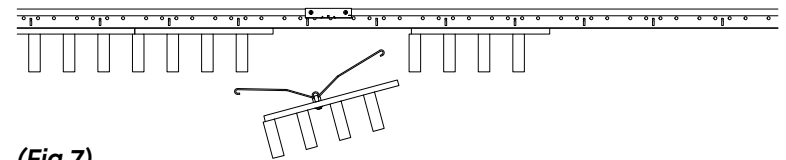

(Fig 7)

For the WoodWorks® Grille – Forté system, panel removal requires only unscrewing the panel. Since the backers are centered, the panel can be removed by lowering it straight down (**Fig 8**).

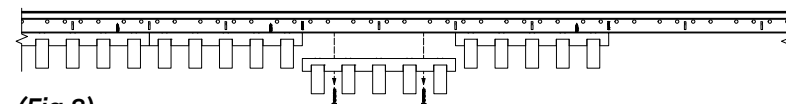

(Fig 8)

- Using the torsion spring bracket (Item 7105) and #10 × 1/2" screws, modify the panel according to the detail shown (Figs 9 – 12).

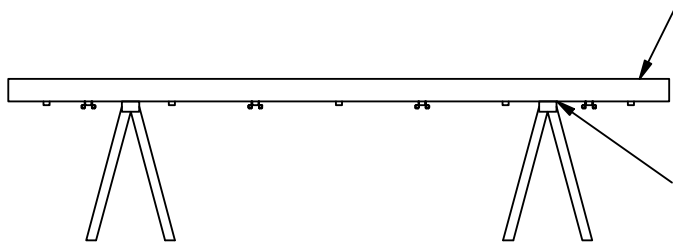

(Fig 9)

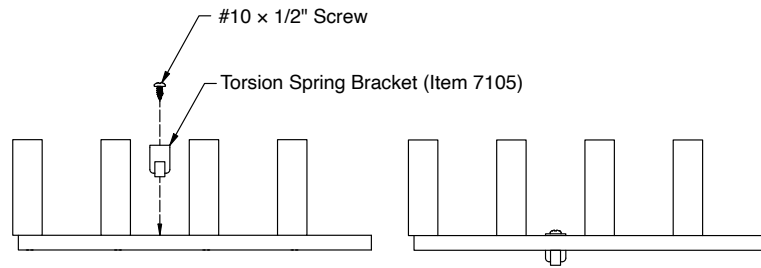

(Fig 10)

(Fig 11)

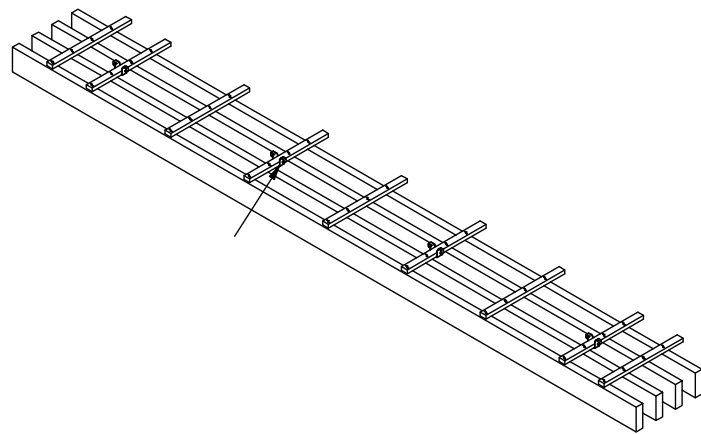

(Fig 12)

- On the hanging backers, position the brackets (Item 7105) based on the total number of slats in your panel as shown (Figs 13 & 14).

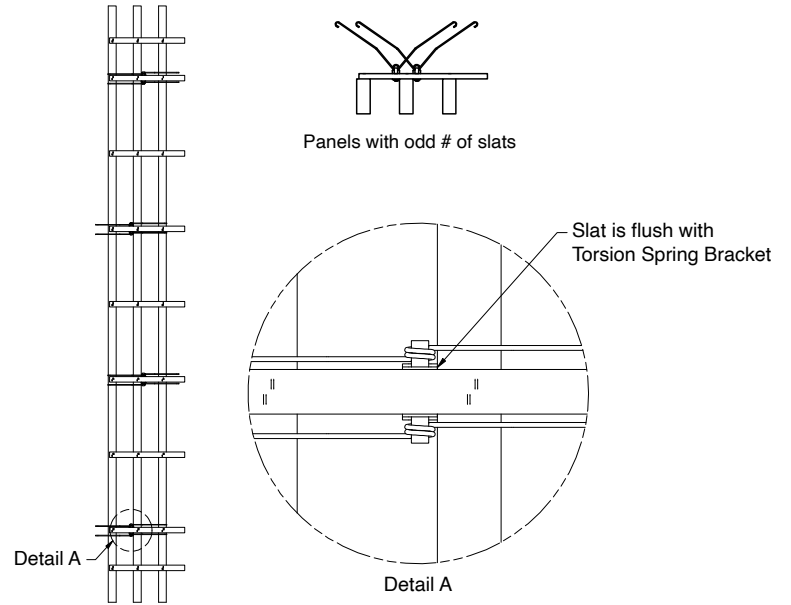

(Fig 13)

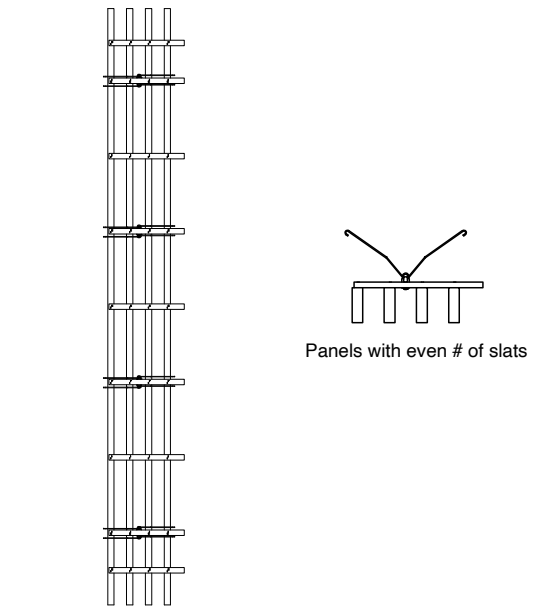

(Fig 14)

3.4.1.3 Install Torsion Spring Saddles to the Grid

Measure the exact bracket locations on the modified panel. Use these dimensions to position the saddles on the grid so they are perfectly aligned to receive the springs. Once the position is verified, secure each mounting saddle to the suspension system using a #8 × 3/4" self-tapping screw (By others) (Fig 15).

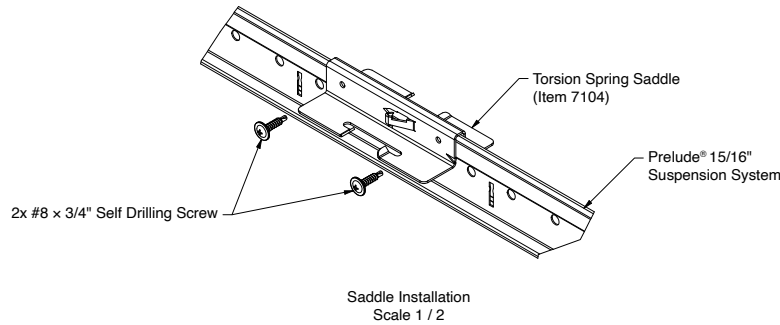

(Fig 15)

3.5 Electrical Contractor Scope — Install Linear Lights

A qualified electrician must perform all steps in this section.

- **Mount the Light:** Position the rod on the linear light and insert it through the designated hole on the light clip of the lighting panel (Figs 16-18).

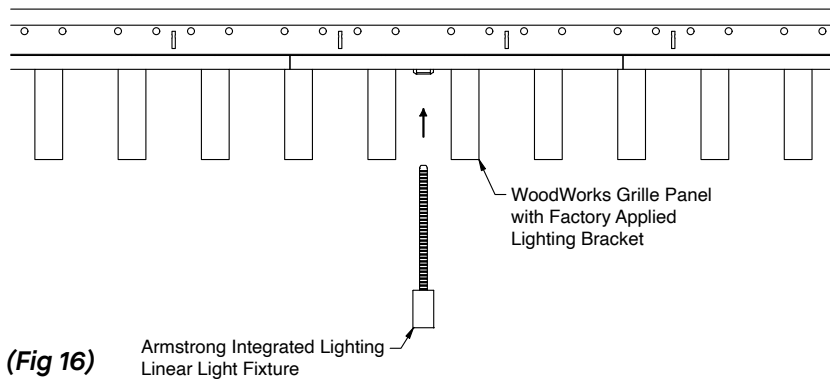

(Fig 16)

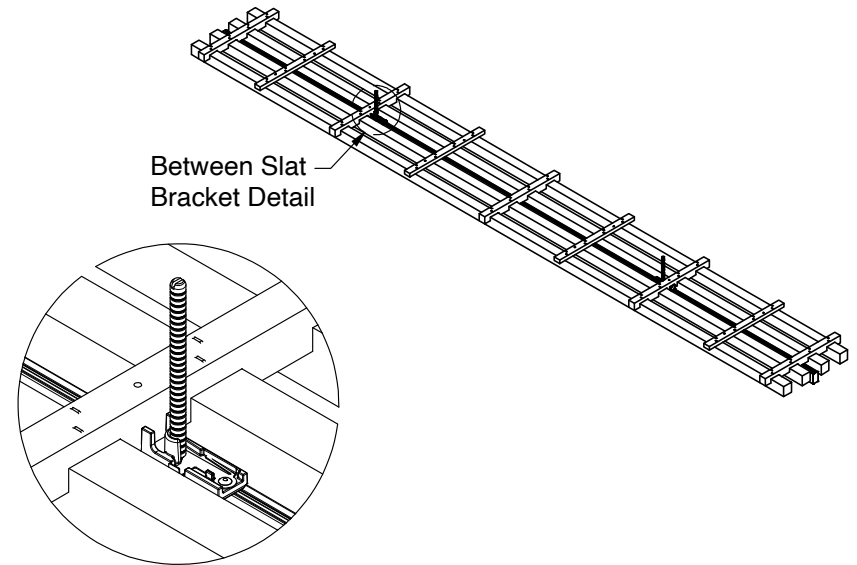

Between Slat Bracket Detail

(Fig 17)

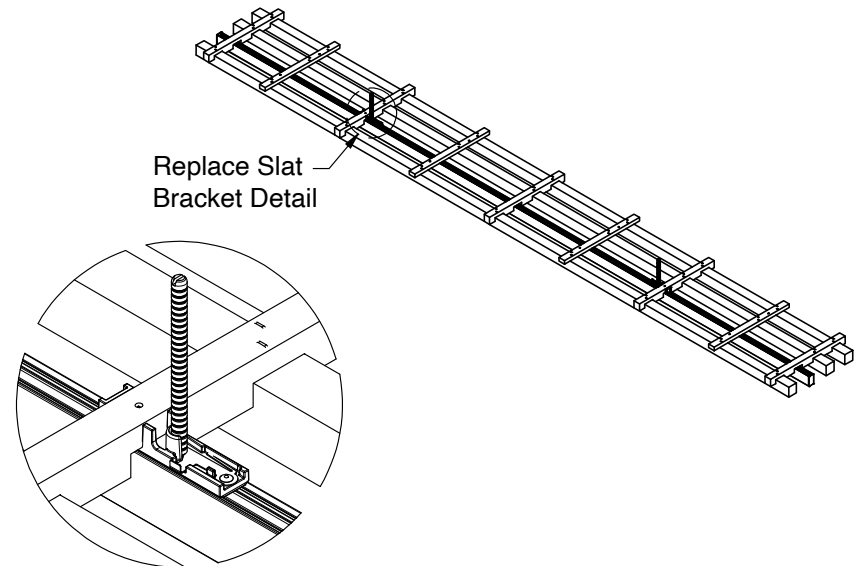

Replace Slat Bracket Detail

(Fig 18)

- **Adjust the Height:** Push the light upward and set it to the desired height, either leveling it as needed or aligning it flush with the bottom of the panel slats. The light can be adjusted as required by pressing the spring section of the light bracket. Refer to the linear light installation instructions for additional details on proper adjustment, where applicable.

- **Complete Wiring:** Once the light is at the correct height and all adjustments are finalized, complete the wiring of all light fixtures.

- **Attach Safety Cables:** Install safety cables on fixture as required by local code.

3.6 Ceiling Contractor Scope — Installing Access Door

Once all electrical work is completed, ceiling contractor completes the installation by installing the access door, following the steps below.

Step 1 — Add Torsion Springs to the panels as shown (Fig 19)

1. Align 2 springs with each bracket
2. Raise springs onto bracket arms

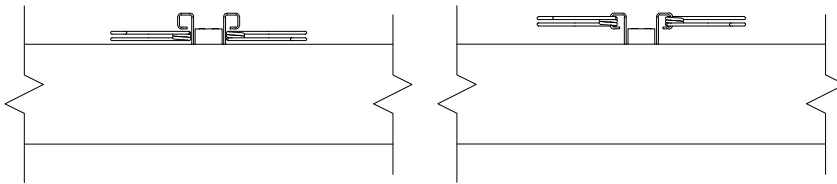

3. When ready to install panels, rotate springs up

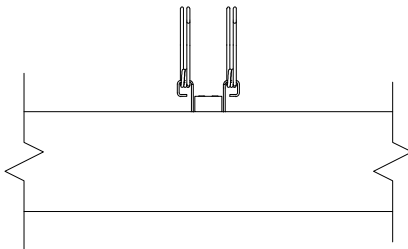

(Fig 19)

Step 2 — Install Door as shown

Align the spring with its corresponding slot on the saddle. Recommend doing this progressively across the panel can ease installation process.

For Grille – Classics, once all springs are engaged, tilt the panel to lead with the "male" side, sliding it horizontally to tuck the protruding backers behind the adjacent "female" panel (Fig 20).

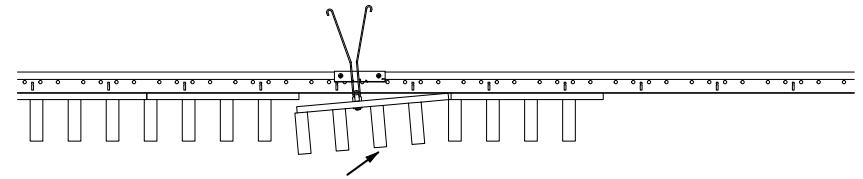

(Fig 20)

Once the joint is engaged, pivot the panel upward until level and push firmly to allow the torsion springs to pull the unit flush into its original position (Fig 21).

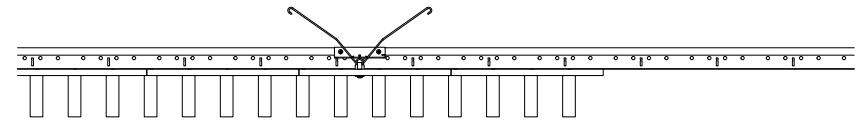

(Fig 21)

For Grille – Forté panels, simply align the spring with its corresponding slot on the saddle then push upwards on the panel, springs will spread and sit panel in place (Figs 22 & 23).

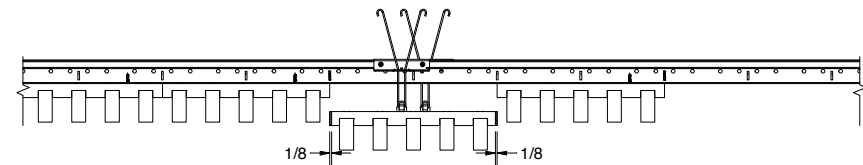

(Fig 22)

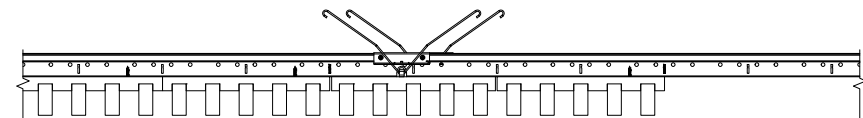

(Fig 23)

3.6.1. Access Door Removal for Future Maintenance

Carefully pull the panel down from the grid until the torsion springs are fully extended. Reach into the plenum and squeeze the spring legs to release them from the saddle, allowing the panel to be removed. Due to the panel weight, the product **IS NOT** designed to be left hanging in the swing-down position and should always be removed from the space for access.

Full Integration Installation Detail

(Fig 24)

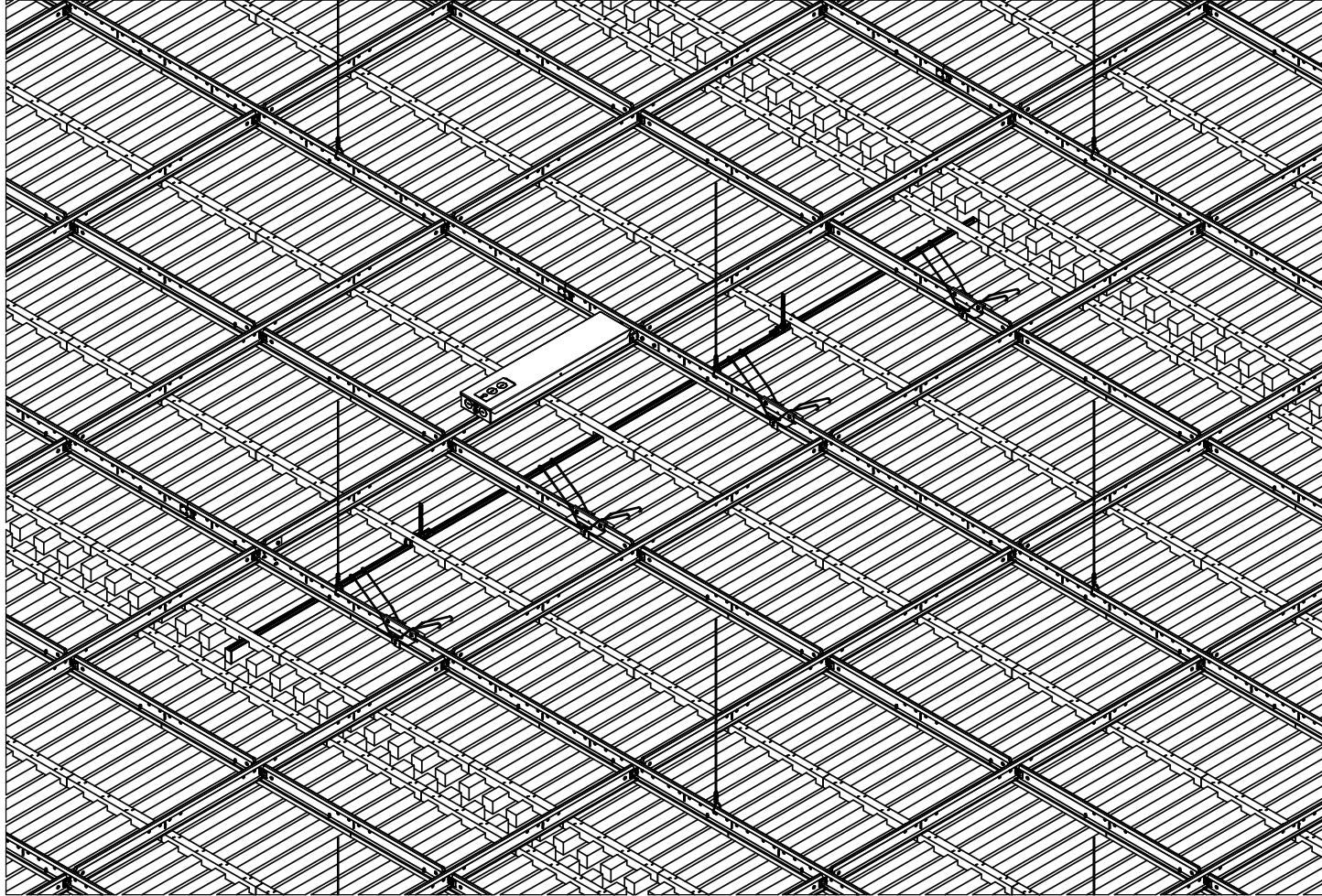

(Fig 24)

MORE INFORMATION

For more information, or for an Armstrong representative, call 1 877 276-7876.
For complete technical information, detail drawings, CAD design assistance, installation information, and many other technical services, call TechLine customer support at 1 877 276-7876 or FAX 1 800 572-TECH.

All trademarks used herein are the property of AWI Licensing LLC and/or its affiliates.
© 2026 AWI Licensing Company Printed in the United States of America

BPLA-293942-626



Armstrong[®]
World Industries