

MetalWorks™ Mesh

Assembly and Installation Instructions

1. GENERAL

1.1 Product Description

MetalWorks™ Mesh panels are manufactured from stainless steel wires or sheets that are welded, woven, or expanded. The panels are designed to be suspended from a Prelude® 360° Painted 15/16" suspension system or Prelude® XL® grid. For clean visual, black 360° grid with black painted plenum is recommended. Special consideration is needed regarding cutting the metal panels. Always wear cut-resistant gloves and eye protection when handling MetalWorks panels.

The edges of MetalWorks Mesh panels feature unique detailing. All edges are welded or prepared to minimize sharp edges. Use caution and wear appropriate hand and eye protection when installing metal panels. Depending on the type of panel, some installations should be accomplished with full sized panels. Improper cutting equipment could damage the panels or cause welds to fail. Refer to special cutting instructions in section 2.1. If a project requires special sizes, consult Architectural Specialties.

MetalWorks™ Mesh panels are produced with factory-applied powder coating available in White, Silver Grey, Gun Metal Grey, Tech Black, Copper, Bronze, Nickel Chrome, and a wide range of custom colors. Also, many panels can be finished with antique nickel plating. Consider coordinating grid colors for powder coated mesh panels, or black for the Antique Silver or Nickel Chrome. For acoustic solutions, acoustic infill panels can be installed above the panels. The best aesthetics can be achieved with black Calla®, School Zone® Fine Fissured™, and BioAcoustic Infill Panels. When combining mesh panels with acoustic panels, consider overall system weight for suspension system requirements. See specifics in section 4.

Panels are intended for interior use only.
For Seismic installations refer to section 9.

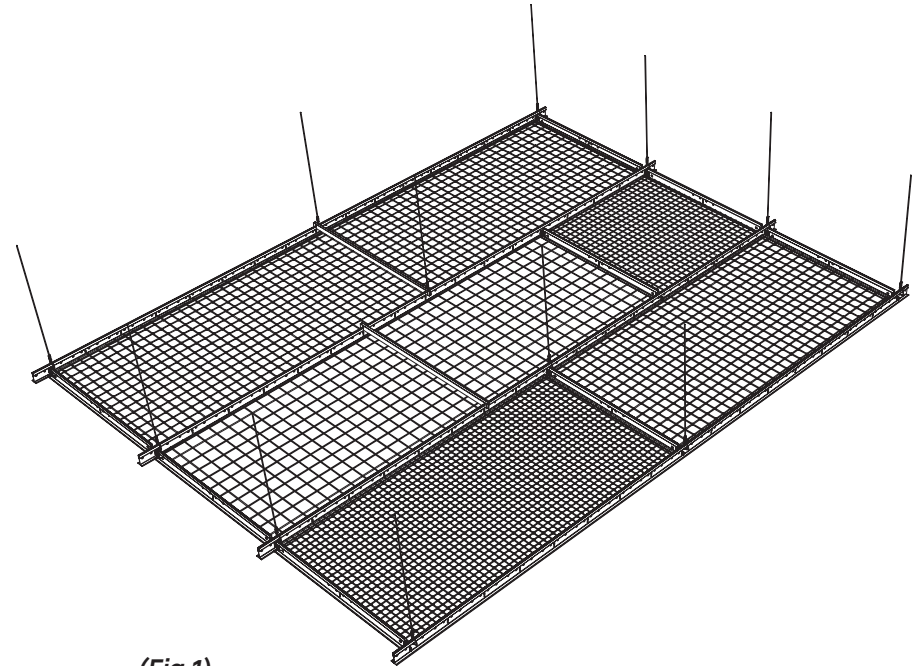

(Fig 1)

1.2 Storage and Handling

MetalWorks™ Mesh panels should be stored in a dry interior location and shall remain in their original crate prior to installation to avoid damage. Crate contains foam lining to protect tegular panel edges. Panels could potentially scratch one another, so keep back-to-back, and face-to-face for transporting. Keep in the protective packaging until installation. Proper care should be taken when handling the blades to avoid damage and soiling. For some patterns, it is likely that fingerprints will have to be wiped clean. See Cleaning section 1.10.

The 2' x 6' and 2' x 8' panels require two people for proper handling and installation.

1.3 Site Conditions

Areas to receive ceilings shall be free of construction dust and debris. Panels should only be installed in closed and acclimatized buildings. Such installations shall not be exposed to abnormal conditions, namely: chemical fumes, presence of standing water, or contact with moisture, as could result from condensations or building leaks. These products cannot be used in exterior applications.

1.4 Ceiling Layout

All MetalWorks Mesh panels are installed on 15/16" grid. To ensure desired aesthetic, layout your grid plan to center the suspension system.

1.5 Fire Performance and Sprinklers

MetalWorks Mesh panels have Class A fire performance based on E-84 testing. MetalWorks Mesh panels may obstruct or skew the existing or planned fire sprinkler water distribution pattern, or possibly delay the activation of the fire sprinkler or fire detection system. Designers and installers are advised to consult a fire protection engineer, NFPA 13, and their local codes for guidance on the proper installation techniques where fire detection or suppression systems are present. Refer to the Percent Open Area table on the data page to determine if you are able to install sprinklers above the mesh panel and confirm with code official. For the linear channel panel, there is a center-hole panel available with a 5" opening to allow penetrations. For other patterns, a hole may be cut through the panel to allow for sprinkler head and other penetrations.

1.6 Safety Considerations

Product arrives in a crate, make arrangements for safe handling. Edges of metal parts can be sharp. Handle metal carefully to avoid injury. Always wear safety glasses and gloves when working with metal.

Special consideration should be taken before field cutting panels. The linear channel pattern cannot be field cut. Please refer to section 2.1 for cutting instructions for each pattern. For those that can be cut, utilize recommended tools and metal-cutting blades in good condition. Improper cutting equipment could damage or dent the panels and cause welds to fail. If a project requires special size panels, consult Architectural Specialties.

The 2' x 6' and 2' x 8' panels require two people for proper handling and installation. These large panels also require the use of Stabilizer Bars to limit movement in grid. Extra safety and caution should be taken into consideration when installing these large panels.

1.7 Warranty

The MetalWorks Mesh system has been tested based on the installation method described in this document. Warranty will be voided if you do not follow instructions and guidelines.

1.8 HVAC Design & Operation and Temperature and Humidity Control

Proper design for both supply air and return air, maintenance of the HVAC filters and building interior space are essential to minimize soiling. Before starting the HVAC system, make sure supply air is properly filtered and the building interior is free of construction dust. Interior systems cannot be used where standing water is present or where moisture will come in direct contact with the ceiling.

1.9 HVAC Design & Operation and Temperature and Humidity Control

Installation of Mesh panels requires 3" of clearance above the suspension system to tilt and drop the panels into place.

NOTE: Light fixtures and air handling systems require more space and will usually determine the minimum plenum height for the installation.

1.10 Cleaning

An abrasive or strong chemical detergent should not be used. A mild detergent diluted in warm water, applied with a soft cloth, rinsed, and wiped off with a chamois will maintain the panels in good condition. Oily or stubborn stains, if not removed by washing, can be wiped with products like Fantastik®, but care is necessary to avoid affecting the gloss level of the paint or plated finish.

2. DESIGN CONSIDERATIONS

2.1 Panel Properties

See table.

Description	Item #	Panel Weight (per sq/ft)	Panel Orientation – Face	Panel Orientation – Direction	Supporting Sides	Cutting Recommendation
LAY-IN						
1Cell (woven)	6415	0.8 lbs	Same on both sides	Install so weave pattern in corners match (Wired over top or under bottom) (180-degree directional)	4	Cross wires – lineman's pliers, jig saw Perimeter rod – jig saw, circular saw, band saw
2Cell (woven)	6416	0.8 lbs				
Twin Round Narrow	6129	1.5 lbs	Wire frame UP Woven Wire rests on grid	Install so weave pattern in corners match (Wired over top or under bottom) (180-degree directional)	4	Cross wires – lineman's pliers, jig saw Wire Frame – jig saw, circular saw, band saw
Twin Flat Narrow	6412	1.2 lbs				
Twin Flat Wide	6410	1.2 lbs				
Single Flat Narrow	6411	3.3 lbs				
Single Mini	6413	1.3 lbs				
Single Narrow	6414	1.7 lbs				
Triple Narrow	6128	1.1 lbs				
1Diamond	6417	0.8 lbs				
2Diamond	6418	0.8 lbs				
1Cell (welded)	6131	1 lbs				
2Cell (welded)	6132	0.9 lbs				
3Cell (welded)	6133	0.4 lbs				
Lattice	6136	0.5 lbs	Wire frame UP Expanded metal rests on grid	Install so pattern runs in the same direction (directional panel)	4	Jig saw, offset handle snips, tin snips
Scallops	6137	0.7 lbs				
Trellis	6138	0.4 lbs	Rough side (tooling marks) UP Smooth side rests on grid			
Cascades	6139	0.5 lbs				
Quad Round Narrow	8198	1.2 lbs				
Single Flat Wide	8199	1.6 lbs	Face of angle iron perimeter lays flat against grid	(Non-directional)	4	Jig saw, lineman's pliers
Over-Under Square	8200	2.0 lbs				
Twin Circle	8202	1.9 lbs				
Round Rectangular	8201	1.1 lbs		Install so weave pattern in corners match (Wired over top or under bottom) (180-degree directional)	4	
Fine Rectangular	8203	1.8 lbs				
TEGULAR						
1Cell (welded)	8190	1.1 lbs	Rest frame on grid so the tegular edge drops below the grid	Install so wire underneath runs the same direction (180-degree directional)	2	Cross wires – lineman's pliers, jig sw Perimeter rod – jig saw, circular saw, band saw
2Cell (welded)	8191	0.8 lbs				
Lattice	8192	0.5 lbs	Rest frame on grid so the tegular edge drops below the grid	Install so pattern runs in the same direction (directional panel)	4	For expanded metal – jig saw, offset handle snips, tin snips For frame – tin snips, bullnose snips
Scallops	8193	0.6 lbs				
Trellis	8194	0.8 lbs				
Fine Rectangular	8195	1.9 lbs	Rest frame on grid so the tegular edge drops below the grid	Install so weave pattern in corners match (Wired over top or under bottom) (180-degree directional)	4	Jig saw, lineman's pliers
Linear Channel	8196	2.0 lbs	Rest wires on grid so the channels drop below the grid	Install so lines run in the same direction (180-degree directional)	2	Do not cut
Linear Channel with Center Hole	8197	1.8 lbs				

2.2 Sprinklers

See Fire Performance Section 1.5.

2.3 Approximate System Weight (lbs./Sq.Ft.) and Attachment to Deck. Please reference Table 2.1

Overall system weight will be based on the following factors:

- MetalWorks™ Mesh pattern, see the table in section 2: Design Considerations for lbs./Sq.Ft. weight of each pattern
- The weight of the suspension system weighs approximately 0.6lbs./Sq.Ft.
- If the panels are being installed in conjunction with acoustical infill panels then the weight of the acoustical infill panels must also be considered for total system weight.

Hanger connections to structure must follow the manufacturer's instructions and referenced code. Average system weight per square foot will depend on the three factors listed above.

2.4 Deflection

Minimal deflection is expected as panels increase in size (**Fig 2**). It is possible to see deflection up to 1/2" on the Welded and Woven patterns. Panels in the Expanded patterns may show additional deflection enhancing the industrial aesthetic.

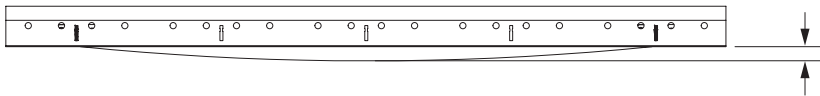

(Fig 2)

3. ACCESSORIES

3.1 General

Panels are protected in shipping to maintain shape. If, through handling, the panels deform slightly, use gentle pressure to flatten panel edge to ensure fit with grid flange. In cases where panels do not lay flat in the grid, hold down clips can be applied wherever necessary. Clear Hold Down Clips (CHDC) should be used with white grid, and 5600 Hold Down Clips (5600HDC) should be used with black grid. The Universal Hold Down Clip (FZUHDCA) can also be used (**Fig 3**). Hold down clips will reduce accessibility.



CHDC
Clear Hold Down Clip



UHDCA
Universal Hold Down Clip

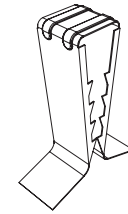

5600HDC
5600 Hold Down Clip

(Fig 3)

Alternatively, backfill with mineral fiber panels will help Mesh panels lay flat while maintaining accessibility, adding acoustics, and hiding the plenum and suspension system. The best aesthetics can be achieved with black Calla®, School Zone® Fine Fissured™, and BioAcoustic Infill Panels.

Stabilizer Bars (item 7425) are used on all installations for 2' x 6' and 2' x 8' panels to limit grid movement (**Fig 4**). May be visual if no backfill panels are used. Stabilizer Bars will reduce accessibility.

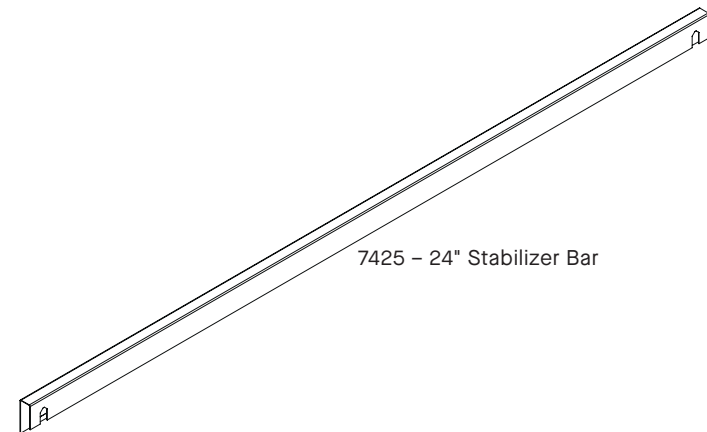

(Fig 4)

4. SUSPENSION SYSTEM (WALL-TO-WALL)

4.1 The requirements listed here represent the manufacturer's minimum acceptable installation requirements established by the local authority having jurisdiction.

- All installations should follow ASTM C636.
- All references to suspension component duty ratings are per ASTM C636.

4.2 System Components

MetalWorks Mesh can be installed on Intermediate-Duty or Heavy-Duty Prelude 15/16" suspension systems

Preferred Design Option:

- For installations without backfill panels where the web of the grid is visible use 360 degree Prelude suspension system in coordinating colors.
- For mesh colors without a coordinating suspension system color we recommend black 360 degree Prelude (730136BL) to hide the grid system with a black plenum.

4.3 Layouts

4.3.1 Standard 2' x 2'

Main beams installed at 48" OC, with 4' cross tees perpendicular to the main beams at 24" OC, and 2' cross tees spanning the midpoints of the 4' cross tees (Fig 5).

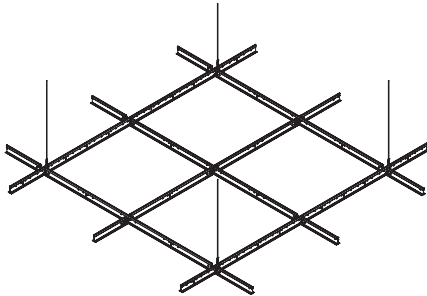

(Fig 5)

4.3.2 Standard 2' x 4'

Main beams spaced 48" O.C., with 4' cross tees perpendicular to the main beams at 24" O.C. (Fig 6).

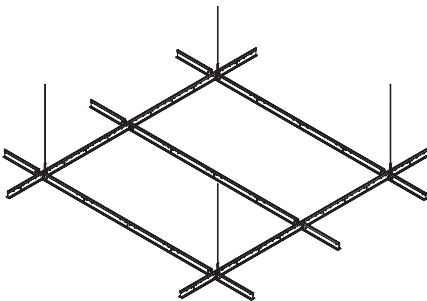

(Fig 6)

4.3.3 Standard 2' x 6'

Main beams spaced 48" O.C., with 4' cross tees perpendicular to the main beams at 72" O.C., and 6' cross tees spanning the midpoints of the 4' cross tees (Fig 7).

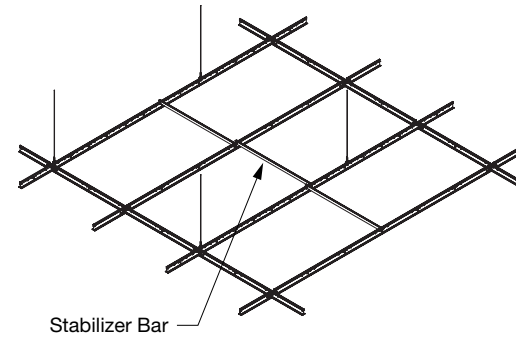

(Fig 7)

4.3.4 Layouts for 2' x 8'

Grid layouts for 2' x 8' panels can be constructed in three different ways. The end solution may be chosen based on the desired panel orientation in relation to the mains and load on the grid components:

1. Main beams spaced 96" O.C. with 8' cross tees perpendicular to the main beams at 24" O.C. (Fig 8). Supplemental wires are required at the midpoints of the 8' cross tees.

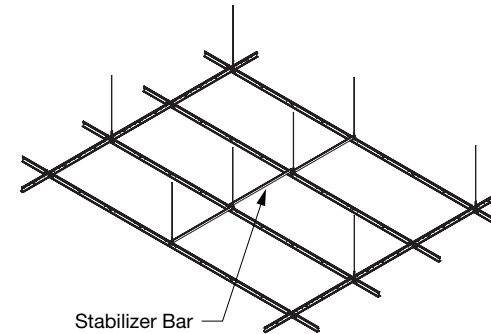

(Fig 8)

2. Main beams spaced 24" O.C. with 2' cross tees perpendicular to the main beams at 96" O.C. (Fig 9).

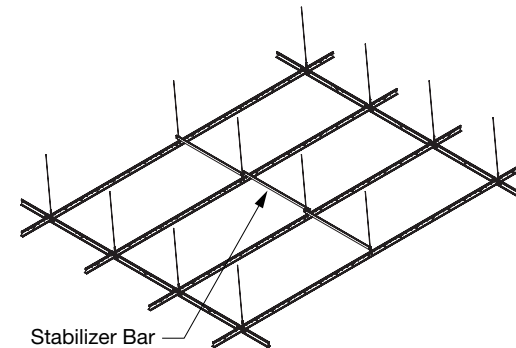

(Fig 9)

3. Main beams spaced 48" O.C., with 4' cross tees perpendicular to the main beams at 96" O.C., and 8' cross tees spanning the midpoints of the 4' cross tees (**Fig 10**). Supplemental wires are required at the midpoints of the 8' cross tees.

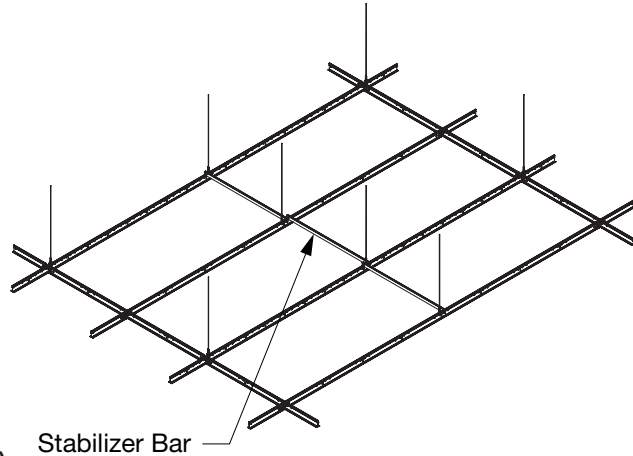

(Fig 10)

4.4 Wall to Wall Perimeter Options

Lay-in panels have no special requirements for wall molding installation and standard wall molding can be used.

Tegular panels drop 5/8" below the face of the grid. Raise the grid 5/8" above the desired finished ceiling height so that the panel face rests on the molding. **NOTE:** Linear Channel (8196 and 8197) drops 1/2" below the face of the grid (**Fig 11**).

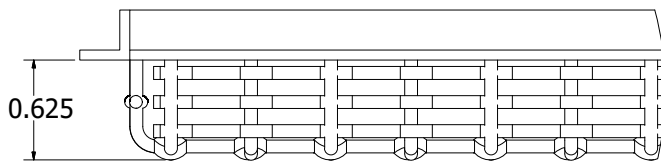

Edge Detail for Woven Tegular

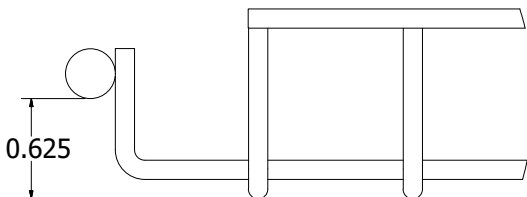

Edge Detail for Welded Tegular



Edge Detail for Linear Channel

(Fig 11)

Standard wall molding can be used and there is no need for perimeter hold down methods if the cutting recommendations are followed as the panels should lay flat. For directional panels that are supported on only two sides:

Items 8190 and 8191: because the directionality is caused by a subtle height difference in the overlapping wires, panels can be rotated at the borders to retain the two supporting sides.

Items 8196 and 8197: cannot be cut in the field. Installations should only utilize full-size panels. Cut borders can be filled in with mineral fiber or fiberglass panels. Black Calla® in square tegular (item 2822) or square lay-in (item 2820) is recommended. Other options for cut borders would be another mesh pattern that can be cut or a drywall border (seismic considerations).

5. FLOATING PERIMETER / TRIM FOR DISCONTINUOUS SYSTEMS

5.1 Floating Clouds

MetalWorks™ Mesh panels can be used in floating clouds with Armstrong's extruded aluminum trim options, however only full size panels are recommended.

Lay-in panels: standard AXTBC or FXTBC clips are used to connect the grid to the trim at the proper height.

Tegular panels: the Adjustable Trim Clip (Item 7239) is required to achieve the necessary grid offset (5/8" or 1/2") above the bottom flange of the trim.

NOTE: If necessary, AXSPHDC or FXSPHDC clips can be used to hold down mesh panels into the trim

6. PANEL

6.1. Edge Detail/Interface

MetalWorks Mesh panels install just like traditional acoustical ceiling panels. Lay-in panels are supported on the flange of the grid. The tegular panels are supported on the flange, with the face of the panel falling 5/8" or 1/2" below the grid face.

- Expanded panels have a c-channel, clamped edge for rigidity on all four sides. For best visual results, center panel within grid opening to hide the clamped edge.
- Welded tegular is a large perimeter bar on only 2 sides
- Linear Channel rests on the ends of the backer bars on all four sides
- Woven has angle-iron on all four sides or pattern extends to edge. For best visual results, center panel within grid opening to hide the angle-iron.
- Welded lay-in: the overall pattern extends to the very edge.

6.2 Installing MetalWorks Mesh with Acoustical Infill Panels

Lay the acoustic panel on the back surface of the mesh panel and install together or lay the infill panels on the back of already installed mesh panels as you progress across the space.

6.3 Cutting Mesh Panels*

Reference table 2.1.

NOTE: We do not recommend cutting the Linear Channel product; it is available with a factory cut 5" center-hole (item 8197) to allow for clearance of sprinkler heads, lights, or other MEP penetrations.

6.4 Directionality and color/finish considerations

Reference table 2.1.

6.5 The 2' x 6' and 2' x 8' panels require two people for proper handling and installation.

7. SEISMIC INSTALLATIONS (C AND D, E, F)

For more details on Seismic installations please see our BPCS-4141, Seismic Design: What You Need to Know brochure.

MetalWorks Mesh can be installed in seismic design categories C, and D, E, F. Due to the variable total system weight, outlined in section 2: Design Considerations the total system weight may exceed 2.5lb/ft².

Per ASTM E580 section 4.1.1, category C installations with an average weight over 2.5lb/ft² must be installed per category D, E, F requirements.

7.1 Seismic Rx Cat C

- Ceiling installation should conform to basic minimums established in ASTM C636.
- Minimum 7/8" wall molding
- Suspension system may be cut tight on two adjoining walls
- Minimum 3/8" clearance on two unattached walls
- BERC or BERC2 on all main beams and cross tees
- BERC2 maintains main beam and cross tee spacing; stabilizer bars not required
- Safety wires required on light fixtures
- Maximum ceiling weight of 2.5lb/ft²

7.2 Seismic Rx Cat D, E & F

- Ceiling installation should conform to basic minimums established in ASTM C636.
- Minimum 7/8" wall molding
- Suspension system must be attached on two adjacent walls – opposite walls require BERC2 with 3/4" clearance
- BERC2 maintains main beam and cross tee spacing; no other components required
- Heavy-duty systems as identified in ICC-ESR-1308
- Safety wires required on light fixtures
- Perimeter support wires within 8"
- Ceiling areas over 1,000 SF must have horizontal restraint wire or rigid bracing
- Ceiling areas over 2,500 SF must have seismic separation joints or full height partitions
- Ceilings without rigid bracing must have 2" oversized trim rings for sprinklers and other penetrations
- Changes in ceiling plane must have positive bracing
- Cable trays and electrical conduits must be independently supported and braced
- Suspended ceilings will be subject to special inspection

7.3 Suspension Layouts

Suspension layouts are the same as described in section 4:
Suspension System

7.3.1 Stabilizer Bars (item 7425) are used on all installations for 2' x 6' and 2' x 8' panels to limit grid movement. May be visual if no backfill panels are used. Stabilizer Bars will reduce accessibility.

7.4 Connection to wall

See BPCS-4141 *Seismic Design: What You Need to Know – Code Requirements Seismic Rx® Tested Solutions – Seismic Rx® Approaches To Category C & D, E, And F Installations.*

7.5 Special bracing required

See BPCS-4141 *Seismic Design: What You Need to Know – Code Requirements Seismic Rx® Tested Solutions – Bracing and Restraint for Seismic Installations.*

7.6 Seismic separation joints

See BPCS-4141 *Seismic Design: What You Need to Know – Code Requirements Seismic Rx® Tested Solutions – Seismic Separation Joints.*

MORE INFORMATION

For more information, or for an Armstrong Ceilings representative, call 877 276-7876.
For complete technical information, detail drawings, CAD design assistance, installation information, and many other technical services, call TechLine customer support at 877 276-7876 or FAX 800 572-TECH.

Fantastik® is a registered trademark of S. C. JOHNSON & SON, INC.; All other trademarks used herein are the property of AWI Licensing LLC and/or its affiliates.
© 2024 AWI Licensing Company Printed in the United States of America

BPLA-297075-924



Armstrong®
World Industries