

# MetalWorks™ Linear – Diverge™

## Assembly and Installation Instructions

### 1. GENERAL

#### 1.1 Product Description

MetalWorks™ Linear – Diverge™ is a metal ceiling system that utilizes linear planks that are available in 96" lengths and nominal 2", 4", 6", 9", 11", and 13" widths, as well as 1", 2", 3", and 4" depths, showcasing a 3/4" open reveal between the planks. The 3/4" open reveal can optionally be concealed with a filler strip. The Linear planks are made of 0.028" thick, 24-gauge electrogalvanized steel. Their postproduction, powder-coated finish is available in White, Silver Grey, Gun Metal Grey, Tech Black, Effects™ Wood Look finishes, and a wide range of custom colors and finishes. Perforated options with a plain border and acoustical fleece backing are available.

The Main Beam Carrier 2 (MBC2, Item 7277) used to suspend the planks is non-directional and has hanging features at 2-1/4" increments. All plank sizes can be installed on the same carrier system which allows for design and installation flexibility (**Fig 1**).

#### 1.2 Storage and Handling

The ceiling planks should be stored in a dry interior location and shall remain in cartons prior to installation to avoid damage. The cartons shall be stored in a flat, horizontal position. The planks should not be removed from the carton until the suspension system is installed. Proper care should be taken when handling the planks to avoid damage and soiling. It is recommended to hold the planks in the vertical orientation to avoid possibly bending the plank. White cotton or latex gloves are recommended for handling. It is recommended that two installers handle the 96" planks.

#### 1.3 Site Conditions

Areas to receive ceilings shall be free of construction dust and debris. MetalWorks Linear – Diverge planks should only be installed in closed and acclimatized buildings. This product is not intended for exterior purposes. Interior systems cannot be used where standing water is present or where moisture will come in direct contact with the ceiling.

METALWORKS™ LINEAR – DIVERGE™ WIDTHS	
Nominal Plank Width (Inches)	Module Width (Inches)
2"	2.25"
4"	4.50"
6"	6.75"
9"	9.00"
11"	11.25"
13"	13.50"

**NOTE:** Module width for each plank size will remain the same, regardless of plank depth or perforation

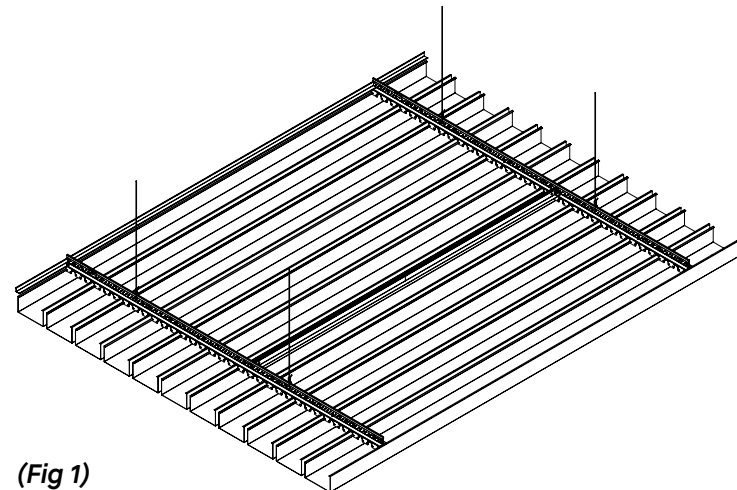

(Fig 1)

## 1.4 Fire Performance

MetalWorks™ Linear – Diverge™ planks may obstruct or skew the existing or planned fire sprinkler water distribution pattern, or possibly delay the activation of the fire sprinkler or fire detection system. Designers and installers are advised to consult a fire production engineer, NFPA 13, and their local code officials for guidance on the proper installation techniques where fire detection or suppression systems are present.

Cutouts in the center of the plank are created by first drilling or punching a hole near the center and then cutting in a spiral pattern to the finished size and shape. Exercise caution during this procedure as the hand will be near the cut edge of the plank. This procedure can be followed for cutting in can lights. Sprinkler cutouts can be made with a hole saw with appropriate metal blade. Standard 1" deep planks are recommended for use in can light or sprinkler locations.

## 1.5 Safety Considerations

This product arrives in a crate. Please plan for safe handling. MetalWorks Linear – Diverge planks require two people to install safely.

Edges of metal parts can be sharp. Handle metal carefully to avoid injury. Always wear safety glasses and cut-resistant gloves when handling or cutting metal.

When cutting planks, exposed raw edges of metal can be a safety hazard. The end cap is designed to give a finished edge appearance, however, deburring/sanding might be required based on the quality of the cut for proper fit. Cutting tools should be appropriate for steel. See specific cutting guidance in Section 5.0. Improper cutting equipment could damage or dent the metal planks.

## 1.6 Warranty

The MetalWorks Linear – Diverge system has been tested based on the installation method described in this document. Warranty will be voided if you do not follow these instructions and guidelines.

## 1.7 HVAC Design and Operation & Temperature and Humidity Control

Proper design for both supply air and return air, maintenance of the HVAC filters, and building interior space are essential to minimize soiling. Before starting the HVAC system, make sure supply air is properly filtered and the building interior is free of construction dust. Interior systems cannot be used where standing water is present or where moisture will come in direct contact with the ceiling.

## 1.8 Cleaning

An abrasive or strong chemical detergent should not be used. A mild detergent diluted in warm water, applied with a soft cloth, rinsed, and wiped off with a chamois will maintain the planks in good condition. Oily or stubborn stains, if not removed by washing, can be wiped with products like Fantastik®, but care is necessary to avoid affecting the gloss level of the paint finish.

## 2. DESIGN CONSIDERATIONS

### 2.1 Ceiling Plank Layout

**2.1.1** Planks in varying widths and depths can be installed in the same ceiling to create a striated visual.

**2.1.2** It is strongly encouraged to not cut the planks in the length direction, and to only install full-width planks. This includes at the perimeters of the installation.

**2.1.3** The ceiling plank layout should have perimeter planks equal in width on opposite sides. Divide the room dimension by the Main Beam Carrier 2 (MBC2) hook. Repeat dimension (2-1/4") to find how many hooks are available in the installation. The following chart shows how many hooks each plank needs in order to be installed:

Plank Size	No. of Hooks Needed
2" Plank	1
4" Plank	2
6" Plank	3
9" Plank	4
11" Plank	5
13" Plank	6

If there are multiple plank widths installed in the ceiling, add all the hooks needed together and divide that from the total number of hooks available to determine the number of pattern repeats that can be used. Divide the remainder by two to determine the width of the open borders.

**Example #1:** 11" nominal plank width; room dimension is 10' 4". Divide 10' 4" by 2.25 = 55 full hooks with about an 1/8" remainder. Divide 55 hooks by the 5 hooks needed for the 11" plank = 11 full-size 11" planks can be used. This will create the best visual and easiest installation.

**Example #2:** 9" nominal plank width; room dimension is 10' 4". Divide 10' 4" by 2.25 = 55 full hooks with about an 1/8" remainder. Divide 55 hooks by the 4 hooks needed for the 9" plank = 13 full-size 9" planks can be used with three hooks remaining. At this point, a 6" plank can be installed with the three remaining hooks, or the three remaining hooks can be divided by two to have one and a half hooks on each side of the room. This will create the best visual and easiest installation.

**Example #3:** Using multiple plank widths in a pattern of 2", 6", and 11"; room dimension is 10' 4". Divide 10' 4" by 2.25 = 55 full hooks with about an 1/8" remainder. Divide 55 hooks by the 9 total hooks needed for the 2", 6", and 11" plank pattern = 6 full pattern repeats can be used with one hook remaining. At this point, a 2" plank can be installed on the one remaining hook (**Fig 2**), or the hook can be divided by two to have half of a hook on each side of the room (**Fig 3**).

## 2.2 Plenum

Since MetalWorks™ Linear – Diverge™ planks are installed from below, they require minimal clearance above the suspension system. The planks do not need to travel into the plenum space during installation or removal.

**NOTE:** Light fixtures and air handling systems require more space and will usually determine the minimum plenum height for the installation.

## 2.3 Accessibility

See Section 6.0 for more information on how to create access areas.

## 2.4 Exterior Applications

It is not recommended to install any MetalWorks Linear – Diverge planks in an exterior application at this time.

## 2.5 Sloped Applications

It is not recommended to install any MetalWorks Linear – Diverge planks in a sloped application at this time.

## 2.6 Curved and Wall Installations

It is not recommended to install any MetalWorks Linear – Diverge planks in a curved or wall application at this time.

**2.7** For optimum visual design, backlighting planks is not recommended.

# 3. SUSPENSION SYSTEM INSTALLATION

## 3.1 Perimeter Molding

Install the Angle Molding (Item 7800) on the perimeter walls (**Fig 4**). Molding should be secured to the wall every 16 to 24 inches. The bottom flange of the Angle Molding will slide in between the two components of the Main Beam Carrier 2 (MBC2).

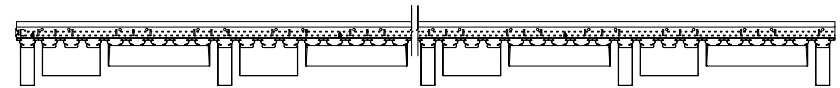

(Fig 2)

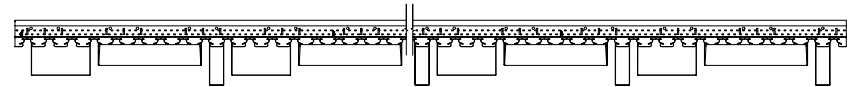

(Fig 3)

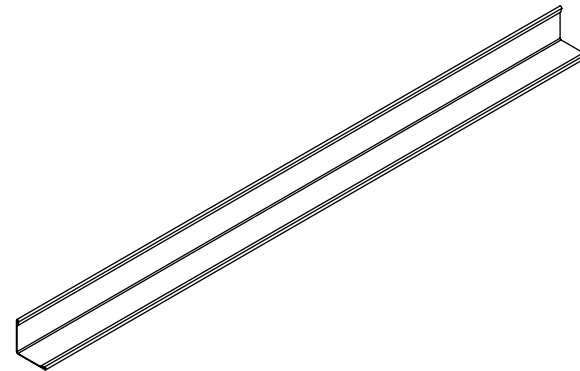

(Fig 4)

### 3.2 Hanger Wires

Secure hanger wires to the structure above to support the Main Beam Carrier 2 (MBC2). Wire spacing for MBC2s should be within 24" of the perimeter wall and then 48" O.C.

### 3.3 Main Beam Carrier 2 (MBC2)

**3.3.1** The MBC2s will be installed 48" O.C. perpendicular to the desired plank length direction. The first and last MBC2 must be installed within 24" of the perimeter wall (**Fig 5**). Every plank needs at least two connection points, so two MBC2s may be needed at the perimeters depending on the length of the planks.

**3.3.2** MBC2s are non-directional. MBC2s splice together with the SuperLock™ end detail just like standard drywall grid main beams.

#### 3.3.3 Main Beam Carrier 2 Installation

**3.3.3.1** MBC2s can be installed in one of two ways:

- 1) Alternating the splice locations row to row
- 2) Having all the splice locations line up

#### 3.3.3.2 Alternating Splice Locations Row to Row

**IMPORTANT NOTE:** MBC2s can only be cut at 72" for the hooks and rout holes to properly line up (**Fig 6**). Any other measurement could cause misalignment and unsatisfactory visuals or the inability to install the planks.

#### 3.3.3.3 Splice Locations Line Up

All MBC2s can butt up against the wall with a factory end and install full MBC2s until the opposite wall is reached (**Fig 7**). When cuts are needed, it is paramount to cut all carriers at the same location to ensure the hooks and rout holes will stay aligned.

### 3.4 Prebending Hanger Wires

Stretch a string line or set a laser at the bottom of the molding from one side to the other along a row of hanger wires. Bend the wires 7/8" above the string or laser (**Fig 8**).

### 3.5 Squaring and Cutting the Main Beam Carrier 2

**3.5.1** Stretch a string line or set a laser from one side of the room to the other at the bottom of the molding (string/laser perpendicular to the carrier). The line should be out from the "end" wall by the calculated width of the open border reveal. Refer to Section 2.1.3 for width of border reveal. Make sure the first full hook is at least 1/2" out from the wall to ensure there is enough room to install the plank.

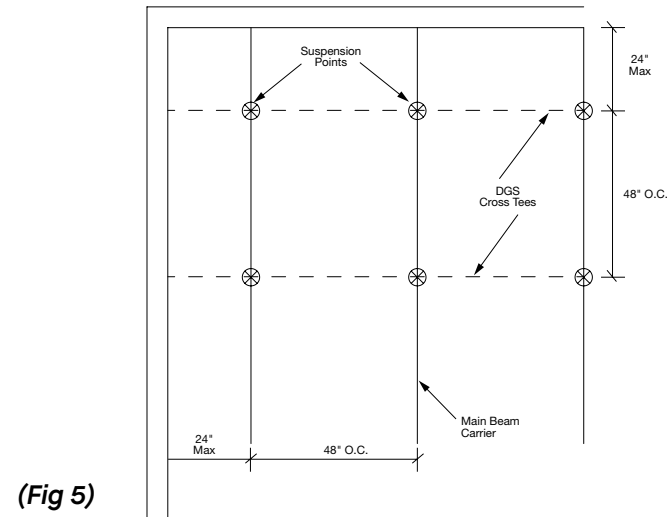

(Fig 5)

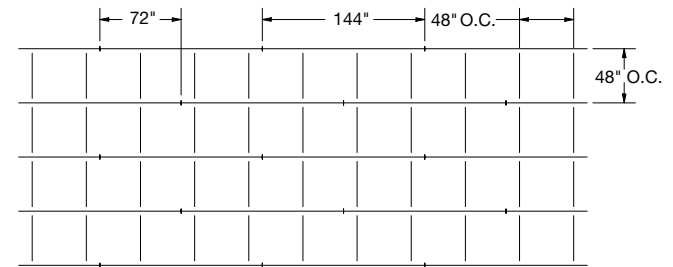

(Fig 6)

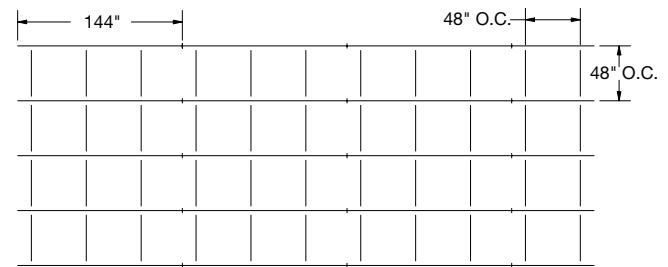

(Fig 7)

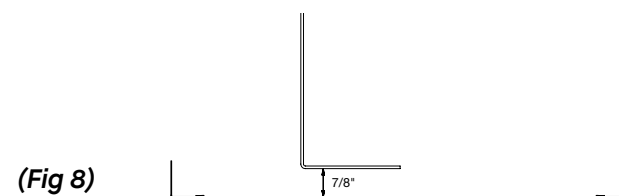

(Fig 8)

**3.5.2** Measure from this line to the wall. Cut the first MBC2 in each row so the desired notch lines up with the line (**Fig 9**). Add a sharp point screw in second hole from the end on the underside of the carrier if you cut the factory screw off (**Fig 10**).

**IMPORTANT NOTE:** Make sure each MBC2 is cut at the same exact location to ensure that the hooks and rout holes will stay aligned. Any other measurement could cause misalignment and unsatisfactory visuals or the inability to install the planks. Check the carrier's alignment by lining up the laser and the same hook on each carrier.

**3.5.3** The suspension system must be leveled to within 1/4" in 10' and must be square to within 1/16" within each 4' x 4' grid module. Installation on suspension systems that do not meet this tolerance will produce unacceptable plank alignment.

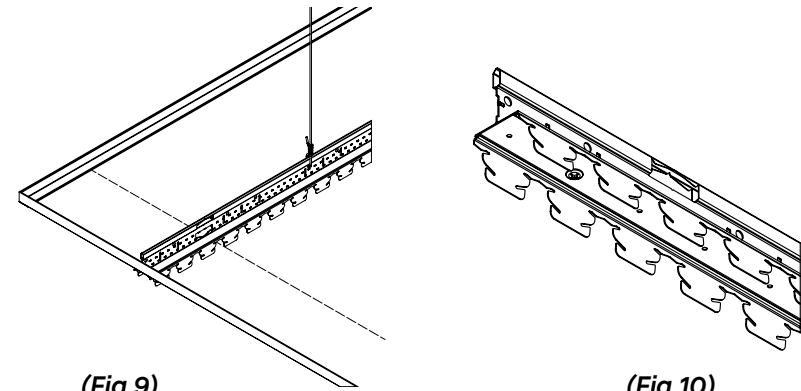

### 3.6 Main Beam Carrier 2 Attachment

**3.6.1** The bottom flange of the Angle Molding will slide in between the two components of the MBC2. Once each carrier is aligned with the guide string explained in Section 3.5, fasten them to the perimeter molding with a framing screw or a pop rivet (**Fig 11**).

**3.6.2 NOTE:** Make sure to leave a full hook at the beginning of the MBC2 to accept the perimeter plank (**Fig 11**). Make sure the first full hook is at least 1/2" out from the wall to ensure there is enough room to install the plank.

**3.6.3** Complete the run of carriers to the other end of the installation space.

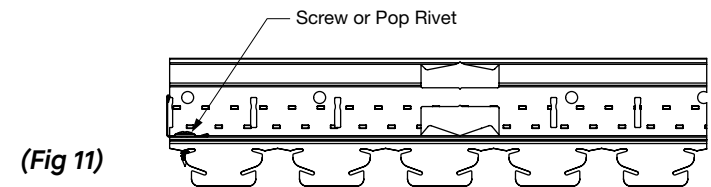

### 3.7 Drywall Cross Tees

The first row of 4' drywall cross tees (XL8945) should be within 24" of the perimeter wall and then 48" O.C., creating 4' x 4' grid modules.

## 4. DIVERGE PLANK INSTALLATION

### 4.1 Plank Installation

**4.1.1** Refer to Section 2.1 for help on how to layout the plank system.

**4.1.2** Install a row of planks by inserting the further flange into the lower hook on the carrier and swing the closer flange up while pushing it into the bottom hook. Repeat these steps to continue installing rows of planks across the space (**Fig 12**). The Open Reveal planks should always be installed in the bottom notch of the carrier. It is recommended that two installers handle the 96" planks.

**4.1.3** It is recommended that the plank splices are staggered for optimal visual.

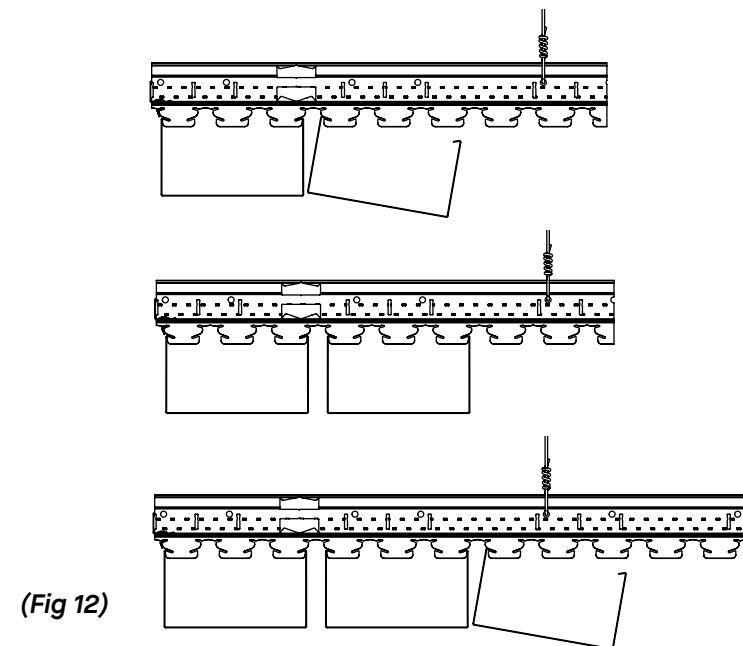

**4.1.4** Each plank must have two attachment points. Additional MBC2s may be necessary (depending on the layout) to achieve this.

## 4.2 Plank Splices

When 2", 4", 6", and 9" planks do not reach across the space in one piece, use a splice plate to join and align adjacent planks. Install planks so the factory ends are at the splice location and assure the joint is tight. Install the splice by sliding it into the end of the first installed plank. Once the adjacent plank is installed, slide the splice so it is split evenly between the two planks (**Fig 13**).

The 11" and 13" wide planks have factory upturns on the short ends and are spliced differently. Install planks so that the factory ends are tight and use vise grip clamps to temporarily hold them together. Insert sheet metal framing screws through the plank returns. This requires a clear plenum to work with power tools above the plank. Two screws are required at each splice (**Fig 14**).

## 4.3 Last Perimeter Row

The last full row of 2", 4", 6", or 9" planks must be joined end-to-end after installation but must be prepared before installation. See Section 4.3.7 for 11" and 13" wide planks.

**4.3.1** Insert the plank's appropriate splice into the flange of the first plank to be installed in the last row and pop rivet (**Fig 15**).

**4.3.2** Connect the adjacent plank with the end of the one just prepared and drill two holes for the pop rivet in the second plank of the row, but do not install the pop rivets.

**4.3.3** Install the first plank with the splice in the ceiling by using the same installation method as described in Section 4.1 (**Fig 16**).

**4.3.4** Prepare the third plank in the row as described in Section 4.3.1 and 4.3.2 above. Install the second plank in the row and insert the pop rivets in the holes prepared in Section 4.3.2.

**4.3.5** Continue this pattern for the remainder of the row. The splice installed in the next to last plank can only extend about 1/2" into the end of the last plank in the row.

**4.3.6** Color the exposed rivets to match the plank finish.

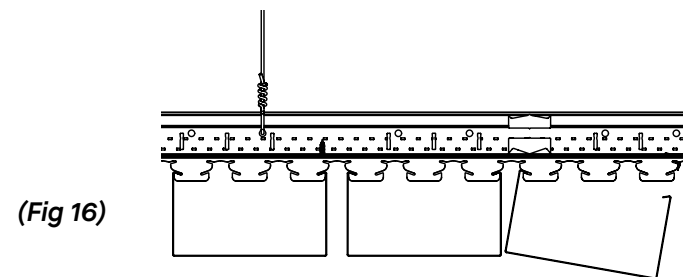
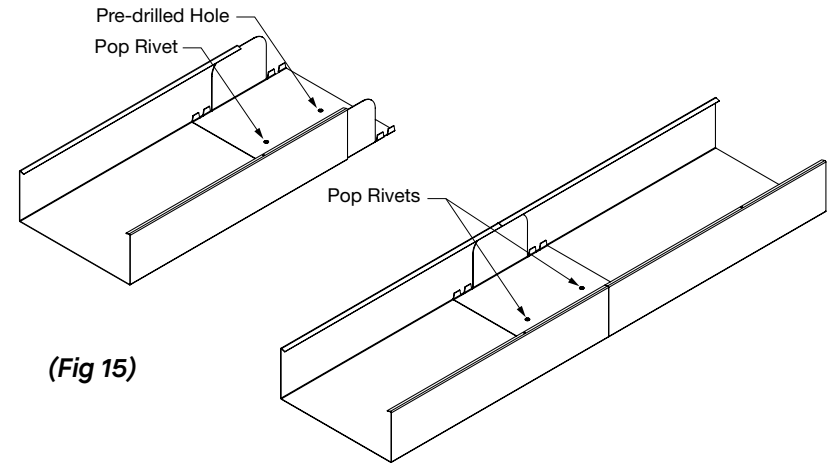
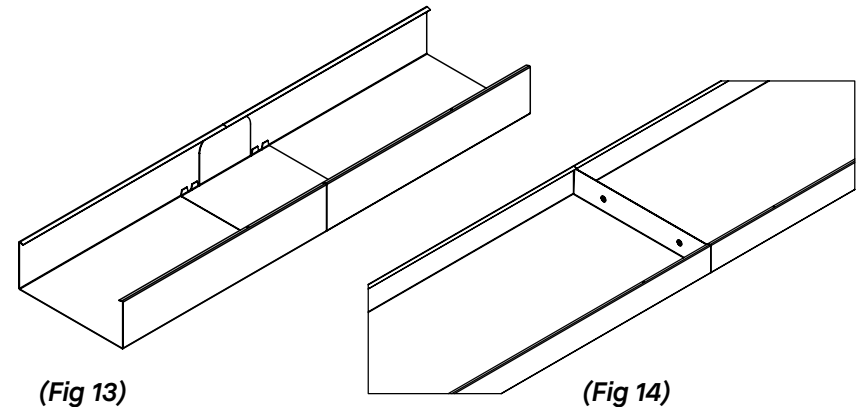

### 4.3.7 Installing 11" or 13" Planks

Cut the first plank to length so the factory upturn will be at the middle of a main carrier. Install the planks as described in Section 4.1. The splice will be directly under the main carrier to keep the joint aligned (**Fig 17**). MBC2s are installed 4' O.C. so the remaining plank joints should line up under the main carriers.

### 4.4 Optional Plank End Caps

Plank end caps can be used when the plank end is not covered by a molding. This may occur at a ceiling penetration or custom perimeter treatment, such as a floating installation. The plank end must be cut square and clean. Press the cap into the plank until it is flush with the end (**Fig 18**).

### 4.5 Optional Filler Strips

Black filler strips are field applied to the 3/4" reveals after the Diverge planks are installed. Simply push the filler strip up in between the two adjacent planks until the edges engage with the lower hooks (**Fig 19**). Filler strips can be removed after they have been installed if needed. Filler strips should be spliced underneath an MBC2.

## 5. FIELD CUTTING INSTRUCTIONS

**5.1 NOTE:** It is not recommended to rip a plank. All planks should be installed as a full-size width plank.

**5.2 The following tools can be used to make cuts in the field:**

- Circular Saw: Recommended field cutting method for cross cuts for planks up to 2" in depth. Use a 7-1/4" metal cutting blade for thin-walled material, such as Admiral™ (Item 62736) or equal.
- Compound Miter Saw: Recommended field cutting method for cross cuts for planks up to 9" in width. Use a 12" metal cutting blade for thin-walled material, such as Diablo D1296L or equal. **NOTE:** Cuts are best achieved with the plank face up and when started at the corner of the plank.
- Band Saw: Field cutting method for cross cuts. Use a non-ferrous metal cutting blade for thin-walled material.
- Tin Snips: Field cutting method for cross cuts
- Hole saw: Field cutting method for use in can light or sprinkler locations

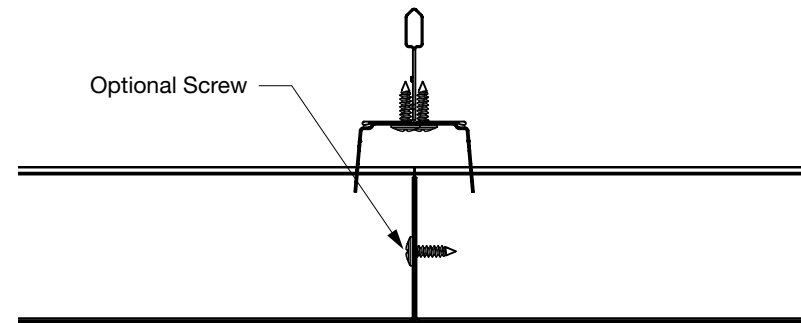

(Fig 17)

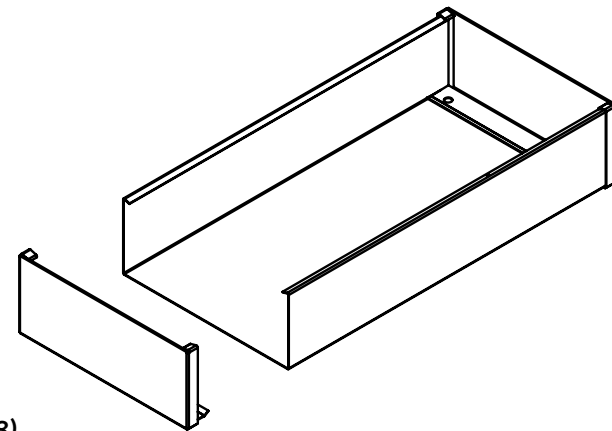

(Fig 18)

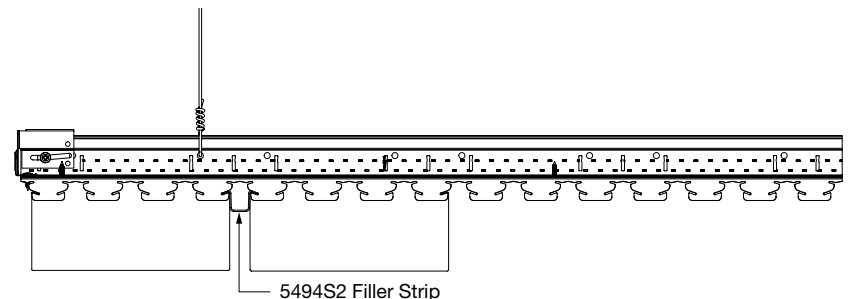

(Fig 19)

### 5.3 Safety

**CAUTION:** Cut edges of metal parts can be extremely sharp. Handle metal carefully to avoid injury. Always wear safety glasses and gloves when working with metal.

**5.4 NOTE:** Inserting blocks on the inside of the plank will help secure the plank walls and minimize chatter when cutting.

**5.5** Make sure plank is supported on a clean surface when making cuts to minimize the risk of blemishes or scratches.

**5.6** Make sure plank is properly held down with clamps to minimize movement while cutting.

**5.7** It may be necessary to deburr the edge for proper fit and safety if a clean cut is not achieved.

**5.8** Cutouts in the center of the plank are created by first drilling or punching a hole near the center and then cutting in a spiral pattern to the finished size and shape. Exercise caution during this procedure as the hand will be near the cut edge of the plank. This procedure can be followed for cutting in can lights. Sprinkler cutouts can be made with hole saw with appropriate metal blade. Standard 1" deep planks are recommended for use in can light or sprinkler locations.

### 5.9 Made-to-Order Planks

Made-to-order planks that eliminate the need for field modification of standard planks are available. Contact [ASQuote@armstrongceilings.com](mailto:ASQuote@armstrongceilings.com) for more information.

## 6. ACCESS PLANKS

**6.1** Access planks must be installed in a 4' x 4' grid opening. Maximum access plank size is dependent on the size of the plank installed in the space but must fit within the 4' x 4' grid opening. See the following chart for the recommended access plank size based on the plank width. Plan the size and location carefully to ensure that all above- ceiling equipment requiring service is reachable.

4' x 4' ACCESS PLANK			
Plank Size	Access Plank Size	Number of Planks Needed	Main Beam Carrier 2 Length
2" Plank	44" x 45"	20	45"
4" Plank	44" x 45"	10	45"
6" Plank	44" x 47-1/4"	7	47-1/4"
9" Plank	44" x 45"	5	45"
11" Plank	44" x 45"	4	45"
13" Plank	44" x 40-1/2"	3	40-1/2"

### 6.2 Access Plank Construction

**6.2.1** Cut planks to 44" in length.

**6.2.2** Cut two MBC2s to specified length in chart above, making sure not to cut a hook in half; all hooks must be full-size hooks.

**6.2.3** Install the first cut plank to the cut MBC2s making sure that they will line up with the planks in the field of the ceiling.

**6.2.4** Space the cut carriers 30" O.C. apart with 7" O.C. of exposed ends of the cut plank on either side.

**6.2.5** Install the remaining cut planks to the cut MBC2s.

**6.2.6** Fasten a framing screw in the top of each plank's flange on either side of the MBC2. This will secure the cut planks position in the carrier.

**6.2.7** Once all cut planks are installed, fasten two pieces of grid to the MBC2s to act as support pieces to strengthen the access plank. For best results, arrange the grid pieces to form the shape of a triangle.

**6.2.8** Cut two pieces of cold-rolled channel to 54" and connect them to the top of the cut MBC2s with the Up-Tight Clip (Item UTC), making sure to space the cold-rolled channel evenly across the main beam carrier. Fasten at least two screws through the UTC into the cold-rolled channel to secure the connection. NOTE: Insert a screw through the bulb of the grid on either side of the UTC to ensure it does not slide.

**6.2.9** The access plank is now ready to be integrated into the system (**Fig 20**). Install the access plank as you would a normal acoustical ceiling tile, with the bottom of the cold-rolled channel resting on the top of the neighboring MBC2s. **NOTE:** Due to the size and possible weight of the access plank, it is recommended to have two people remove and reinstall the access plank.

### 6.3 Custom-Sized Access Planks

**6.3.1** A custom-sized access plank can be created in the field if so desired if it fits within the prescribed grid size opening.

**6.3.2** It is recommended to keep the 44" length described above, but the width of the access plank can be adjusted, or the "Number of Planks Needed" as shown in the chart.

**6.3.3** Once the width has been selected, cut the carriers so there are enough full-size hooks to house the number of planks needed.

**6.3.4** Follow the same instructions listed in Section 6.2 to construct the access plank.

## 7. FLOATING TRIM / DISCONTINUOUS CEILINGS

For a cloud or discontinuous installation, the MetalWorks™ Linear – Diverge™ system can be capped with Axiom® trim (**Fig 21 and 22**). It is recommended to only cap and hide the visual of the end of the carrier with Axiom Trim, and not a plank for visual aesthetics. The offset from the main carrier flange to the bottom of the carrier hook is about 1-1/32". The Adjustable Trim Clip (Item 7239) must be used to accommodate this drop. This clip takes the place of AXTBC clips but can adjust to within 1/8" increments to hold the trim at different heights relative to the carrier flange. Refer to the Axiom Classic installation instructions for detailed trim, clip, and support wire installation instructions.

**NOTE:** Planks must never be rip-cut. Perimeter planks must always be full-size width planks. Plan the cloud or discontinuous perimeter accordingly.

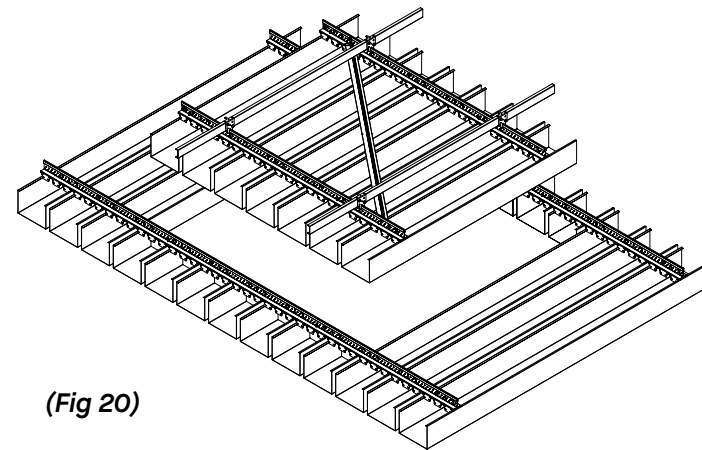

(Fig 20)

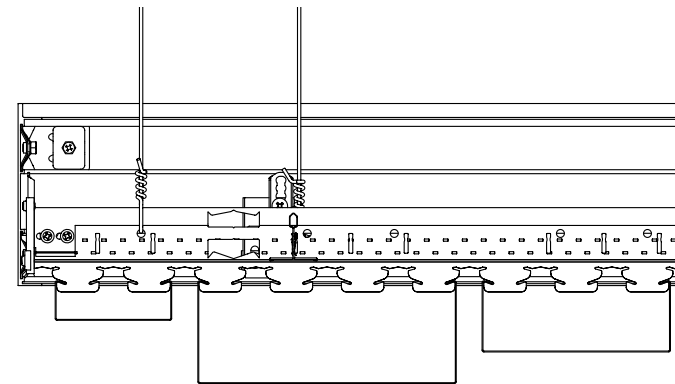

(Fig 21)

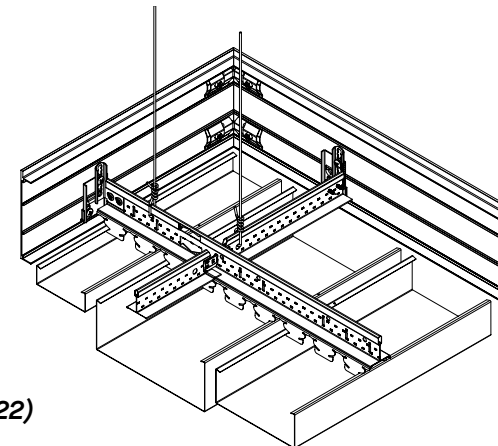

(Fig 22)

## 8. MEP INTEGRATION

**8.1** Mechanical fixtures such as diffusers, speakers, and sprinklers should be installed into the plenum area before installing the MetalWorks™ Linear – Diverge™ system. Fixture weight or housing must not be supported by the planks. Any integrated MEP fixtures must be independently supported.

Penetrations through linear metal planks are made using typical metal working equipment. Hole saws work well for sprinklers. Tin snips can be used for larger openings. All penetrations should be fitted with escutcheons that conceal the cut plank edges.

### 8.2 Lighting Integration

Please see the supplemental installation instructions for MetalWorks Linear – Diverge Lighting Integration.

The installation of this ceiling system and the integrated lighting solution will require coordination between the ceiling contractor and the electrical contractor. MetalWorks Linear – Diverge planks with the integration is a progressive installation, meaning the lights and the planks must be installed at the same time. The general contractor should work with the electrical contractor and ceiling contractor to clearly assign responsibilities.

## 9. SEISMIC INSTALLATION

MetalWorks Linear – Diverge has been engineered and tested for applications in all seismic areas based on the following installation procedures.

The following installation guidelines should be used in areas where anticipated seismic activity will be moderate to severe (IBC Seismic Design Categories C, D, E, and F). Consult the local building code department to ensure compliance with their unique requirements.

### 9.1 Seismic Suspension System

The following requirements are in addition to the installation instructions listed in this guide, ASTM E580, and the Armstrong® Seismic Ceiling Installation Guide requirement for a ceiling system.

Layout of the grid system is the same regardless of the linear plank selected. MetalWorks Linear – Diverge has only been tested for a flat installation in IBC Seismic Categories (C, D, E, and F).

### 9.2 Seismic Components

- 12' Main Beam Carrier 2 (Item 7277)
- 4' Drywall Grid Cross Tee (Item XL8945P)
- 2' Drywall Grid Cross Tee (Item XL8926)
- BERC2 Clip (Item BERC2)
- 7/8" Wall Angle Molding (Item 7800)

### 9.3 Suspension System General Requirements

- MBC2s must be installed 48" O.C., perpendicular to the desired plank length direction
- The first and last MBC2 must be installed within 24" of the perimeter wall
- Install 4' DGS Cross Tee (Item XL8945P) at 48" O.C. with the first tee no more than 24" from the wall
- Install BERC2 Clips over all grid connections to the wall (**Fig 23**). Two screws must fasten the BERC2 Clip to the wall.
- MBC2s and cross tees must be mechanically attached to the molding on two adjacent walls (**Fig 24**)
- The opposite unattached walls must have 3/4" clearance (**Fig 25**)
- Perimeter wires must be installed to support all MBC2s and cross tees within 8" of the wall
- All continuous ceilings over 1,000 SF will require compression posts per ASTM E580

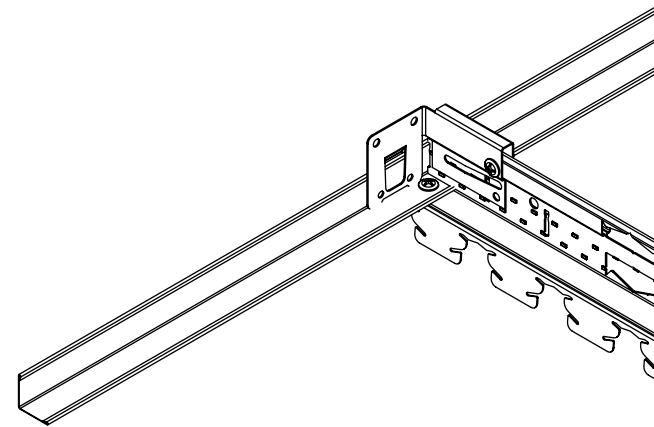

(Fig 23)

### 9.4 Seismic Linear Plank

MetalWorks™ Linear – Diverge™ planks in the field require no additional considerations. Please follow the installation steps described in Sections 3 and 4 of this guide for general requirements.

- 9.5** Seismic testing conducted at the Structural Engineering Earthquake Simulation Laboratory, located at the State University of New York – Buffalo campus, produced satisfactory results with the guidelines listed above.
- 9.6** Please contact Techline for a White Paper if positive connection from the plank to the carrier in seismic areas is required.

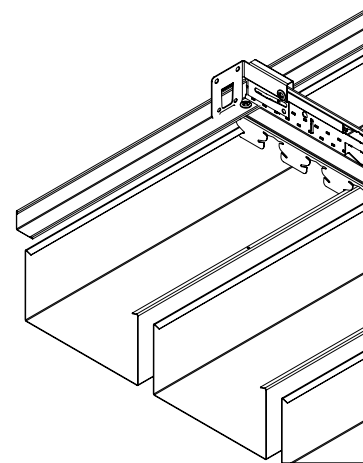

Attached wall, screw through BERC2 and bulb of MBC2

(Fig 24)

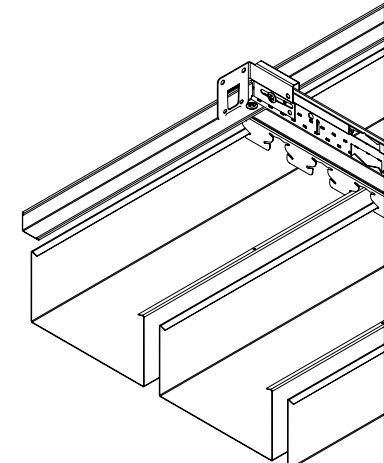

Unattached wall, screw through BERC2 slot

(Fig 25)

Item No.	Description	Included with Planks	Required for Install	Sold by the:	Pcs/Ctn
<b>MetalWorks™ Linear – Diverge™</b>					
8222A21	96 × 2 × 1" MetalWorks Linear – Diverge Plank	–	–	Ctn	16
8222A22	96 × 2 × 2" MetalWorks Linear – Diverge Plank	–	–	Ctn	8
8222A41	96 × 4 × 1" MetalWorks Linear – Diverge Plank	–	–	Ctn	8
8222A42	96 × 4 × 2" MetalWorks Linear – Diverge Plank	–	–	Ctn	8
8222A43	96 × 4 × 3" MetalWorks Linear – Diverge Plank	–	–	Ctn	6
8222A44	96 × 4 × 4" MetalWorks Linear – Diverge Plank	–	–	Ctn	6
8222A61	96 × 6 × 1" MetalWorks Linear – Diverge Plank	–	–	Ctn	8
8222A62	96 × 6 × 2" MetalWorks Linear – Diverge Plank	–	–	Ctn	6
8222A63	96 × 6 × 3" MetalWorks Linear – Diverge Plank	–	–	Ctn	4
8222A64	96 × 6 × 4" MetalWorks Linear – Diverge Plank	–	–	Ctn	4
8222A91	96 × 9 × 1" MetalWorks Linear – Diverge Plank	–	–	Ctn	6
8222A92	96 × 9 × 2" MetalWorks Linear – Diverge Plank	–	–	Ctn	6
8222A93	96 × 9 × 3" MetalWorks Linear – Diverge Plank	–	–	Ctn	4
8222AB1	96 × 11 × 1" MetalWorks Linear – Diverge Plank	–	–	Ctn	4
8222AB2	96 × 11 × 2" MetalWorks Linear – Diverge Plank	–	–	Ctn	4
8222AD1	96 × 13 × 1" MetalWorks Linear – Diverge Plank	–	–	Ctn	4
8222AD2	96 × 13 × 2" MetalWorks Linear – Diverge Plank	–	–	Ctn	4
<b>Suspension System Components</b>					
7277	12' Main Beam Carrier 2 (MBC2)	No	Yes	Ctn	10
XL8945P	4' Drywall Grid Cross Tees	No	Yes	Ctn	36
XL8926	2' Drywall Grid Cross Tees	No	Based on design	Ctn	36
7800	12' Angle Molding	No	Yes	Ctn	30
<b>Accessories</b>					
Various	Splice Plates (see data page)	No	Based on design	Ctn	10
Various	End Caps (see data page)	No	Based on design	Ctn	10
BERC2	2" Beam End Retaining Clip	No	Seismic	Ctn	200/50
UTC	Up-Tight Clip	No	Access Panel	Ctn	250
	Cold-Rolled Channel	No	Access Panel	Not sold by Armstrong	

## MORE INFORMATION

For more information, or for an Armstrong Ceilings representative, call 877 276-7876.  
For complete technical information, detail drawings, CAD design assistance, installation information, and many other technical services, call TechLine customer support at 877 276-7876.

All other trademarks used herein are the property of AWI Licensing LLC and/or its affiliates.

© 2026 AWI Licensing Company Printed in the United States of America

BPLA-292539-326



**Armstrong**<sup>®</sup>  
World Industries