

TECTUM® Finale™ and Finale™ PB Ceiling & Wall Panels

Assembly and Installation Instructions for 2" Thick Finale Ceiling & Wall Panels

THIS INSTALLATION GUIDE IS APPLICABLE TO THE FOLLOWING PRODUCT LINES: TECTUM FINALE AND TECTUM FINALE PB. ALL REFERENCES FROM HERE ON OUT WILL BE IDENTIFIED AS ("TECTUM FINALE PANELS").

1. GENERAL

1.1 Product Description

Tectum® Finale™ ceiling and wall panels are highly impact-resistant panels made of Aspen wood fibers held together with a cementitious binder. Standard Tectum Finale panels for walls and ceilings are 2" thick and available in nominal sizes of 2' x 4', 2' x 8', 4' x 4', and 4' x 8'. See data page to identify which panel sides are beveled (*Fig 1*). Panels have built-in Tectum furring strips surrounding 1" thick insulation to enhance the inherent acoustical performance of the panel, as well as speed up installation since the furring strips are pre-installed.

NOTE: It is recommended that Tectum panels are installed beveled edge to beveled edge. Square edges should only be used around the perimeter of installations.

Custom panels are available in additional sizes and thicknesses upon request (ASQuote@armstrongceilings.com).

Standard panels are available in two colors: White and Natural. Please note, Natural and White panels will show normal color variation due to the wood fibers.

Tectum Finale panels are installed using Tectum screws on furring or other appropriate fasteners when attaching directly to the structure. See Sections 4 & 5 for more details on installation. Depending on mounting method, standard ceiling and wall 2" thick Tectum panels provide an NRC (Sound Absorption) ranging from 0.85 to 0.95. Thicker custom options can provide an NRC of up to 1.0 (contact your local Armstrong Ceilings distributor). Panels can be field cut and field painted up to six times without impacting acoustic or fire performance (see Section 7.4).

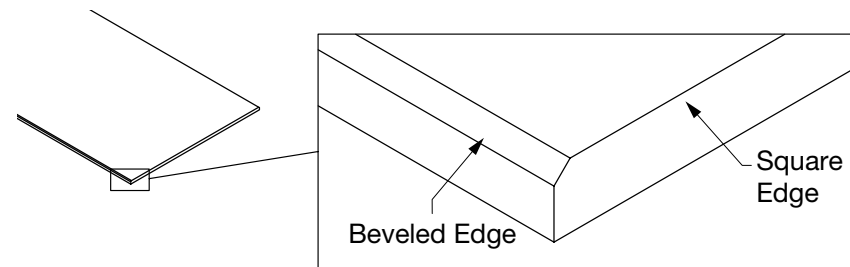

(Fig 1)

1.2 Safety

These products are made of wood fibers and cementitious binder. Sawing, sanding, or machining these products can produce wood dust and crystalline silica. Airborne dust can cause respiratory, eye, and skin irritation. Respirable wood dust and crystalline silica are classified as carcinogens. Personal protective equipment includes safety glasses or goggles, and impervious gloves. Respiratory protection may be required and depends on how the product is being cut and handled. Job site environmental conditions must be evaluated in determining what type of respiratory protection is required. In all cases, cutting is to be performed in a well-ventilated area and power tools must be equipped with a dust collection system. Refer to the Safety Data Sheet at www.armstrongceilings.com/tectum for additional information.

1.3 Warranty

Failure to follow the Armstrong Ceilings recommended installation instructions in effect at the time of installation may void the product and/or ceiling system warranty.

1.4 Surface Finish

Tectum panels are made of wood fibers within a cementitious binder. White panels are finished with a latex-based paint. Due to the unique porous composition of Tectum panels, they can be field painted up to six times without negatively impacting acoustic or fire performance.

NOTE: The edges of Tectum panels are not fully painted. For installations where finished painted edges are required see Section 7.4 for field painting guidance.

1.5 Storage & Handling

Panels should be stored in a dry interior location and shall remain in cartons prior to installation to avoid damage. The cartons should be stored in a flat, horizontal position.

Proper care must be taken when handling to avoid damage and soiling. Do not store in unconditioned spaces with humidity greater than 85% or lower than 25% RH, and temperatures lower than 32°F or greater than 120°F. Panels must not be exposed to extreme temperatures, for example, close to a heating source or near a window where there is direct sunlight.

1.6 Site Conditions

Tectum panels are required to reach room temperature and have stabilized moisture content for a minimum of 72 hours before installation. They should not, however, be installed in spaces where the temperature is lower than 32°F or greater than 120°F, or humidity

conditions are greater than 85% or lower than 25% RH. Panels must not be exposed to extreme temperatures, for example, close to a heating source or near a window where there is direct sunlight. All wet work (plastering, concrete, etc.) must be complete and dry.

1.7 HVAC Design & Operation, Temperature & Humidity Control

Real wood and wood composite products are natural building materials and they will react to changes in humidity. Spaces with installed product should be maintained with humidity in a range between 25% and 85% RH and temperatures in a range between 32°F and 120°F. Wood tends to contract with lower humidity and expand with higher humidity.

Cementitious wood fiber panels may also have a tendency to warp, twist, or bow, due to the natural stresses in the components and these humidity changes. Be aware of these natural tendencies when evaluating the products. It is also necessary for the area to be enclosed and for the HVAC systems to be functioning and in continuous operations for the life of the product. All wet work (plastering, concrete, etc.) must be complete and dry. Standard 2" Tectum® Finale™ panels cannot be used in exterior applications. Contact TechLine for information on custom Tectum products available for exterior installations.

1.8 Colors

Standard Tectum Finale panels are available in Natural and White finishes. Due to the natural variation of Tectum wood fibers, Natural and White panels will have normal color variation from panel-to-panel and within panels.

Panels can be field painted up to six times without losing their acoustical or fire performance. See Section 7.4 for field painting guidelines. Factory-finished custom colors are also available (ASQuote@armstrongceilings.com).

2. DESIGN CONSIDERATIONS

2.1 Directionality

See data page to identify which panel sides are beveled. Panels should be installed beveled edge to beveled edge. In installation layouts where this is not possible, ashlar patterns are required. **NOTE:** Cutting a beveled edge in the field may be required based on the layout of the panels. See section 7.2 for cutting recommendations.

2.2 Edges

Exposed edges of an installation are not factory painted. See Section 7.4 for guidance on field painting.

2.3 Pool Installations

2" thick Tectum® Finale™ ceiling and wall panels can be used in pool areas or other high-humidity areas where standing water is present. Review the "TECTUM® Direct-Attach Ceiling and Wall Panels for Indoor Swimming Pool Applications" installation instructions for more information.

2.4 Exterior Installations

2" thick Tectum Finale ceiling and wall panels are not intended for exterior use.

2.5 Direct Attachment

Tectum Finale panels are mechanically fastened to furring (metal or wood) or direct to structure using appropriate fasteners. Finale panels are approximately 3.1 lbs/SF. Correct fasteners should consider total system weight. Do not countersink screws or fasteners into panel face. The type and position of framing and furring will be specified by the contractor.

3. TECTUM ACCESSORIES

3.1 Screws

Armstrong® Ceiling and Wall Systems offers three types of screws for many common installation methods. For specific installation instructions, including which screw for furring to structure connection and spacing, please see Section 4.

Sharp point screws (item 8187L30) are 3" long and are available in coordinating factory-finished White (suffix TWH) or Natural (suffix TNA). For 20- and 25-light-gauge steel framing, wood furring, or Armstrong Ceilings drywall grid, use 3" sharp point drywall screws. **(Fig 2)**

Drill point screws (item 8188L30) are 3" long and are available in coordinating factory-finished White (suffix TWH) or Natural (suffix TNA). For 20-gauge structural and heavier steel decking or framing, use 3" self-drilling drywall screws. **(Fig 3)**

CMU Screws (item 8189L32) are 3-1/4" long and are available in coordinating factory-finished White (suffix TWH) or Natural (suffix TNA). For hollow block CMU (Cement Masonry Unit or breeze/cinder block) structures, use 3-1/4" masonry screws. See specific installation guidance in Section 4.1. **(Fig 4)**

To attach Tectum panels to structures or surfaces not listed in this section, please contact a fastener manufacturer, such as Hilti™, Fastenal®, or TapCon® to obtain guidance and engineering data support.

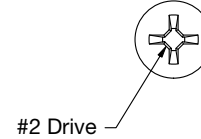

(Fig 2)

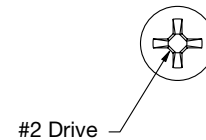
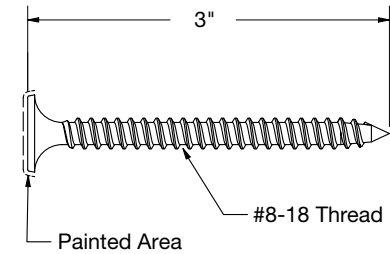

(Fig 3)

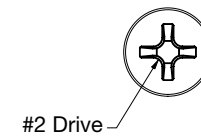
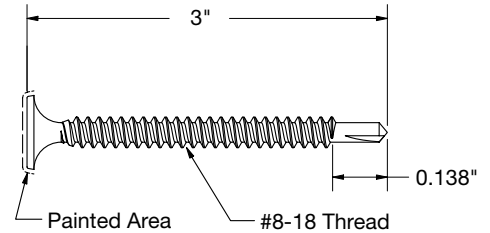

(Fig 4)

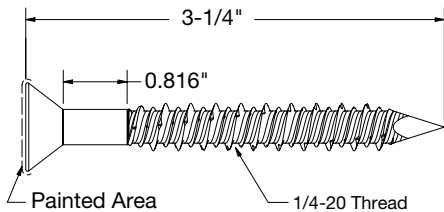

4. INSTALLATION OPTIONS

For Tectum® Finale™ panels, the only recommended installation option is screw attachment to furring or DGS that is secured to structure (ceiling or walls). The furring can be either wood or metal. Finale panels are approximately 3.1 lbs/SF. Consider total system weight when determining fasteners. The furring enables improved sound absorption and allows the installer to fasten in areas where there could otherwise be obstructions. The use of screw attachment for interior panels is widely accepted. The proper installation of the screws results in an installation where the heads are difficult to find even when viewed from a short distance. The Phillips flat head screws are painted to match either the painted White panels or the Natural panels. The screws are installed so that the screw head is flush with the surface of the Tectum panel. **Do not countersink the screw heads.** The texture of Tectum panels helps hide the screw head. This installation section will review the different mounting methods and fastener recommendations.

NOTE: Tectum Finale panel edges are not factory painted. In installations where the sides of the panels are to be exposed they may need to be addressed with trim or field painting, referenced in Section 7.4.

4.1 Mounting Method A

Mounting Method A requires installing panels directly to a wall structure with no furring or space behind the Tectum Finale panels (*Fig 5*). Please consult this section for type of screw (CMU/Drill Point/Sharp Points) and Section 4.6 for spacing requirements (for both Standard Interior and High-Impact/Abuse applications).

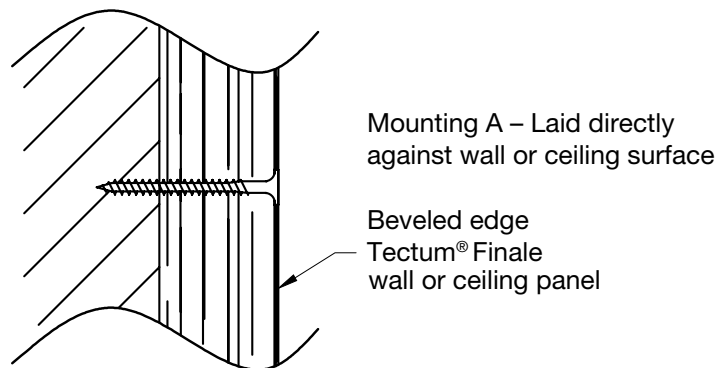

(Fig 5)

Because ceiling and wall structure materials vary greatly, Armstrong World Industries does not offer fasteners for all project applications, but does provide fasteners for the most common structures. Depending on what the substrate is, there are different recommendations for which fastener to use.

For one of the most common wall structures, CMU (hollow Cement Masonry Unit, or breeze/cinder block), use Tectum 3-1/4" CMU Screw (item 8189L32). While the CMU screw will work in a majority of concrete block applications, it is important to note that it will not work with all concrete. It is difficult or impossible to use this screw with some poured or precast concrete. Work with a fastener manufacturer to determine best fastener for your application and to acquire engineering reports regarding performance. Contact Armstrong Ceilings TechLine or TapCon® if specific guidance is needed related to drill bits, anchors, or general CMU screw installation.

For structures other than hollow CMU, contact a fastener manufacturer, such as Hilti™, Fastenal®, or Tapcon® to get guidance and engineering support data on the fastener type that will meet pull-out requirements for your building code.

IMPORTANT NOTES:

Power Actuated Fasteners: Do not use power actuated fasteners to directly attach Tectum Finale panels to masonry surfaces. If power actuated fasteners are necessary they should be used on the furring/hat channel and panels screw-attached to the furring as described in steel framing and wood furring Section 4.2.

Exterior Masonry Walls: In the event that you encounter uninsulated exterior walls, or if you are uncertain of the insulation conditions of the wall, use furring strips to ensure an air gap between panels and the structure to minimize unwanted condensation-related issues.

For fastener spacing requirements for standard interior and high-impact spaces, see Section 4.6.

4.2 Mounting Method D-20

The D-20 Finale™ mounting method includes beveled-edge wall panels laid on 3/4" furring strips, or Drywall Grid (item 8906 main beam and XL8945 cross tees) to maintain air gap between structure and back of the Tectum panels (*Fig 6*). The furring or DGS must be attached to structure in a method that supports the full weight of the panels per the requirements specified in Section 4.5. Contact a fastener manufacturer, such as Hilti™, Fastenal® or TapCon® to ensure the correct fastener for the structure type, since structure fastener requirements can vary. Due to joist/stud spacing in most jobs, to meet fastener layout requirements furring strips are recommended to ensure a secure fastening location for the panels. If you are attaching to existing drywall, all fasteners must go into a stud, drywall grid, or other structural component. It is the responsibility of the contractor to locate these elements in either ceiling or wall applications.

Please consult the following sections for attaching the Tectum Finale panels to the type of furring selected (Drill Point/Sharp Points) and Section 4.6 for spacing requirements (for standard interior or high-impact/abuse spaces):

Attach Tectum Finale panels directly to 3/4" wood or metal hat channel furring (see Section 4.6 for screw spacing/guidance):

- Wood furring: In a D-20 mounting, to attach to wood furring, use Tectum 3" sharp point screws (item 8187L30) with coordinating painted face
- Light Gauge (20-25 gauge) Metal furring/framing: In a D-20 mounting, attach to thin gauge metal furring with Tectum 3" sharp point screws (item 8187L30) with coordinating painted face
- Drywall Grid furring: In a D-20 mounting, attach to thin-gauge metal furring with Tectum 3" sharp point screws (item 8187L30) with coordinating painted face
- Heavy-gauge metal furring: In a D-20 mounting, attach to heavy-gauge metal furring with Tectum 3" drill point screws (item 8188L30) with coordinating painted face.

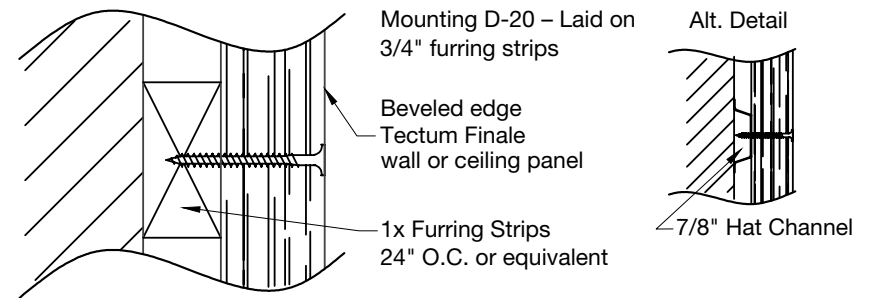

(Fig 6)

4.3 Panel Direction & Fastener Layout

Recommended screw spacing is such that one screw supports one square foot to three square feet of panel. The 2" thick standard Tectum® Finale™ ceiling and wall panel has a weight of 3.1 lbs/SF. It is the contractor/installer's responsibility to ensure type of fastener and placement is able to carry the system weight. Additionally, the Tectum Finale panel surface is not intended to support additional weight. Because the pull-through resistance of the screw head is adequate, no washers or adhesive application is required.

Horizontal Wall Panel Installation

Tectum Finale panels should be fastened a minimum of 24" O.C. starting at the edge of the panels. When furring is used it should be installed perpendicular to the long side of the panel. Tectum Finale panels are required to be installed in an ashlar pattern (staggered end joints). Furring is required at the ends of the panels. (Fig 7)

Vertical Wall Panel Installation

Tectum Finale panels should be attached at a maximum 24" O.C. on the vertical dimension and 23-3/4" on the horizontal dimension.

Installation Recommendations

It is recommended that Tectum panels are installed beveled edge to beveled edge. Square edges should only be used around the perimeter of installations. **NOTE:** Cutting a beveled edge in the field may be required based on the layout of the panels. See section 4.6 for cutting recommendations.

NOTE: Use Beveled Edge/Beveled End panels for all adjoining panel installations (Fig 8).

NOTE: Use Beveled Edge/Square End for the panel layout in (Fig 9).

NOTE: Stacked bond patterns are possible, but not recommended. Field trimming panels may be required to achieve desired fit and alignment (Fig 10).

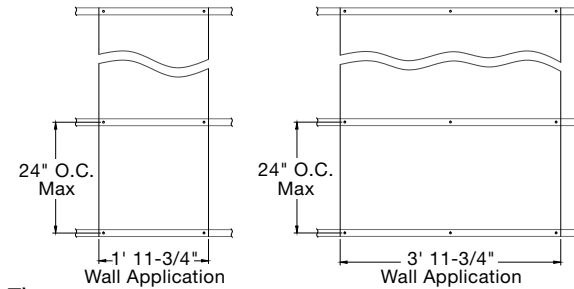

(Fig 7)

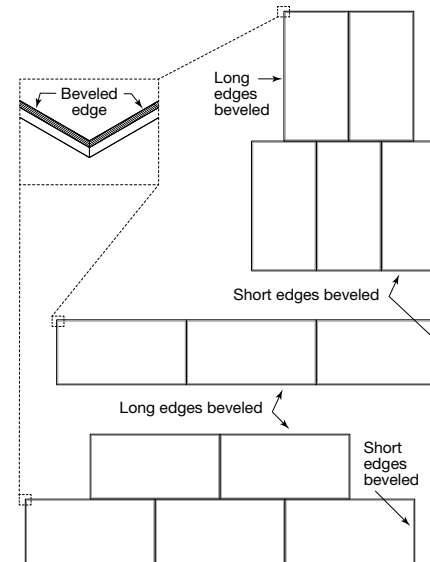

(Fig 8)

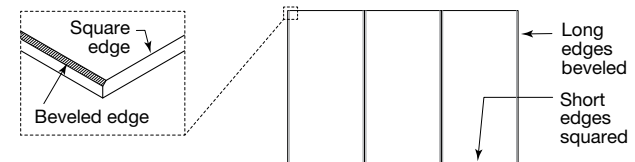

(Fig 9)

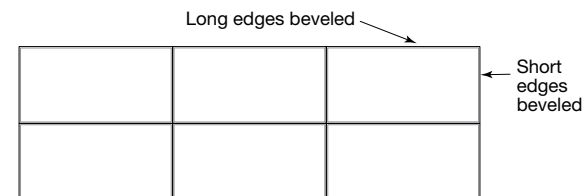

(Fig 10)

4.4 Screw Placement for ALL Mounting Methods

Tectum interior panels are typically installed over furring but the same screw pattern should be used for a Type A direct mounting. The recommended method is for the furring to be spaced not over 24" O.C. and perpendicular to the panel direction in standard use spaces. Please see Section 4.7 for screw spacing recommendations for high impact areas. Furring is required at the panel ends. The attachment of the furring and the furring must be designed to support the weight of the panels. If furring must be installed parallel to the panel direction, the spacing must match the panel width.

A panel 47-3/4" must have mid-width furring. Spacing should be as follows for furring parallel to Tectum® Finale™ panels:

- 23-3/4" width 23-3/4" center-to-center spacing
- 47-3/4" width 23-7/8" center-to-center spacing

When attaching to furring use painted head drywall screws. For wall applications on 23-3/4" wide panels, two screws per furring crossing are required; for 47-3/4" wide panels, three screws per furring crossing are required (**Fig 11**). The screws are to be spaced 1" from the panel edges and where three (3) are required, the third screw is centered. For ceiling applications using 23-3/4" wide panels, three (3) screws per furring crossing are required. For ceiling applications using 47-3/4" wide panels, five (5) screws per furring crossing are required.

NOTE: Short side of panel (panel width) is undersized at 23-3/4" or 47-3/4", while long side of the panel is 48" or 96".

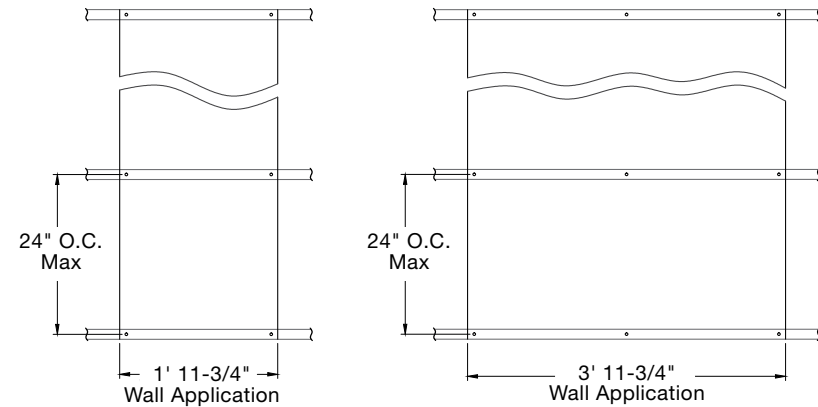

(Fig 11)

4.5 Staggered End Joints (Ashlar Pattern)

All Tectum® Finale™ wall panels are required to have staggered end joints if more than one panel is installed.

4.6 Field Cutting

Tectum panels are easily cut using standard wood cutting tools. The short ends of panels (23-3/4" side for 2' x 4' and 47-3/4" side for 4' x 8' panels) will be square edges from the plant and will require a hand router with a 1/4" bevel bit to replicate the 1/4" bevel in the field, if required.

4.7 High-Impact Areas

Furring or fastener attachment is required at 16" O.C. in lieu of 24" O.C. as described in section 4.4 for all 2" panels (*Fig 12*).

5. FINALE – CEILING MOUNTING METHODS

Mounting Tectum Finale panels to the ceiling follows the same fastener and mounting methods that are listed for walls in Section 4; however, the screw layout for any direct-attached ceiling panel should be mechanically fastened every 12" O.C. Metal or wood furring or Armstrong Ceilings Drywall Grid should be installed perpendicular to panel direction no more than 24" O.C. Once furring or grid is installed, place panel on furring, making sure panel ends fall over furring strips or grid members.

Tectum Finale panels must be installed in an ashlar pattern (staggered panel ends).

Mechanically attach panels every 12" O.C. to furring placing screw heads flush with the face of the Tectum Finale panel. **Do not countersink screws.** Place the next panel against the furring, butting the end to the previously installed panel. Any time a Tectum Finale panel touches another Tectum Finale panel, the end should be beveled. Mechanically fasten the second panel every 12" O.C. (*Fig 13*)

5.1 Direct-Attach to Armstrong Ceilings Drywall Grid System

The requirements listed here represent the manufacturer's minimum acceptable installation recommendations, and may be subject to additional requirements established by the local authority having jurisdiction.

- All installations shall follow ASTM C636
- Suspension components should be tested per ASTM E3090 with duty ratings per ASTM C635

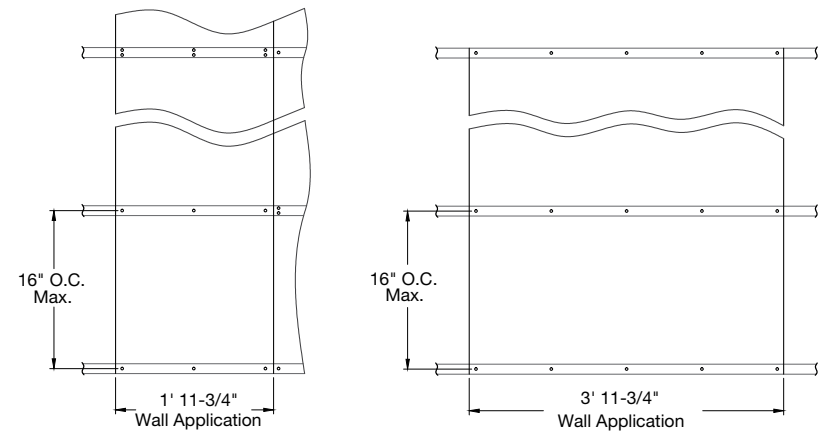

(Fig 12)

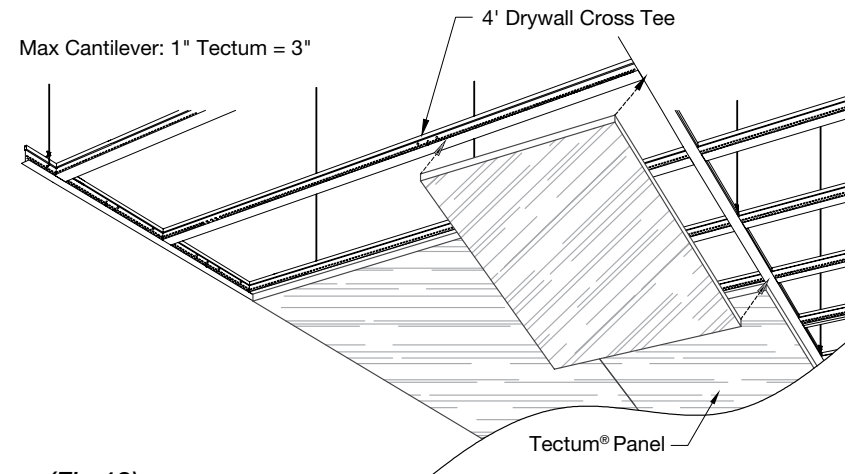

(Fig 13)

Use Armstrong Ceilings Drywall Grid main beam (item HD8906) along with drywall grid cross tees (item XL8945) and (KAM-12) Angle Molding. The panel length should run parallel with the main runners and screw layout should be 12" O.C. as shown for direct-to-furring application. (Fig 14)

6. DISCONTINUOUS/FLOATING INSTALLATION

6.1 Clouds with Axiom® Trim

Due to the thickness of the panel, Armstrong® Tectum® 2" thick Finale™ panels are not recommended in discontinuous/floating ceiling installation with Axiom® Trim. See our Tectum Lay-In and Tegular ceiling panels or our 1" Tectum Direct-Attach panels for discontinuous ceiling options using Prelude® XL® suspension system along with Axiom® Trim.

7. PANELS

7.1 Edge Detail/Interface

2" thick standard Tectum Finale panels are available in nominal sizes of 2' x 4', 2' x 8', 4' x 4', and 4' x 8'. Actual width sizes are approximately 1/4" below nominal size (e.g.: 23-3/4" x 48"). See data page to identify which panel sides are beveled.

7.2 Cutting of Panels

Cut the panel using standard woodworking tools and techniques. A table saw is recommended for straight cuts and a band saw for curved cuts. In both cases, panels should be cut face up to minimize chipping of the face veneer. To replicate the 1/4" factory bevel, a hand router with a 1/4" bevel bit can be used. Fine-toothed blades recommended for finish cuts will yield the best results.

7.3 Directionality

See data page to identify which panel sides are beveled. Panels should be mounted beveled edge to beveled edge. In installation layouts where this is not possible, ashlar patterns (staggered end to end) are required. **NOTE:** Cutting a beveled edge in the field may be required based on the layout of the panels. See section 7.2 for cutting recommendations.

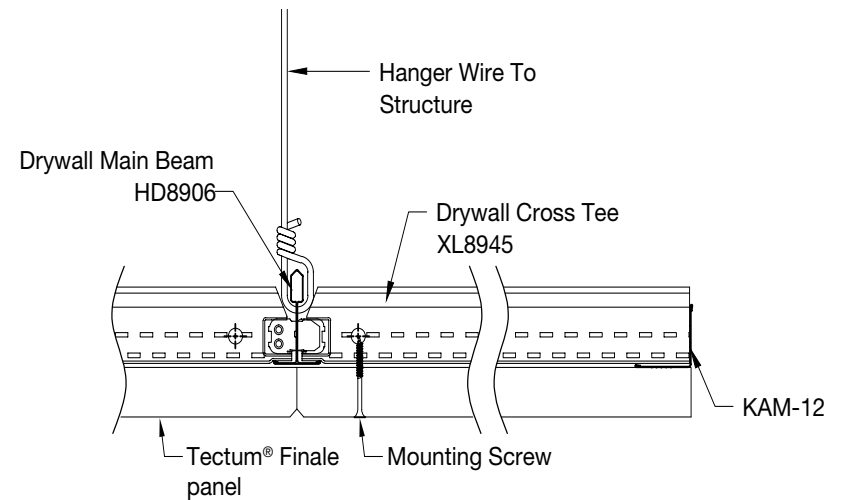

(Fig 14)

7.4 Field Painting

Field Painting Specification Recommendation:

Sherwin-Williams® Product: Waterborne Acrylic Dryfall (B42W1)
50 GAL. Drums MPI# 118 (or substitute Alkali-based, flat latex paints with similar properties)

*Tests have shown that six coats of spray-applied paint have no negative impact on the acoustical and fire properties of the Tectum panels.

Recommended Spread Rate per Coat

Wet Mils: 3.5 - 5.0

Dry Mils: 1.5 - 2.0

Coverage: 336-450 sq. ft./gallon approximate (based on flat surface)

* If necessary, cross spray at a right angle

Surface Preparation

Surface must be clean, dry, and in sound condition. Remove all oil, dirt, grease, and other foreign material to ensure adequate adhesion.

Application Condition

Temperature: 50° F minimum, 110° F maximum (air, surface, and material); at least 5° F above dew point

Relative Humidity: 75% maximum

Dry Time: 20 minutes

Recoat: 1 hour *

During the early stages of drying, the coating is sensitive to rain, dew, high humidity, and moisture condensation. Plan painting schedules to avoid these influences during the first 16-24 hours of curing.

Dryfall characteristics will be adversely affected at temperatures below 77° F or above 50% relative humidity.

Application Equipment

The following is a guide. Changes in pressure and tip sizes may be needed for proper spray characteristics.

Airless Spray:

Pressure: 2800

Hose: 1/4" ID

Tip: 0.013"

Reduction: As needed up to 10% by volume.

Conventional Spray:

Gun: Binks 95

Fluid Nozzle: 63C

Air Nozzle: 63PB

Atomization Pressure: 60 psi

Fluid Pressure: 50 psi

Reduction: As needed up to 20% by volume

Brush and Roller: Not recommended

Field Touch Up and Color Match:

Standard White Color Match: Sherwin-Williams® #SW7005

Standard Natural Color Match: Sherwin-Williams #SW6126

* Tectum® Finale™ panels should be fastened in place prior to field painting.

8. SPECIAL INSTALLATION CONSIDERATIONS

8.1 Sloped

Sloped ceiling installations should follow standard ceiling installation with screws 12" O.C. per Section 5.

8.2 Pools/Natatoriums

2" thick standard Tectum Finale panels can be used in rooms with standing water. Review the "TECTUM® Direct-Attach Ceiling and Wall Panels for Indoor Swimming Pool Applications" installation instructions for more information.

8.3 Exterior Installation

2" thick standard Tectum Finale panels are not intended for use in exterior applications.

9. SEISMIC INSTALLATIONS

Seismic installations of 2" Tectum Finale are to be handled per building code.

TECTUM® FINALE™ CEILING AND WALL PANELS – STANDARD ITEMS:				
Long Edges Beveled/Short Edges Square				
Item No. ♦	Item Name	Included with panels	Sold by the:	SF per Pallet
8215W2L04T10_ ___	23-3/4 x 48 x 1" Panel	–	Piece	1,152
8215W2L08T10_ ___	23-3/4 x 96 x 1" Panel	–	Piece	1,152
8215W4L04T10_ ___	48 x 48 x 1" Panel	–	Piece	572
8215W4L08T10_ ___	47-3/4 x 96 x 1" Panel	–	Piece	572
TECTUM® FINALE™ PB CEILING AND WALL PANELS – STANDARD ITEMS:				
8255W2L04T10_ ___	23-3/4 x 48 x 1" Panel	–	Piece	1,152
8255W2L08T10_ ___	23-3/4 x 96 x 1" Panel	–	Piece	1,152
8255W4L04T10_ ___	48 x 48 x 1" Panel	–	Piece	572
8255W4L08T10_ ___	47-3/4 x 96 x 1" Panel	–	Piece	572
TECTUM FINALE CEILING AND WALL PANELS – INSTALLATION ACCESSORIES*				
*Note: Fasteners required vary based on project details. Reference Section 4 for guidance.				
Item No. ♦	Item Name	Included with panels	Sold by the:	Pcs per Ctn
8187L30_ ___	Sharp Point Screw #8 x 3"	No	Carton	1000 pcs
8188L30_ ___	Drill Point Screw #8 x 3"	No	Carton	1000 pcs
8189L32_ ___	CMU Screw – 1/4-20 Thread x 3-1/4"	No	Carton	500 pcs
	Wood or Metal Furring Strips	Not sold by Armstrong Ceilings		

♦ When specifying or ordering, include the appropriate 3-digit color suffix TNA = Natural TWH = White (e.g. 8215W2L04T10 I W H). For four-sided beveled edge panels, special sizes and colors, call TechLine at 1 877 276 7876.

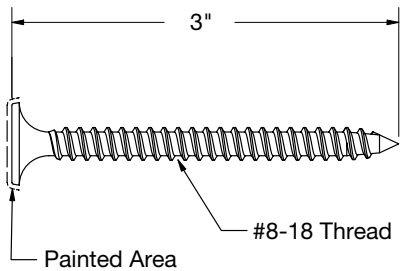

Item 8187L30

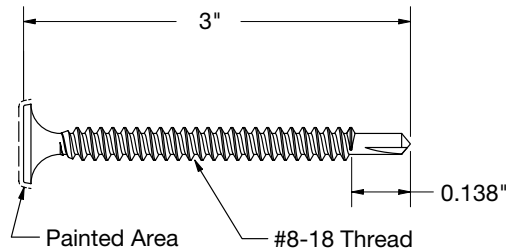

Item 8188L30

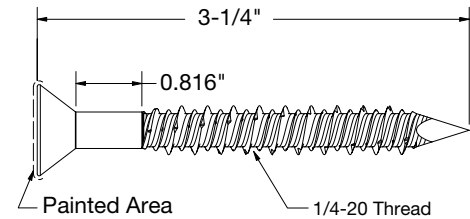

Item 8189L32

MORE INFORMATION

For more information, or for an Armstrong Ceilings representative, call 1 877 276-7876.
 For complete technical information, detail drawings, CAD design assistance, installation information, and many other technical services, call TechLine customer support at 1 877 276-7876 or FAX 1 800 572-TECH.

