

FORMATIONS® Acoustical Clouds with AXIOM® VECTOR® Perimeter Trim and Suspension System

Assembly and Installation Instructions

1. DESCRIPTION

1.1 Formations Acoustical Clouds is a perimeter trim system designed to create ready-to-assemble full panel installations for “ceiling clouds” sized from 6' x 6' up to 14' x 14'. Formations are designed to work with Armstrong Filaments™, Infusions®, Optima®, Ultima®, and MetalWorks™ products in Vector®, flat, and Tegular edges for 15/16" grid.

1.1.2 Included in the Kit are:

- Axiom® Vector® Trim, with factory-cut end details to form a cloud to the required size
- Suspension system components cut-to-length to provide for full-size installation of 24" x 24" panels
- Aircraft cable, cut to 10' length, in the amount required for the installation
- Support Hanger carrying channel, cut-to-length to accommodate installation of the aircraft cable, 24" from the vertical face of the Axiom trim
- Axiom splices to join together sections of Axiom
- Axiom Connector Clips to join suspension system components to the Axiom trim
- Axiom component diagram to properly position perimeter trim sections

NOTE: Pop-rivets, screws, and hardware required for attachment to the structure are not included. Ceiling panels are ordered separately.

Kits contain all of the components required to construct and hang a complete cloud except for the ceiling panels, the screws or pop-rivets needed to attach the clips to the grid members, and the hardware needed for attachment to the structure.

1.1.3 Most building codes require non-structural building components to be restrained. Armstrong also recommends restraint in accordance with local building code requirements. Please consult with the building code professional having jurisdiction over the project to determine appropriate restraint requirements for this installation. Restraints are not included in this kit.

1.1.4 Formations, as with other architectural features located in the ceiling plane, may obstruct or skew the existing or planned fire sprinkler water distribution pattern, or possibly delay the activation of the fire sprinkler or fire detection system. Designers and installers are advised to consult a fire protection engineer, NFPA 13, and their local codes for guidance on the proper installation techniques where fire detection or suppression systems are present.

CAUTION: Ceiling panels used in Formations Acoustical Clouds must be limited to no more than 1.25 lbs/SF. Use of panels weighing more than this stated limit could result in failure of suspension system components.

2. INSTALLATION

IMPORTANT NOTE: The Axiom Vector trim is to be installed with the flange side down when being used with an Armstrong Vector panel. Invert the trim for all other panel types so that the plane flat face is exposed (*Fig 1 and 2*).

3. PRE-ASSEMBLY

- 3.1** Study the layout drawing for the cloud and verify that kit contents are complete. Call 800-840-8521 to request replacements for missing components.
- 3.2** Review the location of the Support Hanger carrying channels. They will be located 2' from the longest side of the cloud and then 4' on center (note that in some instances this pattern will result in two Support Hanger carrying channels being positioned 2' from one another at the center of the cloud).

4. ATTACH HANGING CABLES TO STRUCTURE

- 4.1** Hanging cables (item AC1210) are located along the length of the Support Hanger carrying channel starting 1' from the end (2' from the edges of the cloud) and then 4' on centers (note that in some instances this pattern will result in two hanging cables being positioned 2' from one another at the center of the cloud).
- 4.2** Hardware for the attachment of the cable to the building structure is not provided. Cables are fitted with a loop at one end that is to be cinched to mounting hardware appropriate for the surface to which it is attached. Select hardware that will be capable of supporting a minimum of 200 pounds (*Fig 3*).

5. HANG SUPPORT HANGER CHANNELS

- 5.1** Attach the Axiom® Support Hanger (Item numbers SHC: 4, 6, 8, 10, 12) to hanging cables using the adjustable "Quick Loop" connectors (item ACHC) provided with the kit. Insert the cable through one end of the connector and then through the appropriate hanger wire hole on the support channel. Slide the cable back through the "Quick Loop" connector and adjust to the correct elevation. Follow the instructions provided with the connectors if it becomes necessary to release the cable from the connector (*Fig 4*).

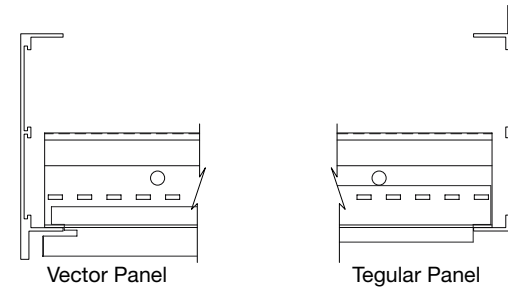

(Fig 1)

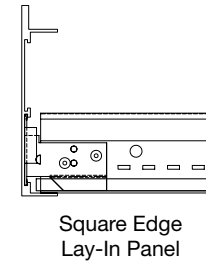

(Fig 2)

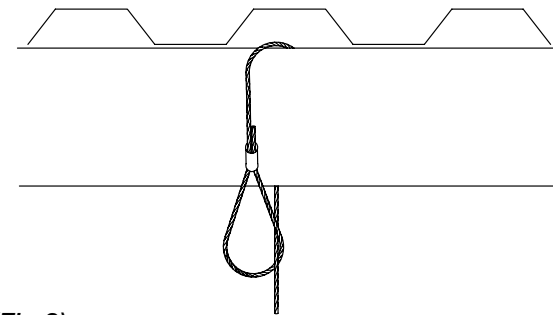

(Fig 3)

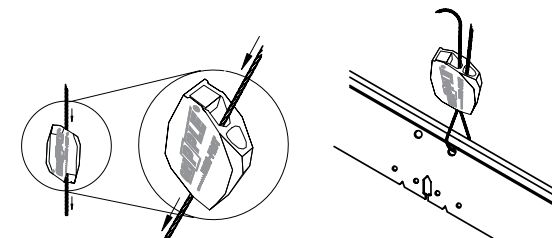

(Fig 4)

6. INSTALL MAIN BEAMS

6.1 Install main beams into the appropriate notches on the Support Hanger channels. The first main beam will be 1' from the end of the channel and the remainder will be placed at 2' centers. Slide the main beam through the notches or bend the tab on one side of the notch out of the way so that the main beam can be installed from below. Bend the tab back into position under the bulb of the main beam (Fig 5).

6.2 Attach Axiom Cross Tee Clips (item AXCCLT) to each end of each main beam by positioning as shown in the drawing. The top of the clip should touch the bottom of the bulb of the grid and the end of the main beam should contact the thumbnail stop on the clip. Secure each clip with two pop-rivets or #8 sheet metal screws (note that pop-rivets are preferred over screws because they will not interfere with the placement of the ceiling panels) (Fig 6).

7. INSTALL TEES

7.1 Install 2' cross tees between main beams. After all tees have been installed, slide the Support Hanger channel along the main beams so that it rests against the cross tees. Screw the support channel to the tees by inserting a #8 x 9/16" sharp point sheet metal screw into the holes on each side of the main beam as shown in the drawing below (Fig 7).

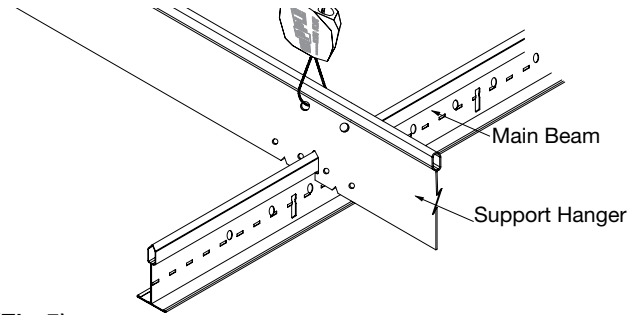

(Fig 5)

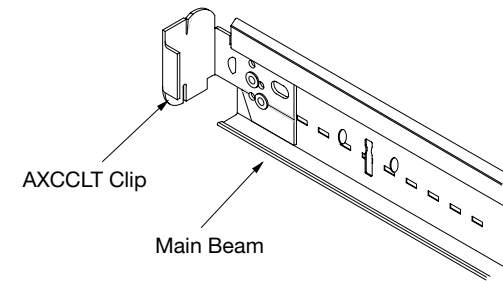

(Fig 6)

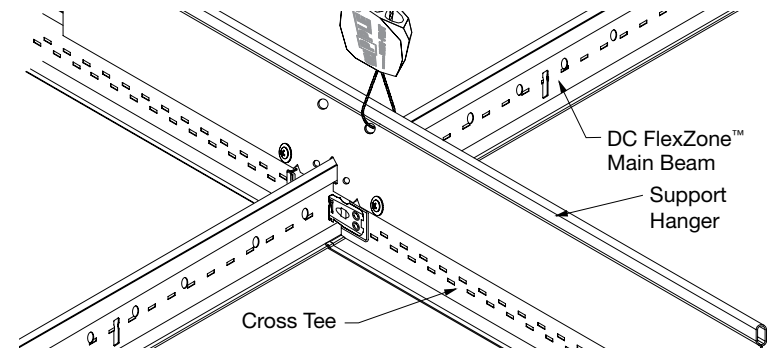

(Fig 7)

7.2 Bend the tabs at the ends of the Support Hanger as shown so that they will fit under the bottom of the bulb of the tees and secure with a #8 x 9/16" screw (**Fig 8**).

7.3 Cut away the end detail on the cross tees that will engage the Axiom® trim. Attach an Axiom Cross Tee Clip to the end of each tee as shown (**Fig 9**).

7.3.1 Note that pop-rivets are preferred over screws. Align the clip such that the lower two holes in the three-hole line match up with the holes in the end of the tee. Insert two fasteners through the tee and into the clip (**Fig 10**).

8. INSTALL AXIOM® TRIM

8.1 Use the assembly drawing provided to arrange the Axiom trim sections in the proper sequence. Mark the locations for the center line of the grid members on the inside of the trim as follows: The first tee or main beam should be located 24-5/16" from the ends of the trim. Remaining parts will be located 24" on center.

8.2 Twist the grid member, with Axiom Cross Tee Clip attached, and engage it into the bosses on the Axiom trim. Hold the tab on the clip in a pair of pliers and lock in place by twisting in the clockwise direction (**Fig 11**).

8.2.1 Repeat this process for all clips. Adjust position of installed grid members by tapping to align with center line reference marks.

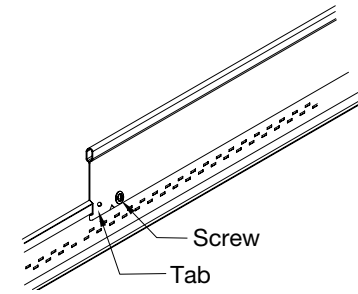

(Fig 8)

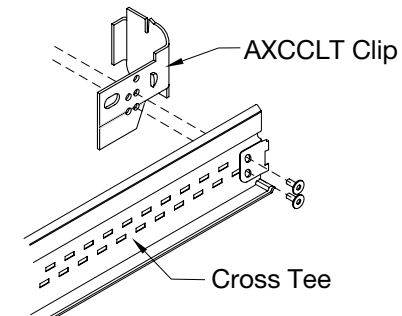

(Fig 9)

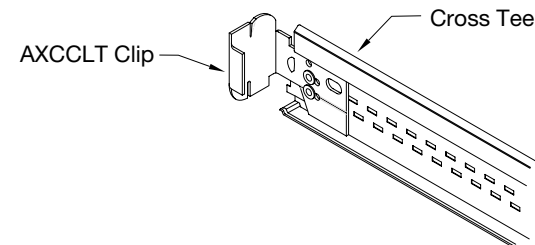

(Fig 10)

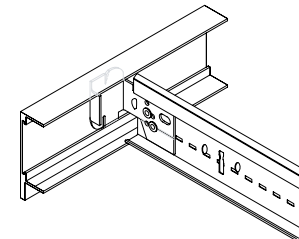

(Fig 11)

8.3 Connect sections of Axiom trim with splice plates as required. The supplied assembly drawing will show the correct quantity and location for splice plates. Corner splices must be bent to 90° before assembly (Fig 12).

8.3.1 DO NOT OVERTIGHTEN SETSCREWS. Excessive torque will result in deformation of the trim that will show on the finished surface.

9. INSTALL RESTRAINT/SEISMIC BRACING

9.1 Restraint for clouds installed on projects where anticipated seismic activity will be light (IBC seismic design categories A & B) can be accomplished by installing a pair of crossed cables 2' in from each edge of the assembly. These cables should attach to the support channels and be sloped no more than 45° from horizontal.

9.2 In areas where anticipated seismic activity will be moderate to severe, the crossed cables should be replaced with a bracing system more appropriate for the forces that will be encountered.

9.2.1 Testing conducted at the Structural Engineering Earthquake Simulation Laboratory, located at the State University of New York – Buffalo campus, produced satisfactory results with rigid bracing fabricated from 1/2" EMT conduit.

9.2.2 The tested bracing system consisted of a vertical member extending from the support channel to the structure above near each corner of the cloud. These members were positioned at the main beam/support channel intersections closest to the corners of the assembly. Two additional members were fastened to the bottom of the vertical and extended to the structure at an angle not exceeding 45° from horizontal. These members were parallel to the sides of the cloud.

9.2.3 In order to hide the bracing above the cloud, wire splay bracing can be replaced with rigid bracing. Rigid bracing only requires a post and two diagonals. This should be located at the suspension system intersection closest to each corner of the cloud and then not more than 12 feet in each direction. Depending on the height of the plenum, 1/2" EMT conduit can be used. The EMT ends are flattened and bent to facilitate attachment to the structure and the suspension system. Install the post first, and then connect the diagonals to the lower end of the strut just above the suspension system bulb.

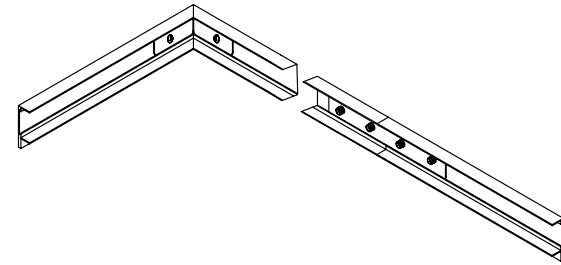

(Fig 12)

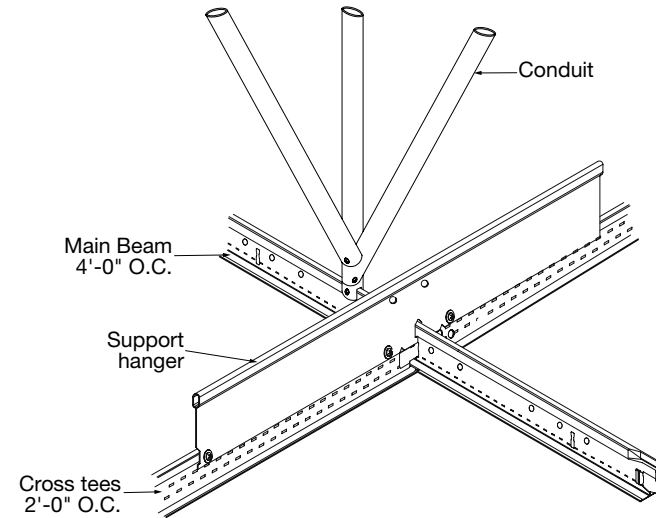

(Fig 13)

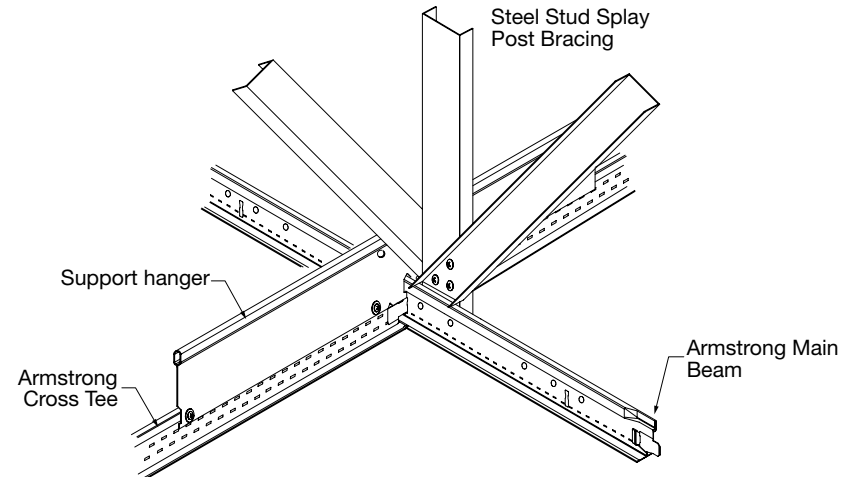

(Fig 14)

9.2.4 Restraint for a cloud is rigid diagonal bracing to the structure and since clouds are not attached to two walls, they must have restraints. In addition to building code requirements, there is a particular installation benefit for a contractor to restrain a ceiling that does not run wall-to-wall. A restrained ceiling is easier to keep straight and square. Some contractors will initially opt to skip this step in an attempt to save money. However, it is not advisable to do so because rework to fix alignment issues can add more labor costs than if the bracing would have been done at the onset. Typical restraint for a floating ceiling takes the form of rigid diagonal braces that extend from the suspension system members to the overhead structure. Sufficient restraint points must be used to meet the force values required by the code and to prevent movement in all directions. Additionally, the strength of the bracing members also must be matched to the anticipated applied forces.

9.2.5 Rigid bracing at all four corners meets the requirements of Seismic Design Categories D, E, and F for clouds up to 200 SF as long as:

- The bracing is based on the cloud area, weight, and plenum depth
- The bracing is designed by the project engineer

Keep in mind that hanger placement is determined by the length of the cantilevered component. It is not a line of sight issue. Also, a cloud will require the same bracing and restraint with or without sprinklers.

9.3 Distance between a Cloud and Wall or Adjacent Cloud

There is no minimum required as long as clouds are restrained to meet the Seismic Design Category.

10. INSTALL CEILING PANELS

10.1 IMPORTANT NOTE: Ultima® and Optima® Vector® panels should be installed with Seismic Hold Down Clips (item 442) in all projects designated as Seismic Design Category D, E, or F. Refer to Seismic Installations and Armstrong Ceiling Systems Guide (CS-4141) for guidance on the correct application of these clips.

10.2 Clean and align Axiom® components and install ceiling panels to complete the assembly.

MORE INFORMATION

For more information, or for an Armstrong Ceilings representative, call 1 877 276 7876.

For complete technical information, detail drawings, CAD design assistance, installation information, and many other technical services, call TechLine customer support at 1 877 276 7876 or FAX 1 800 572 TECH.

Inspiring Great Spaces® is a registered trademark of AFI Licensing LLC; XAL® is a registered trademark of XAL Inc.; Backlight® srl is a registered trademark of BACKLIGHT srl; All other trademarks used herein are the property of AWI Licensing LLC and/or its affiliates.

© 2020 AWI Licensing Company Printed in the United States of America

BPLA-297247-820

