

# INFUSIONS™ Resilient Partitions

## Assembly and Installation Instructions

### 1. GENERAL

Infusions™ Resilient partitions feature a selection of finishes in translucent 24 x 96 x 1/4" PETG material. Partitions can be suspended individually or joined together side-to-side.

Infusions Resilient partitions should be stored at room temperature in a dry environment that is not exposed to direct sunlight or heat. Partitions should be stored horizontally (flat), as delivered, to prevent warpage. Due to possibilities of expansion or contraction, allow material to come to room temperature prior to installing.

### 2. DESIGN AND INSTALLATION LIMITATIONS

Infusions Resilient partition panels should always be installed in accordance with all applicable building codes and regulations.

Do not allow panel to get wet.

Panels are susceptible to "wicking." If the panel is placed in a damp or wet area, water may "wick" up through the panel.

Infusions Resilient partition panels are not approved for exterior application.

PETG panels can be damaged by exposure to high temperatures. Panel temperature should not be permitted to exceed 100° F. Follow these guidelines for minimum distance from standard light sources:

Lamp Type	Label Wattage	Minimum Distance
Halogen FL XL PAR 30	60	14"
Incandescent Bulb	120	15"
Quartz Halogen Work Light	500	23"

### 3. FIRE PERFORMANCE

Infusions Resilient partitions have been tested according to NFPA 286 and are equivalent to Class A Interior Finish as defined by the International Building Code.

Contact TechLine at 1 877 276-7876 for specific US and Canadian fire performance data.

### 4. PANEL KIT CONTENTS

Each kit includes a panel, a Partitions hanging kit, and a floor attachment kit.

#### 4.1 Partitions Hanging Kit (Item 5825) Contents (Fig 1):

- (2) Mounting Plate
- (2) Universal Joint Module
- (2) Hollow Stud – inserted in UJM above
- (2) Cable Coupler
- (2) Mounting Plate w/ Screw Holes
- (2) 1/16" x 180" SS Cable – barrel end terminal 1 end
- (2) Adjustable Clevis
- (2) Dog Point Set Screws
- (1) Allen Wrench

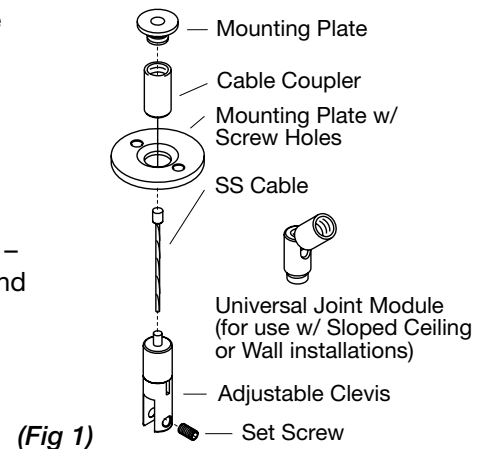

## 4.2 Floor Attachment Kit (Item 5828) Contents (Fig 2):

- (2) Adjustable Clevis
- (2) Dog Point Set Screws
- (2) Nylon Tipped Set Screws
- (2) 1/16" x 48" SS Cable – barrel end terminal 1 end
- (2) Mounting Plate w/ Screw Holes
- (2) Cable Coupler
- (2) Mounting Plate
- (1) Allen Wrench

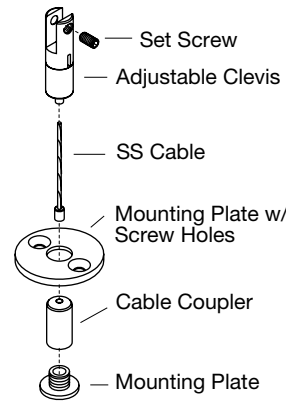

(Fig 2)

## 5. INSTALLING PANELS

Use fasteners that are appropriate for the selected substrate that will support at least 100 pounds each.

### 5.1 Panel Layout

Determine the exact panel location for installation. The suspension cables are located 3" in from each side of the panel. Suspension cables must be vertical. Use a plumb bob or laser to locate the structure and floor suspension points. When installing multiple panels, accurate layout is important for final panel alignment.

### 5.2 Attach the Upper Mounting Plate to Structure

There are several options for attaching the mounting plate to structure. Use the best option for your installation (Fig 3).

#### 5.2.1 Direct-Attach to Structure

Use the appropriate fastener up through the center of the mounting plate to secure to structure. The head of the fastener must be less than 3/8". This method does not use the mounting plate with screw holes (Fig 4).

**NOTE:** The mounting plate has 1/4"-20 NC internal threads that may be used to attach to structure or support.

#### 5.2.2 Mounting Plate with Two Screw Holes

This option is used for: a larger mounting plate visual; when two fasteners are needed to carry the load; or wall installations.

Insert the cable into the cable coupler, next thread the cable coupler onto the Mounting plate and tighten. Feed this cable assembly through the mounting plate with two holes. Secure the Mounting plate with two holes to structure using the appropriate fastener (Fig 5).

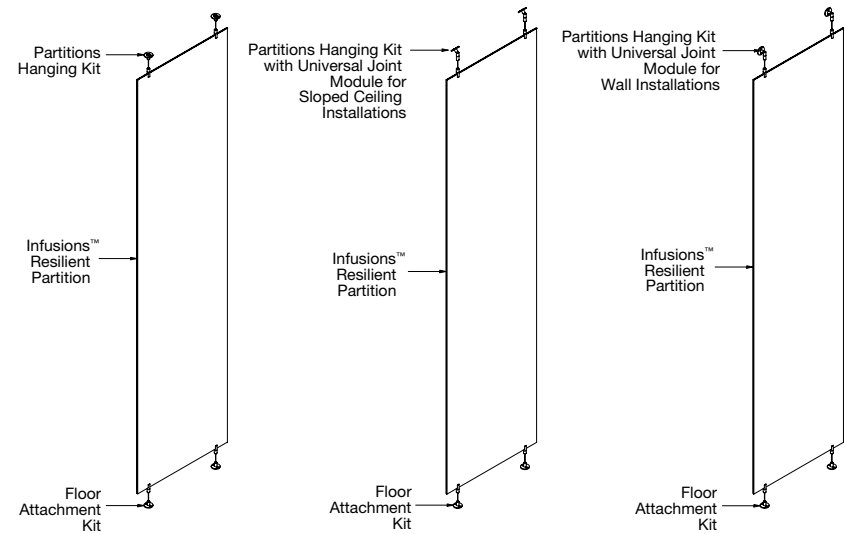

(Fig 3)

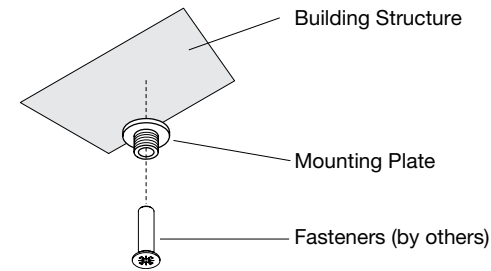

(Fig 4)

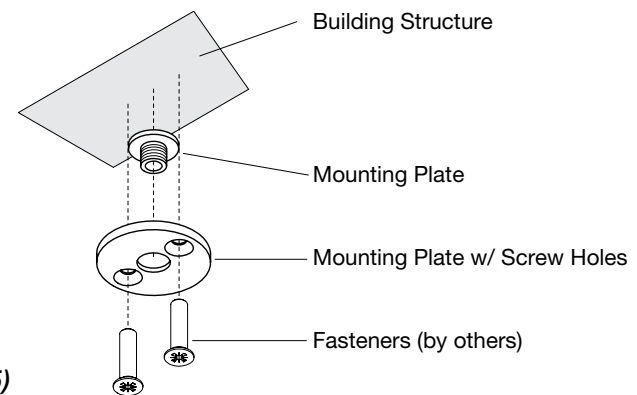

(Fig 5)

### 5.2.3 Below or Through an Existing Ceiling

It is recommended that the mounting plate be installed directly above or below an existing ceiling so the suspension cable does not cut the ceiling panels. Use bracing to rigid structure to fasten the partition panel mounting plate at the desired location. When the mounting plate is above the ceiling panel use an escutcheon plate (7006 Escutcheon kit) on the cable at the ceiling surface (*Fig 6*).

### 5.3 Attach Cables to the Mounting Plate

Feed the cable end through the hole in the cable coupler until the ball on the end is captured in the coupler. Next, thread the coupler onto the mounting plate and tighten. Do not cut off the factory end of the cable until the panel is hung.

### 5.4 Attach the Adjustable Clevis to the Panel

You are now ready to attach the hardware to the panel. Peel back and remove the protective film from the panel. Back out the dog point set screw in the adjustable clevis. Place the adjustable clevis over the panel so the hole in the connector (with the dog point set screw) lines up with the hole in the panel. Turn the dog point set screw into the hole in the panel (*Fig 7*). Do not over-tighten! Run the dog point set screw into the hole in the panel until it just touches the other leg of the connector. Attach all four adjustable clevis to the partition panel.

**NOTE:** Attach all hardware with the dog point set screw on the same side of the panel.

### 5.5 Hanging the Infusions™ Resilient Partition Panel

When the cables are suspended from the structure, and the adjustable clevis is attached to the panel, you are ready to hang the partition panel.

Feed the cable end into the nipple on the adjustable clevis and push it through until the end comes out the side. Repeat this process for the second cable. Take the weight off of the cables and pull the cables through the adjustable clevis while raising the panel until the panel is at the desired height. If you raise the panel too far, take the weight off the cable, depress the nipple on the adjustable clevis and let the cable slip back through the connector.

### 5.6 Attach the Lower Mounting Plate to the Floor

The Floor Attachment Kit must be used regardless of the seismic design category. Use a plumb bob or laser to determine the exact location of the lower mounting plate. Follow step 5.2.1 or 5.2.2 to attach the mounting plate to the floor. Attach cable and cable coupler to mounting plate.

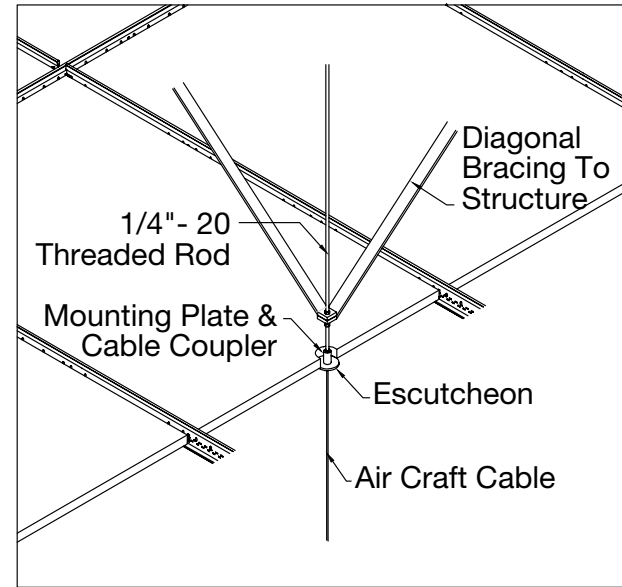

(Fig 6)

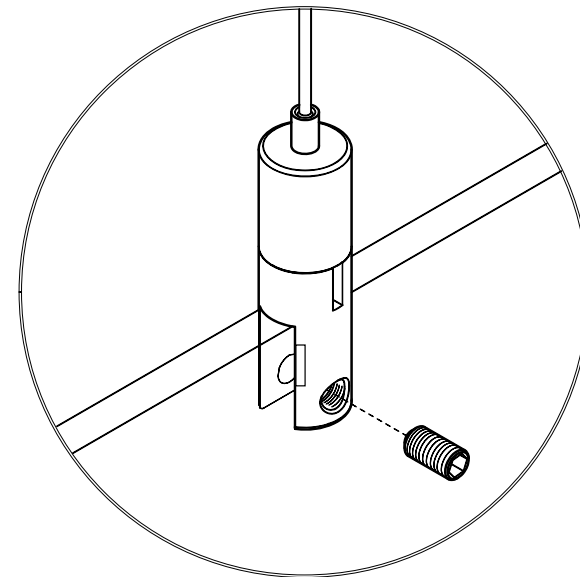

(Fig 7)

Feed the cable end into the nipple on the bottom adjustable clevis and push it through until the end comes out the side. Repeat this process for the second cable. Pull the cable until it is snug and prevents the panel from swinging.

Make final adjustments for panel alignment and then cut off excess cable at all four adjustable clevis connectors.

### 5.7 Side-to-Side Joined Partitions

Use the panel Joining Kit (Item 5827) for panel alignment when multiple panels are suspended side-to-side (*Fig 8*).

The kit consists of three clamps that will space the panel 5/8" apart. When planning the layout for joined panels, the on center spacing will be 24-5/8". Three clamps are spaced between adjoining panels, typically 3" from top, mid-panel, and 3" from the bottom. The clamps have two set screws with nylon tips.

Position clamps on one panel and tighten the set screw until the nylon tip is snug against the panel. Fit the adjoining panel into the clamps, align the panels and snug the set screws. These clamps are for panel alignment and do not provide suspension support.

### 5.8 Sloped Ceiling Installation

Use the universal joint module to attach the cable coupler to the mounting plate for sloped ceilings (*Fig 9*). This is required because the cable coupler must be in line with the cable and adjustable clevis.

Determine the location of the mounting plate. Follow step 5.2.1 or 5.2.2 to securely attach the mounting plate to structure. Next, thread the universal joint module to the mounting plate and tighten. The cable coupler and cable can now be threaded to the brass insert of the universal joint module. Follow section 5.5 to install the panels.

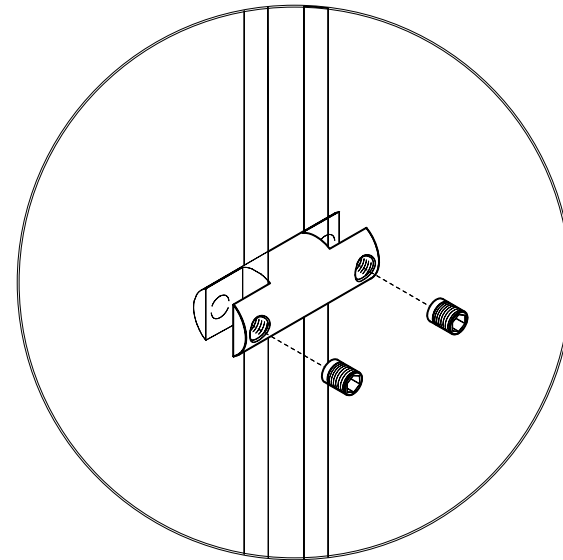

(Fig 8)

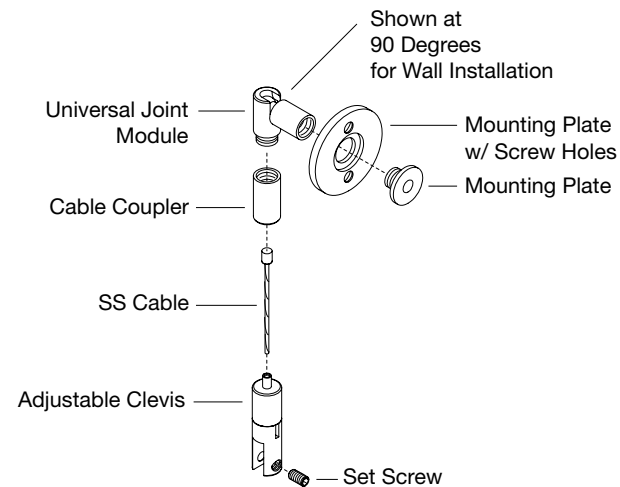

(Fig 9)

## 5.9 Wall Installation

Panels can be suspended from a wall using the universal joint module (*Fig 10*).

Determine the location of the mounting plate. Due to the lateral load on the mounting plate, we recommend using the mounting plate with two screw holes (section 5.2.2) to securely attach the mounting plate to structure. Next, thread the universal joint module to the mounting plate and tighten. The cable coupler and cable can now be threaded to the brass insert of the universal joint module (*Fig 11*). Follow section 5.5 to install the panels.

## 6. GENERAL CLEANING RECOMMENDATIONS

Panels should be handled with clean gloves/hands to avoid fingerprints. Lightly dust with a duster or soft, clean cloth first. Keep the cleaning cloth free of grit.

Avoid wiping the panel surfaces with abrasive compounds of any type.

Static charges that may build up after removing protective masking can be removed by wiping the sheet with a cloth dampened with water.

**CAUTION: Do not allow panel edges to get wet when cleaning the panel surface. This would damage the panel and void the product warranty.**

## 7. CUTTING AND DRILLING RECOMMENDATIONS

**7.1** Infusions™ Resilient partition panels can be fabricated with most tools used for machining plastics, wood, or metal.

**7.2** Since engineered resins are poor heat conductors, the heat generated by machining operations must be absorbed by the tool or carried away by compressed air.

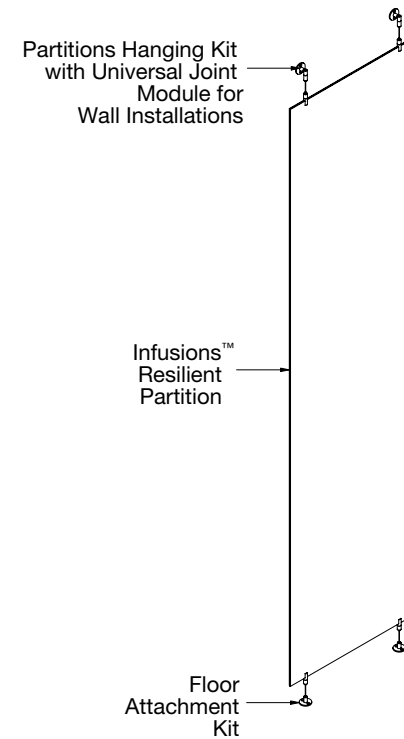

(Fig 10)

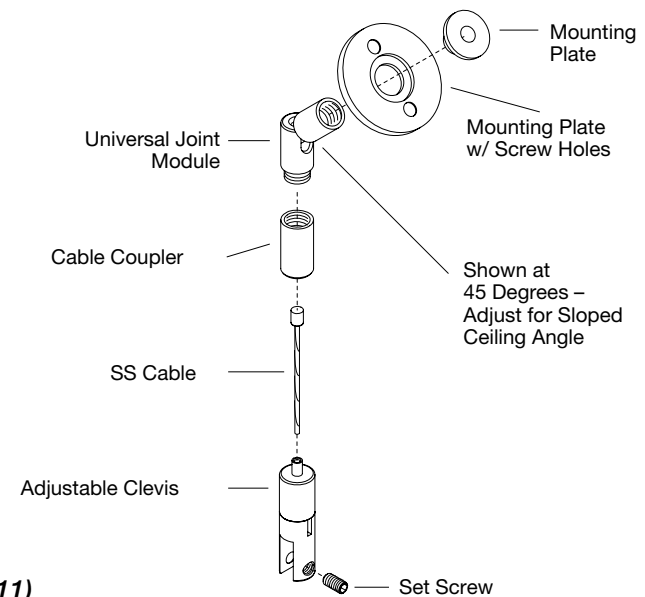

(Fig 11)

### 7.3 Cutting Recommendations

- Leave the original masking on the sheet during cutting operations.
- Practice on pieces of scrap before cutting actual panel.
- Use sharp, clean blades and bits.
- Use slow, consistent feed rate.
- Hold or clamp the panel firmly while cutting to minimize vibration.
- Use compressed air to minimize heat buildup.
- Feed against the rotation of the blade or tool.
- Do not scribe-break the panel.
- The following saw types, commonly used for wood or metal, should be used for cutting Infusions™ Resilient partition panels: circular saws, band saws, saber saws, or jigsaws. A circular saw is preferred to a band saw for straight cuts even though it tends to generate more heat. Make sure to minimize the heat by using compressed air or a coolant.
- Only cut the panel in the width direction. Do not cut the panel in the length direction (*Fig 12*).
- It is recommended to install the cut edge of the panel closest to the floor.

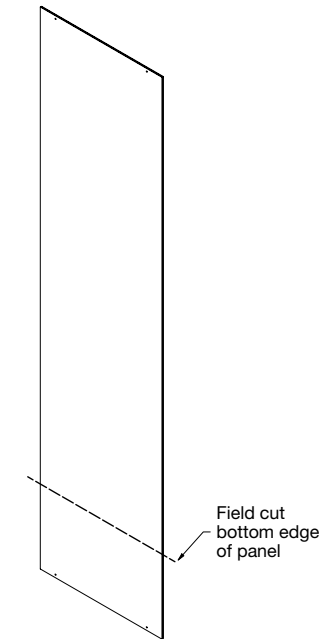

(Fig 12)

### 7.4 Drilling Recommendations

- Drills designed for plastics are widely available.
- Drills should be backed out often to free chips.
- Hold or clamp the panel firmly while drilling to prevent it from cracking or moving.
- Follow the hole relocation details in (*Fig 13*) to drill the new holes once a panel has been cut. There are two .187" diameter holes located .53" from the bottom edge of the panel and 3" in from each outer panel edge. A 3/16" bit size is recommended.
- Holes for fasteners should not be drilled closer than 2x the thickness of the panel.

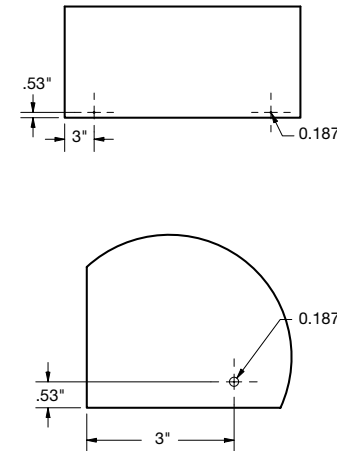

(Fig 13)

### MORE INFORMATION

For more information, or for an Armstrong Ceilings representative, call 1 877 276 7876.

For complete technical information, detail drawings, CAD design assistance, installation information, and many other technical services, call TechLine customer support at 1 877 276 7876 or FAX 1 800 572 TECH.

Inspiring Great Spaces® is a trademark of AFI Licensing LLC;

All other trademarks used herein are the property of AWI Licensing LLC and/or its affiliates.

© 2020 AWI Licensing Company Printed in the United States of America