

AXIOM® Knife Edge® Perimeter Trim

Assembly and Installation Instructions

1. GENERAL

1.1 Description

Axiom® Knife Edge® Perimeter Trim is designed for use with any of the Armstrong® suspension systems. Field fabrication is limited to component assembly, straight cuts, and minor adjustments to accommodate differences between design dimensions and actual field conditions.

AXKE2STR and AXKE5STR are designed for use with acoustical lay-in or tegular panels and drywall. AXKEV2STR is for use with full panel installations of the Vector® family of products.

These instructions are divided into sections detailing material delivery and identification, component assembly, AXKE2STR and AXKE5STR installation, AXKEV2STR installation, and final detailing. Please carefully review all appropriate sections before proceeding with installation.

2. MATERIAL DELIVERY AND IDENTIFICATION

2.1 Delivery

Exercise appropriate care to protect the finished surfaces of the channel trim.

2.2 Review

Review the packing slip to ensure that the complete order has been delivered to the site.

3. COMPONENT ASSEMBLY

3.1 Splice Plates and Alignment Clip

Steel splice plates are used to align and secure all joints between sections of Axiom Knife Edge trim. Alignment clips serve to position the outer edges of the trim sections. Each joint will require one splice plate and one alignment clip. Splice plates are secured to the trim sections using factory-installed setscrews. Where desired, it may be beneficial to caulk or tape the backside of the vertical joints to prevent light transmission.

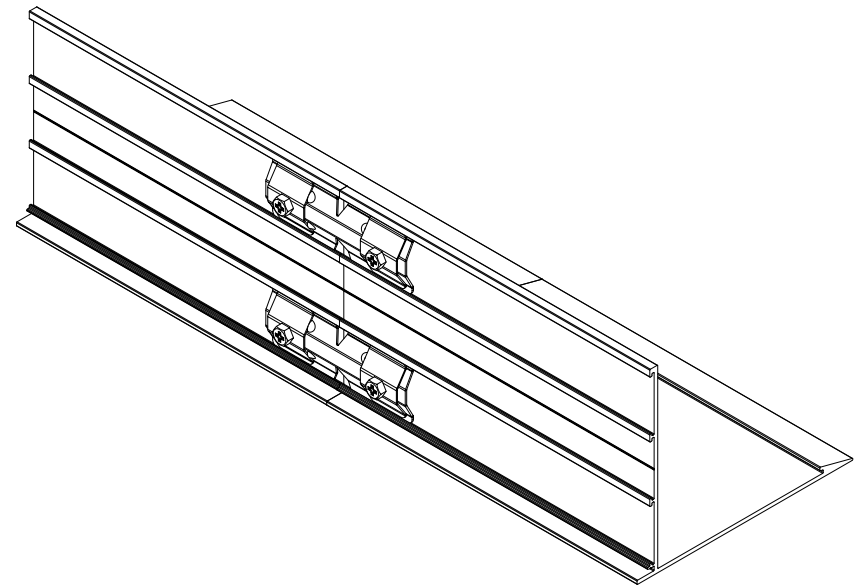

AXKE5STR – 5" Axiom® Knife Edge® Trim with Splices

Typical Procedure

3.1.1 Position the splice plate (AXSPLICE2) so that it is roughly centered on the joint between trim sections.

3.1.2 Tighten the two setscrews to secure the splice to the trim.

3.1.3 Install the Alignment Clip (AXKEALIGN) by inserting the flat end into the groove located behind the leading edge of the trim. Press the back end of the clip down to lock in position. *(Fig 1)*

3.2 Corner Assembly

Factory-assembled inside and outside corners come pre-mitered, bonded, and finished. The legs of the corner measure 12" along the edge of the flange that supports the suspension system. Corner sections are installed using Splice Plates (AXSPLICE2) and Alignment Clips (AXKEALIGN) at each joint.

3.3 T-Bar Connector Clips – Suspended Ceilings

T-Bar Connector Clips are used to attach the Axiom Knife Edge trim to the supporting suspension system members. These two-piece or three-piece clips are supplied as an assembled unit with the steel locking screw factory installed. One clip is required at each location where the suspension system intersects the channel trim.

There are three versions of the T-Bar connector clip:

The AXTBC is used in installations where the grid will rest flush on the Axiom® flange (e.g. lay-in, and full size tegular panels) or need to be raised 1/4" above the Axiom flange (e.g. cut tegular panels, Silhouette®, or Interlude® grid). *(Fig 2)*

The AXVTBC is used in installations where the grid will need to be raised 3/8" or 1/2" (cut Vector® panels). The AXVTBC must be requested at the time of order in lieu of the AXTBC clips.

For 5" Axiom® Knife Edge® Trim only:

The ATC (Adjustable Trim Clip; item 7239) can be used in various installations to accommodate a range of grid offsets. This clip can be adjusted to install grid at 0" to 3-3/4" above the flange of the Axiom Trim at 1/8" increments. This adjustability enables 5" Axiom Knife Edge® Trim to be installed with a range of WoodWorks®, MetalWorks™, and other Architectural Specialties products. The ATC must be requested at the time of order in lieu of the AXTBC clips.

NOTE: For installation of T-Bar Connector Clips in drywall applications, refer to the Drywall Trim Section.

The suspension system does not require modification and must be installed following the standard WoodWorks® Linear Veneered panels instructions.

T-Bar Connector Clips are attached to the suspension system members using screws supplied by the installer. Framing screws (#6 x 7/16" or 1/2" lg.) are typical. Special conditions such as open cell installations may dictate the use of alternate methods of attachment.

See detail drawings *(Fig 6)* for alignment of the connector clip with the suspension system member.

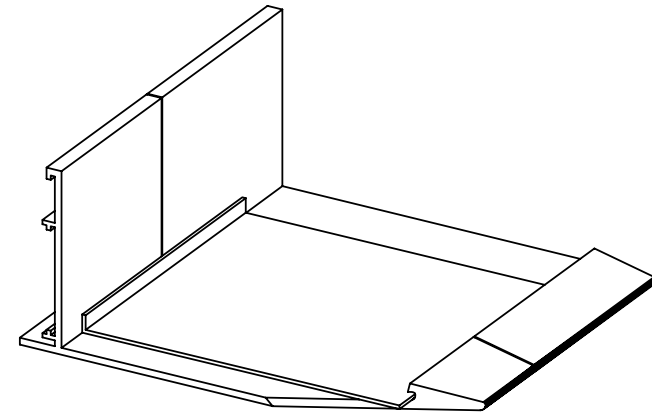

AXKEALIGN – Alignment Plate

(Fig 1)

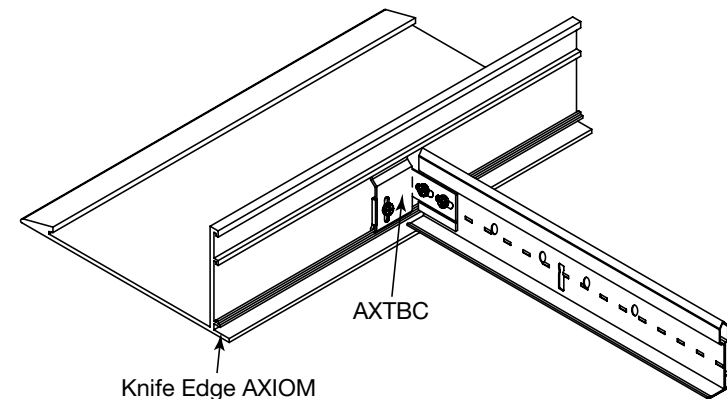

AXTBC – T-Bar Connector Clip

(Fig 2)

Typical procedure – Suspended Ceiling Installations

- 3.3.1 Cut suspension system to length
- 3.3.2 Attach clip to suspension system member
- 3.3.3 Engage clip in channel bosses and tighten locking screw

3.4 Drywall Trim

Drywall trim is used to finish the edges of gypsum panels that are applied to drywall suspension system finished with Axiom Knife Edge Trim. Axiom drywall trim sections are factory formed to fit into the groove inside Axiom Knife Edge Trim. **(Fig 3)**

Axiom drywall trim is set in place, then fastened using standard drywall screws applied through the taping flange of the trim into the drywall suspension system.

After installation, the trim is finished using standard drywall materials and techniques. Normally, the drywall and Axiom Knife Edge Trim is then painted to meet job requirements.

3.5 T-Bar Connector Clip Installation – Drywall

IMPORTANT NOTE: Use only the AXVTBC T-Bar Connector Clip for drywall applications. **(Fig 4)**

- 3.5.1 Cut the clip off 1/16" above the score line for application of 1/2" drywall. Cut 3/16" above the score line (halfway between the score line and the bottom of the screw slots) when using 5/8" drywall.
- 3.5.2 Attach the modified AXVTBC clips to the drywall suspension system using two framing screws for each clip.
- 3.5.3 Install the Axiom Knife Edge trim and tighten clamping screws.

Typical Procedure – Drywall Applications

- 3.5.4 Install drywall suspension system and Axiom Knife Edge trim
- 3.5.5 Attach drywall to the system
- 3.5.6 Install Axiom drywall trim
- 3.5.7 When installing the drywall provide backing so that molding may be attached with #6 drywall screws 16" O.C. for horizontal applications.
- 3.5.8 **Prior** to taping, the attachment flanges should be cleaned using a non-abrasive cleaner and soft rag. When veneer plaster is specified, the flanges must be treated with a bonding agent.
- 3.5.9 Make sure the tape does not overlap the edge of the reveal and an 8" wide trowel is used to apply the final skim coat.
- 3.5.10 Fiberglass self adhesive drywall tape will cut taping time and help to avoid possible cracking.
- 3.5.11 Tape and finish drywall
- 3.5.12 Paint

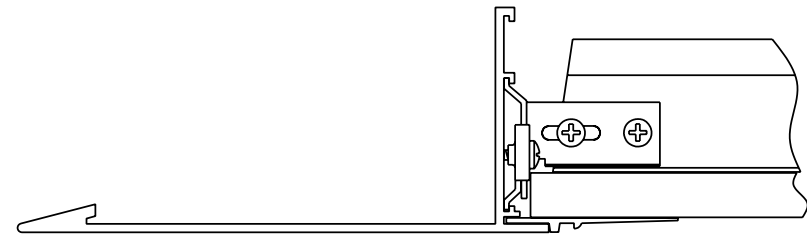

AXDWT in AXKE2STR – Axiom® Knife Edge® Trim with Drywall Bottom Trim

(Fig 3)

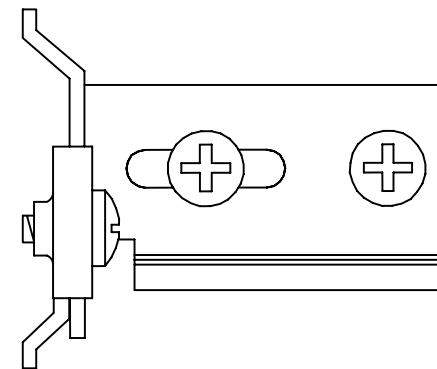

AXVTBC

(Fig 4)

3.6 Hold Down Clip for Metal Panels

3.6.1 Use the AXSPTHDC clip to hold the face of cut metal panels down on the flange of the Axiom trim.

3.6.2 One clip will be required for about every foot of cut panel edge.

3.6.3 Insert the top of the clip into the Axiom trim first, then press up on the clip and engage the lower end. (Fig 5)

4. GENERAL INSTALLATION PROCEDURES

4.1 Lay out and install the suspension system according to the reflected ceiling plan.

4.1.1 Plan your suspension system layout to maximize the length of cross tees that will support Axiom® Knife Edge® components.

4.1.2 Suspend the system using minimum #12 gauge steel wire spaced no more than four feet O.C. along the main beams. Additional wires may be required within eight inches of the cut ends of all suspension system components in areas where severe seismic activity is possible.

4.2 Brace and square the suspension system.

4.2.1 Bracing will greatly increase the speed and accuracy of completing the remainder of the installation, and is highly recommended.

4.2.2 The suspension system can be braced diagonally to the structure above using either splayed wires or rigid bracing members such as angles or cold rolled channels. In either case, install bracing in the plane of both main beams and cross tees.

4.2.3 Squaring can be accomplished by temporarily clamping a rigid member (main beam or wall angle) diagonally across the topside of the suspension system to maintain 90° alignment of the main beams and cross tees.

4.2.4 An alternate method is to cut scrap suspension system components to fit diagonally into the ceiling module. When installed in pairs, these short braces are effective during layout and installation, and can be reinstalled on top of the ceiling panels to maintain alignment of the system.

4.2.5 For small installations, it may be preferable to assemble, mark, and cut the suspension system components on the floor, and then suspend and brace the suspension system.

4.3 Assemble and position the Axiom components on top of the suspension system.

4.3.1 Temporarily assemble the Axiom components resting on top of the suspension system. Check alignment and clamp the components in place.

4.3.2 Mark the location where the open side of the Axiom trim rests on the suspension system members. This mark will be used for initial alignment of the T-Bar Connector Clip. (Fig 6)

4.3.3 Make a second mark approximately 1/4" closer to the face of the Axiom trim. This second mark is where the suspension system members will be cut.

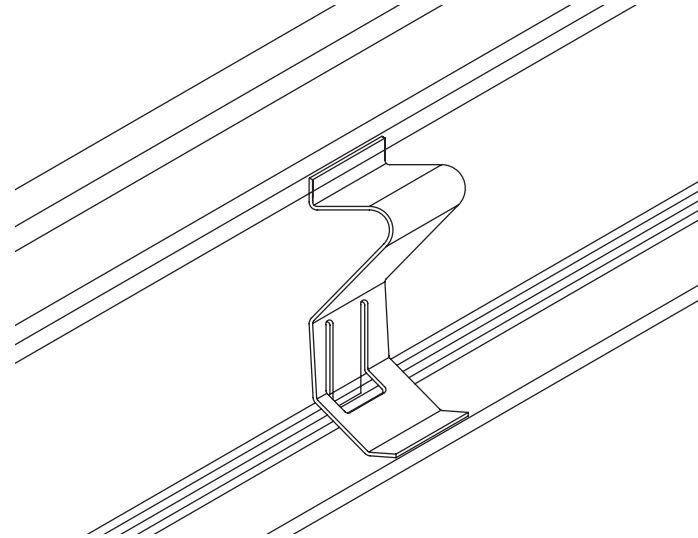

AXSPTHDC – Hold Down Clip

(Fig 5)

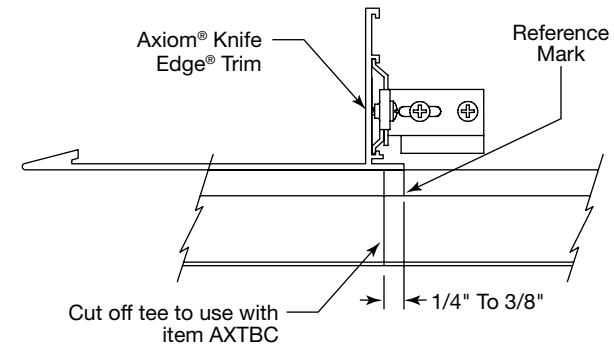

(Fig 6)

4.3.4 Remove the Axiom components and cut the suspension system members as marked.

4.3.5 Follow these guidelines for vertical location of the clips on the web of the suspension system members:

1. T-Bar suspension system will rest on the lower flange of the Axiom Trim (*Fig 7*)
2. Silhouette®, Interlude®, Sonata®, and Trimlok® (systems with a 5/16" shoulder height) and 5/8" concealed tile on Prelude® suspension systems (*Fig 8*)
3. MetalWorks™ Vector® (cut panels) and 3/4" concealed tile (*Fig 9*)
4. Ultima®, Optima®, and WoodWorks® Vector (cut panels) — use AXVTBC

4.3.6 Attach the clips by aligning the end of the elongated hole with the reference mark on the suspension system and inserting a standard framing screw into the center of the slot.

4.4 Install the Axiom Trim

4.4.1 Hang the sections of channel trim onto the suspension system by engaging the top ear of the connection clips under the boss of the channel trim. Slide the back plate downward to engage the lower boss on the trim and secure by tightening the locking screw.

4.4.2 Complete the installation of all channel trim sections. Install and secure the splices and alignment plates.

4.4.3 Make adjustments as necessary to properly align the complete installation. Insert a second framing screw in each of the connection clips.

4.5 Add additional hanger wires as required.

4.5.1 The manufacturer requires that Axiom systems and their supporting suspension systems be installed and supported in a manner that complies to all applicable codes and standards. Typically, this will require the use of #12 gauge galvanized, soft annealed steel wire or equivalent. Specification and approval of alternate materials should be by design professionals familiar with the project.

Installers should exercise care in the application of hangers to minimize the visual impact on the finished installation. Wire wraps should be tight and neat, and where appropriate, the wires may be painted to blend into the background as much as possible.

4.5.2 Main beams must be supported 4' O.C. or by calculation based on actual ceiling weight.

4.5.3 Cross tees located on each side of a joint in the channel trim and then at 4' centers must be supported by wires located no more than 12" from the perimeter trim.

4.5.4 For installations using Armstrong® WoodWorks® panels, you must have two hanger wires connected to Hanging Clips (AX2HGC) on each section of Axiom® Knife Edge® trim. One hanging clip and wire is required for each welded corner. (*Fig 10*)

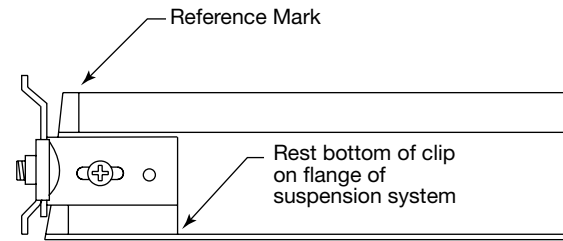

(Fig 7)

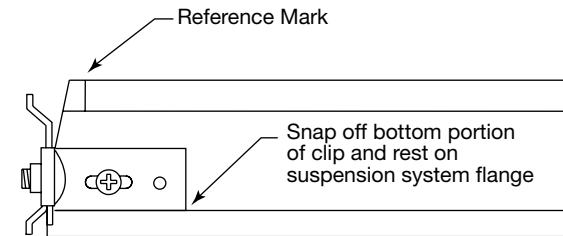

(Fig 8)

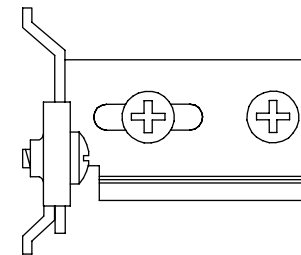

AX-V-TBC

(Fig 9)

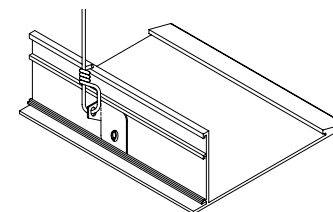

AX2HGC – Hanging Clip

(Fig 10)

5. INSTALL RESTRAINT/SEISMIC BRACING

5.1 Restraint for clouds installed on projects where anticipated seismic activity will be light (IBC seismic design categories A & B) can be accomplished by installing a pair of crossed cables 2' in from each edge of the assembly. These cables should attach to the support channels and be sloped no more than 45° from horizontal.

5.2 In areas where anticipated seismic activity will be moderate to severe, the crossed cables should be replaced with a bracing system more appropriate for the forces that will be encountered.

NOTE: Testing conducted at the Structural Engineering Earthquake Simulation Laboratory, located at the State University of New York – Buffalo campus, produced satisfactory results with rigid bracing fabricated from 1/2" EMT conduit.

The tested bracing system consisted of a vertical member extending from the support channel to the structure above near each corner of the cloud. These members were positioned at the main beam/support channel intersections closest to the corners of the assembly. Two additional members were fastened to the bottom of the vertical and extended to the structure at an angle not exceeding 45° from horizontal. These members were parallel to the sides of the cloud.

5.3 Restraint/bracing systems should be approved by the project design team and reviewed with the local building department.

6. INSTALL CEILING PANELS, TILE, OR DRYWALL

6.1 Cut and install tiles or panels using standard procedures for the specified products.

6.2 Treat exposed cut edges of ceiling panels as detailed in the project specifications.

7. AXIOM KNIFE EDGE TRIM FOR VECTOR®

7.1 Axiom Knife Edge Trim for Vector (*Fig 11*) is only appropriate for square or rectangular applications that feature all full-size panels.

7.2 Cut and install the suspension system to maintain precisely 23-1/16" between the outer edge of the 15/16" T-Bar suspension system and the inner edge of the Axiom trim.

7.3 The correct length for the Axiom trim, when measured along the inside edge, will be 15/16" less than the nominal dimension of the full panel installation.

EXAMPLE: The nominal dimension of a four panel wide cloud would be 96". The Axiom trim should be cut to 95-1/16" measured along the inside edge of the flange that supports the suspension system.

7.4 Use standard AXTBC clips to attach the trim to the suspension system.

7.5 Brace the suspension system to structure as required by local codes and to maintain straight and square alignment.

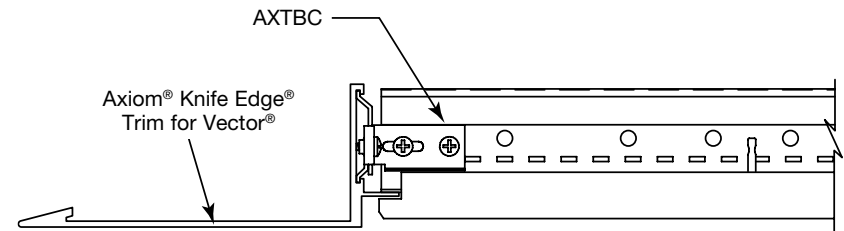

Axiom® Knife Edge® Trim for Vector®

(Fig 11)

8. AXIOM ANGLED KNIFE EDGE TRIM

8.1 Attaching to Suspension System

8.1.2 Refer to the reflected ceiling plan for the suspension system layout

8.1.3 Cut suspension system to length

8.1.4 The cross tee that intersects with the Axiom® Angled Knife Edge® Trim must be cut on an angle due to the knife edge profile

8.1.5 Use AXCCCLT45 to attach the trim to the suspension system

8.1.6 Brace the suspension system to structure as required by local codes and to maintain straight and square alignment

8.1.7 Use a pop rivet through the XL clip holes in the tee and the AXCCCLT45 clip to ensure a full tile connection

8.1.8 Drywall applications

Typical Procedure – Drywall Applications (Figs 12 & 13)

8.1.9 Install drywall suspension system and Axiom Angled Knife Edge Trim for drywall

8.1.10 Attach 5/8" drywall to the suspension system

8.1.11 Tape and finish drywall

8.1.12 Paint

Typical Procedure – ACOUSTIBuilt Applications (Fig 14)

8.1.13 Install drywall suspension system and Axiom Angled Knife Edge trim for ACOUSTIBuilt.

8.1.14 Attach 7/8" ACOUSTIBuilt panels and finish per standard ACOUSTIBuilt installation instructions

8.2 Corners for Axiom Angled Knife Edge Profiles

Axiom Angled Knife Edge corners can be ordered in for Acoustical, Drywall, and ACOUSTIBuilt trims. Pre-made factory-finished inside and outside corners are made to coordinate with the straight Axiom Angled sections. Each corner section is 12" by 12" square (dimension taken on the face of the extrusion).

NOTE: For Drywall and ACOUSTIBuilt installations, approximately 1/8" of material will need to be removed from the backside of the panel to provide clearance for the seam weld. This will ensure the panel remains flush with the butt taping flange at the corner.

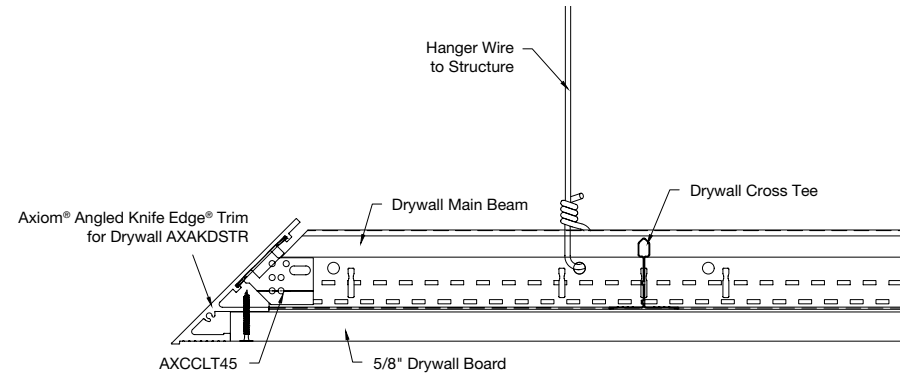
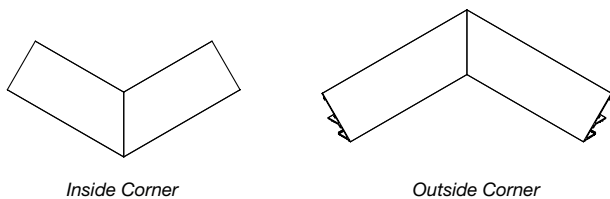

Axiom Angled Knife Edge Trim for Drywall Applications

(Fig 12)

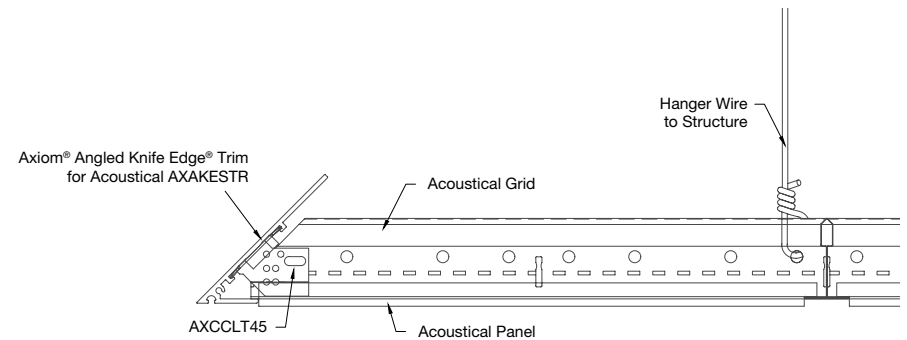

Axiom Angled Knife Edge Trim for Acoustical Applications

(Fig 13)

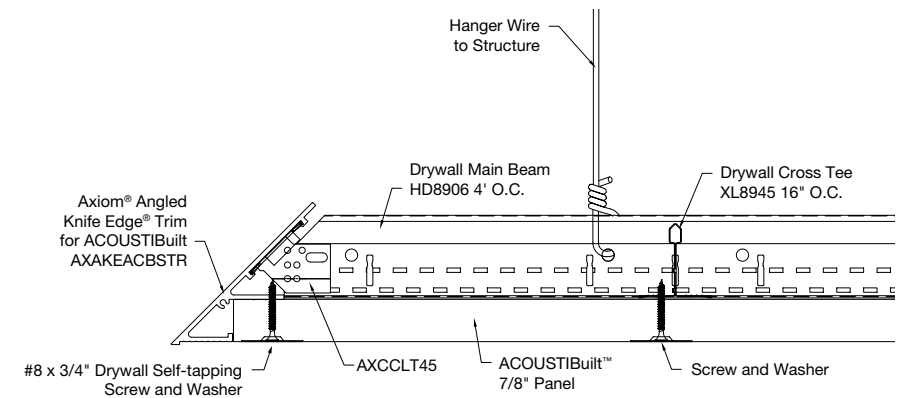

Axiom Angled Knife Edge Trim for ACOUSTIBuilt Applications

(Fig 14)

9. FINAL DETAILING

- 9.1 Check and adjust the alignment of Axiom components and ceiling panels
- 9.2 Clean exposed surfaces as required. Painted Axiom components may be wiped down with a mild household cleaner to remove fingerprints, oil, etc.
- 9.3 Touch up painted components as required
- 9.4 Axiom components with drywall are typically painted after assembly, taping, and finishing
- 9.5 For light cove applications, a white latex chalk or tape should be applied to the inside of all seams, if light leaks are apparent

MORE INFORMATION

For more information, or for an Armstrong Ceilings representative, call 1 877 276 7876.

For complete technical information, detail drawings, CAD design assistance, installation information, and many other technical services, call TechLine customer support at 1 877 276 7876 or FAX 1 800 572 TECH.

Inspiring Great Spaces® is a registered trademark of AFI Licensing LLC; All other trademarks used herein are the property of AWI Licensing LLC and/or its affiliates.

© 2020 AWI Licensing Company Printed in the United States of America