

AXIOM® Classic Trim

Assembly and Installation Instructions



1. GENERAL

1.1 Product Description

Axiom® Classic Trim is a perimeter trim system designed for use with a variety of Armstrong® suspension systems. Classic 2"-12" trim are available as standard items in 10' straight sections or as a custom fabricated assembly. Field fabrication for custom orders is limited to component assembly and minor adjustments to accommodate differences between design dimensions and actual field conditions. Each stick of 10' Axiom trim includes the appropriate amount of steel splice plates and T-Bar connector clips.

1.2 Cutting and Mitering

Standard items may require field cutting and mitering. These cuts are best made using an appropriately sized sliding compound miter saw fitted with a carbide-tipped blade designed for cutting non-ferrous metals.

NOTE: Formations™ Acoustical Clouds with Axiom® perimeter trim is not included in these instructions, but can be found in separate documents located on the technical information portion of the Armstrong website.

These instructions are divided into four sections detailing material delivery and identification, component assembly, suspended applications, and direct applied applications. Please carefully review all appropriate sections before proceeding with installation.

2. MATERIAL DELIVERY AND IDENTIFICATION

Custom Orders

Axiom components and hardware are delivered to the job site in custom designed packaging. Locate the shop drawings and packing slip, typically packaged with the hardware, and use these as a guide to identify components as they are carefully removed from the packaging material.

Exercise appropriate care to protect the finished surfaces of the channel trim.

Each length of channel trim is marked on the inside surface, near one end. These identification marks are keyed to the shop drawings to indicate the exact location of each section in the finished assembly.

Review the shop drawings and packing slip to ensure that the complete order has been delivered to the site and to familiarize you with the layout of the installation.

All curved orders for Axiom® trim are shipped with full-sized paper template drawings. Lay your curved material on the template to make sure the curve on the template matches the Axiom product.

3. COMPONENT ASSEMBLY

3.1 Splice Plates

Steel splice plates are used to align and secure joints between sections of channel trim. Each joint in the 2" section height will require one splice plate; 4", 6", and 8" sections require two splice plates at each joint; 10" section requires three splice plates; 12" and 14" profiles accept four plates; and the 16" high profile accepts five plates.

(Fig 1)

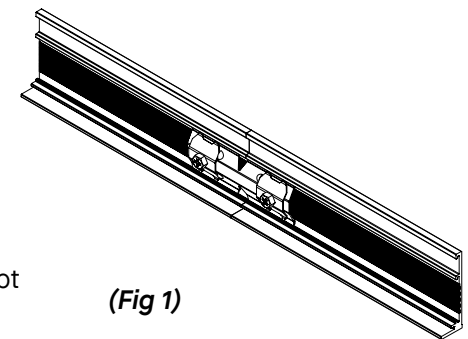

(Fig 1)

3.2 Factory-mitered Corners

FastShip™ inside and outside corners are factory-mitered sections of trim that measure 12" along the edge of the flange that supports the suspension system. The unmitered ends are attached to the straight sections of Axiom trim using the AXSPLICE2 (two screw) splice plates. AXSPLICE plates for mitered intersections are shipped flat and must be hand bent as required for mitered intersections. The mitered ends are joined using the AXSPLICE (two screw) splice plates. **(Fig 2)**

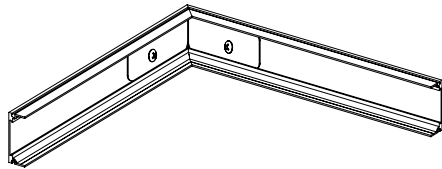

(Fig 2)

90° Corner with Splice Plate

Outside corner posts ship pre-assembled with the splice plate already built into the product. The ends are attached to the straight sections of Axiom trim using the AXSPLICE (two screw) splice plates that are built into the product. **(Figs 3 & 4)**

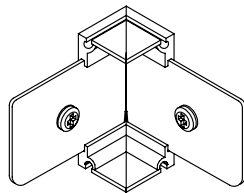

Outside Corner Post

(Fig 3)

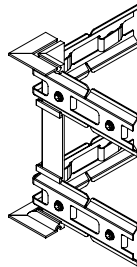

Inside Corner Post

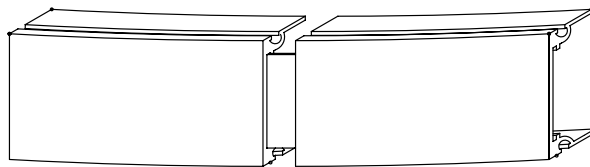

Insert splice plate in joint and close to about 1/2"

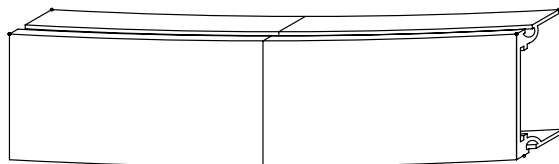

(Fig 4)

Close joint and tighten setscrews

Splice plates are secured to the trim sections using factory-installed setscrews.

Caution For AXSPLICE and AX4SPLICEB: Do not overtighten these screws. Apply only enough force to lock the components together. Overtightening the screws can deform the exposed face of the channel trim.

Typical procedure

1. Insert splices into channel trim bosses
2. Close the joint
3. Tighten screws

3.3 T-Bar Connector Clips

T-Bar connector clips are used to attach the channel trim to the supporting suspension system members. These two-piece or three-piece steel clips are supplied as an assembled unit with the steel locking screw factory installed. One clip is required at each location where the suspension system intersects the channel trim. **(Fig 5)**

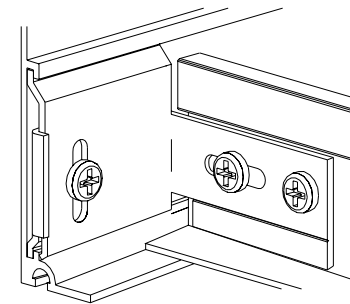

(Fig 5)

There are three versions of the T-Bar connector clip:

The AXTBC is used in installations where the grid will rest flush on the Axiom® flange (e.g. drywall, lay-in, full size Vector® and tegular panels) or need to be raised 1/4" (e.g. cut tegular panels, Silhouette® grid).

The AXVTBC is used in installations where the grid will need to be raised 3/8" or 1/2" (cut Vector panels). The AXVTBC must be requested at the time of order in lieu of the AXTBC clips. Please see Section 4 of this guide and the Axiom Classic Perimeter Trim Assembly Quick Reference Guide BPLA-295829 for additional interface details.

The ATC (Adjustable Trim Clip; item 7239) can be used in various installations to accommodate a range of grid offsets. This clip can be adjusted to install grid at 0" to 3-3/4" above the flange of the Axiom at 1/8" increments. This adjustability enables Axiom to be installed with a range of WoodWorks®, MetalWorks™, and other Architectural Specialties products. It is recommended that 6" Axiom Classic or taller be used to enable the full range of adjustment. If 4" is used the

adjustability is limited to 1-1/4" and the ATC is not compatible with 2" Axiom.

T-Bar connector clips are attached to the suspension system members using screws supplied by the installer. Framing screws (#6 x 7/16" or 1/2" lg.) are typical. Special conditions such as open cell installations may dictate the use of alternate methods of attachment.

See detail drawings for alignment of the connector clip with the suspension system member.

Typical procedure

1. Cut suspension system to length
2. Attach clip to suspension system member
3. Engage clip in channel bosses and tighten locking screw

3.4 Axiom Alignment Clips

Axiom Alignment Clips, AXAC, are used to align suspension system members that extend beyond the lower edge of the trim. These clips should not be used in the load path for any application. These aluminum clips are supplied with a factory-installed screw that locks the clip in position and are ordered separately. (Fig 6)

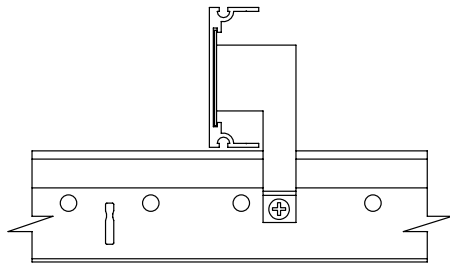

(Fig 6)

The clip is secured to the web of the suspension system members using a standard framing screw supplied by the installer. One clip is required at each suspension system/channel intersection.

Typical procedure

1. Rotate hanging clips into the channel trim bosses
2. Tighten clamping screw
3. Install framing screw to attach clip to suspension system

3.5 Direct Load Hanging Clips

Direct Load Hanging Clips, AX2HGC, are used when suspension wires must be attached directly to the trim sections. Typical installations have the wires attached to the suspension system and it supports the Axiom® trim. The weight of the 10", 12", 14", and 16" Axiom trim necessitates that they be supported directly to structure. (Fig 7)

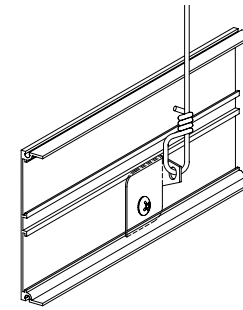

(Fig 7)

Typical procedure

1. Rotate hanging clips into the channel trim bosses
2. Tighten clamping screw
3. Attach hanger wire

3.6 Drywall Trim

Drywall trim is used to finish the edges of 5/8" drywall that are applied to the bottom surface of an Axiom installation. Drywall trim sections can be factory formed to match the contour of the Axiom channels to which they are applied. These components are keyed to the shop drawings to identify the location of each piece in the assembly. (Figs 8 & 9)

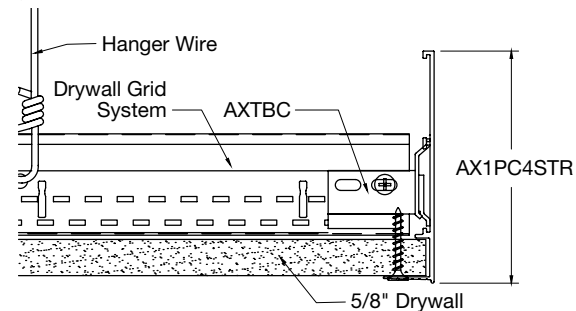

(Fig 8)

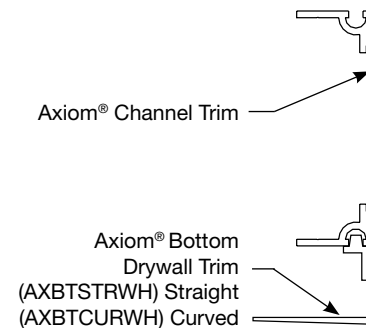

(Fig 9)

Drywall trim is fastened using standard drywall screws applied through the tapping flange of the trim into the drywall suspension system. After installation, the trim is finished using standard drywall materials and techniques. Normally, the drywall and Axiom trim is then painted to meet job requirements.

Typical procedure

1. Install drywall suspension system and Axiom channel trim
2. Attach 5/8" drywall to the system
3. Install Axiom drywall trim
4. Tape and finish drywall
5. Paint

Tapable Flange Installation

1. Install the moldings after the gypsum board is mounted in place.
2. Provide backing so that the moldings may be attached with #6 drywall screws 16" O.C. for horizontal applications.
3. Prior to taping, the attachment flanges should be cleaned using a non-abrasive cleaner and soft rag. When veneer plaster is specified, the flanges must be treated with a bonding agent.
4. Be sure the tape does not overlap the edge of the reveal and an 8" wide trowel is used to apply the final skim coat.

NOTE: Fiberglass self-adhesive drywall tape will reduce taping time and help avoid possible cracking.

3.7 Metal Panel Hold Down Clips

Metal panel hold down clips are used to secure the cut edges of metal ceilings at the Axiom® trim. Insert one clip for every foot of perimeter, or as needed, to maintain contact between the panel edge and the flange of the trim. These clips are ordered separately.

Insert the top of the clip into the channel first. Press up to compress the clip and insert the bottom leg into the channel. **(Fig 10)**

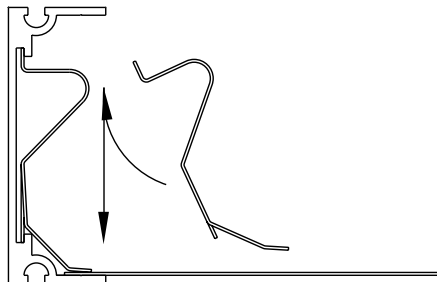

(Fig 10)

3.8 Suspended Applications

Suspended applications of Axiom trim are those in which the Axiom perimeter trim and the suspension system that supports it are installed in a manner that creates a space between the Axiom trim and the structure above and surrounding objects. These installations are often referred to as "clouds" and may be as simple as a square or rectangle of free-floating ceiling, or as complex as a free-form shape or symbol. Suspended Axiom applications may be purely aesthetic, or may be used to conceal overhead services or indirect lighting.

Typical procedure

1. Lay out and install the suspension systems according to the reflected ceiling plan.

- a. Plan your suspension system layout to maximize the length of cross tees that will support Axiom components.
- b. Some of these cross tees will have to have hanger wires attached to them. Longer cross tees will, in some cases, allow the wires to be located further away from the Axiom trim and, therefore, be less visible.

2. Brace and square the suspension system.

- a. Although not absolutely necessary, this step will greatly increase the speed and accuracy of completing the remainder of the installation, and is highly recommended.
- b. The suspension system can be braced diagonally to the structure above using either splayed wires, or rigid bracing members such as angles or "C" channels. In either case, install bracing in the plane of both main beams and cross tees.
- c. Squaring can be accomplished by temporarily clamping a rigid member (main beam or wall angle) diagonally across the topside of the suspension system to maintain 90° alignment of the main beams and cross tees.
- d. An alternate method is to cut scrap suspension system components to fit diagonally into the ceiling module. When installed in pairs, these short braces are effective during layout and installation, and can be reinstalled on top of the ceiling panels to maintain alignment of the system.
- e. For small installations, it may be preferable to assemble, mark, and cut the suspension system components on the floor, and then suspend and brace the suspension system.

3. Assemble and position the Axiom® components on top of the suspension system.

- a. Temporarily assemble the Axiom components resting on top of the suspension system. Check alignment and clamp the components in place.
- b. Mark the location where the open side of the Axiom channel trim rests on the suspension system members. This mark will be used for initial alignment of the T-Bar connector clip. **(Fig 11)**

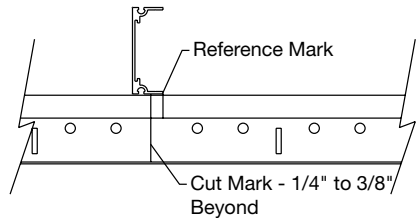

(Fig 11)

- c. Make a second mark 1/4" to 3/8" closer to the face of the Axiom channel trim. This second mark is where the suspension system members will be cut. The 3/8" dimension is the maximum length that the suspension system member can extend into the channel trim. Use of the 1/4" dimension allows more adjustment during final assembly.

4. Attach the T-Bar connector clips.

- a. Remove the Axiom components and cut the suspension system members as marked.
- b. Follow these guidelines for vertical location of the clips on the web of the suspension system members:
 - b.1. T-Bar suspension system that will rest on the lower flange of the Axiom trim – use AXTBC. **(Fig 12)**

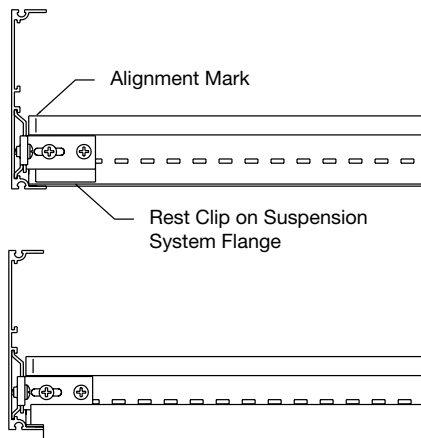

(Fig 12)

- b.2. Silhouette® XL®, Interlude® XL® HRC, and Sonata® (systems with a 5/16" shoulder height), Tegular panels on Prelude® or Suprafine® with the panel face resting on the trim flange, use AXTBC with tab cut off. **(Fig 13)**

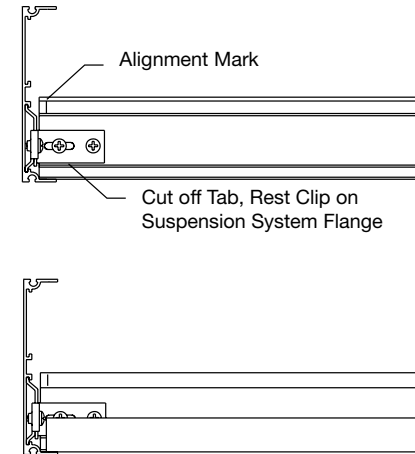

(Fig 13)

- b.3. MetalWorks™ Vector® (cut panels only) – use AXVTBC. **(Fig 14)**

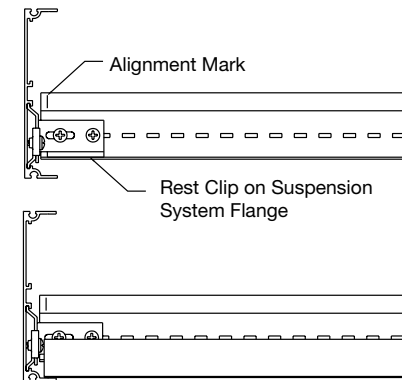

(Fig 14)

b.4. Ultima®, Optima®, and WoodWorks® Vector® and Optima® and Lyra® Concealed (cut panels only) – use AXVTBC with tab cut off (Fig 15).

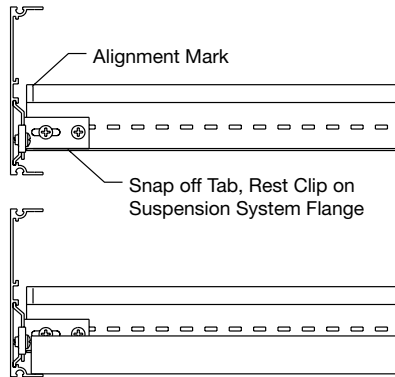

(Fig 15)

b.5. For products that require a grid offset from the Axiom flange that cannot be achieved with the AXTBC (0", 1/4") or the AXVTBC (3/8" or 1/2") – use the ATC (7239).

The ATC can be adjusted to install grid at 0" to 3-3/4" above the flange of the Axiom® at 1/8" increments (when tab is cut off). It is recommended that 6" Axiom® Classic or taller be used to enable the full range of adjustment. If 4" is used the adjustability is limited to 1-1/4" and the ATC is not compatible with 2" Axiom.

Examples of products which the ATC can be used to install Axiom Classic with are: MW Linear, MW Clip-On, MW Torsion Spring, MW Concealed, WW Linear, WW Grille and Altitudes®. (Fig 16)

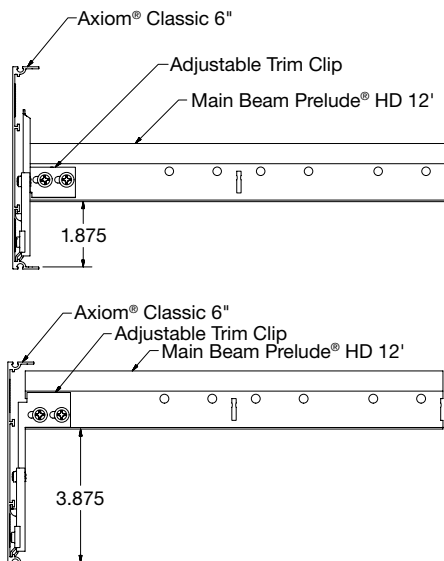

(Fig 16)

c. Attach the clips by aligning the end of the elongated hole with the reference mark on the suspension system and inserting a standard framing screw into the center of the slot.

5. Install the Axiom channel trim.

- a. Hang the sections of channel trim onto the suspension system by engaging the top ear of the connector clips under the boss of the channel trim. Slide the lower leg downward to engage the lower boss on the trim and secure by tightening the locking screw.
- b. Complete the installation of all channel trim sections. Install and secure the splice plates.
- c. Adjust the trim as necessary to properly align the completed installation. Insert a second framing screw through the round hole in each of the connector clips.

6. Add additional hanger wires as required.

- a. The manufacturer requires that Axiom systems and their supporting suspension systems be installed and supported in a manner that complies to all applicable codes and standards. Typically, this will require the use of #12 gauge galvanized, soft annealed steel wire or equivalent. Specification and approval of alternate materials should be by design professionals familiar with the project. Mechanics should exercise care in the application of hangers to minimize the visual impact on the finished installation. Wire wraps should be tight and neat, and where appropriate, the wires may be painted to blend into the background as much as possible.
- b. Main beams must be supported 4' O.C. or by calculation based on actual ceiling weight.
- c. Cross tees located on each side of a joint in the channel trim and then at 4' centers must be supported by wires located closer to the channel trim than their midpoint.
- d. Installations in areas requiring seismic restraint may require wires attached to each suspension system member within 8" of the cut end. This practice is highly recommended for all installations. Lateral force bracing shall be consistent with locally approved standards, or as detailed in the specifications.
- e. Axiom® Classic 10", 12", 14", and 16" profiles must be supported directly from the structure using two AX2HGC clips per section of trim and are included.

7. Install ceiling panels, tile, or drywall.

- Cut and install tiles or panels using standard procedures for the specified products.
- Treat exposed cut edges of ceiling panels as detailed in the project specifications.
- For drywall applications, attach 5/8" gypsum panels to the suspension system per the manufacturer's recommendations.

NOTE: The drywall bottom trim is designed to accommodate the full thickness of standard 5/8" drywall only. Lay out the position of the drywall panels to prevent tapered edges from falling at the location of the Axiom trim. Trim edges by applying the Axiom drywall bottom trim, screwed through the face of the gypsum panel and into the supporting suspension system members. Finish and paint using standard materials and techniques.

3.9 Brace 10", 12", 14", and 16" Channel Trims

The 10", 12", 14", and 16" high profiles require diagonal bracing to keep the face of the trim vertical. The spacing of this bracing will be dependent on the layout of the Axiom trim. Straight sections should be braced every 4'. Radius sections will require less bracing as the radius becomes smaller.

Fabricate the braces from the T-Bar suspension system and attach to the trim as shown below. (Fig 17)

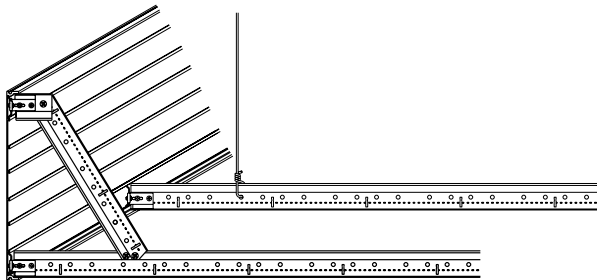

(Fig 17)

3.10 Direct Applied Applications

Direct applied applications of Axiom® are those in which the Axiom perimeter trim components are attached by screwing directly to a drywall or acoustical ceiling suspension system. The following section details the procedures to be followed for this type of installation.

Typical procedure

1. Lay out the pattern on the face of the supporting system.

- Drywall surfaces should be taped and sanded before application of the Axiom components.
- Trace the pattern onto the drywall. Note that when radius sections are shown on the shop drawings, the dimension is always measured from the face of the Axiom channel.
- Lay acoustical panels or pieces of drywall into exposed suspension systems to provide enough surface area to accurately trace the pattern.

2. Attach the channel trim sections to the structure.

- Insert appropriate length screws through the top flange of the channel trim sections and into the supporting members.
- Install splice plates and, where required, hanging clips as the work progresses.
- Adjust the location of channel trim sections as required.

3. Cut and install the specified suspension system to complete the installation.

- Prepare the T-Bar connector clips as described in Section 3.3. for suspended applications.
- Install T-Bar connector clips in the Axiom channels.
- Cut and install suspension system members and attach to T-Bar connector clips using standard framing screws.

4. Complete the installation of ceiling panels or drywall as described in Step 7 of Section 3.8. for suspended applications.

4. Final Detailing

4.1 Check and adjust the alignment of Axiom components and ceiling panels.

4.2 Clean exposed surfaces as required. Painted Axiom components may be wiped down with a mild household cleaner to remove fingerprints, oil, etc.

4.3 Touch up painted components as required. All painted custom Axiom shipments include a container of paint to be used for this purpose. Drywall systems are supplied with a conversion coating factory applied. After assembly, taping, and finishing, the Axiom components and drywall are field-painted according to specification.

MORE INFORMATION

For more information, or for an Armstrong Ceilings representative, call 1 877 276-7876.

For complete technical information, detail drawings, CAD design assistance, installation information, and many other technical services, call TechLine customer support at 1 877 276-7876 or FAX 1 800 572-TECH.

All trademarks used herein are the property of AWI Licensing LLC and/or its affiliates.

© 2023 AWI Licensing Company Printed in the United States of America

BPLA-295048-823

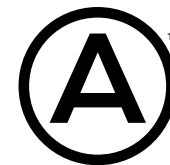

Armstrong[®]
World Industries