

CAD/Revit® drawings at:
armstrongceilings.com/cadrevit



▲ WoodWorks® Tegular panels with W2 perforation in Natural Variations™ Maple with Suprafine® XL® 9/16" exposed tee suspension system

armstrongceilings.com/capabilities
 See more photos at:
armstrongceilings.com/photogallery

Now get Total Acoustics® performance with WoodWorks® Tegular perforated panels – excellent noise reduction and sound blocking in one system.

KEY SELECTION ATTRIBUTES

- Get total noise control and design flexibility with Total Acoustics® ceiling panels: NRC + CAC = Total Acoustics
- Create upturns for continuous visuals and clouds with WoodWorks trim
- new** • CleanAssure™ family of products – includes disinfectable panels, suspension systems, and trim
- Coordinating WoodWorks walls available
- new** • Select products included in the FAST134 program – ready to ship in 4 weeks or less
- 18" x 18" Tegular infill panels now available for Metaphors® Coffers; for details, visit armstrongceilings.com/metaphors
- Shorter lead times and lower cost than custom millwork
- USDA Biobased Content: 100%

VENEERS Due to printing limitations, shade may vary from actual product.

Natural Variations™
 (Real Wood Veneers)



Constants™
 (Real Wood Veneers)

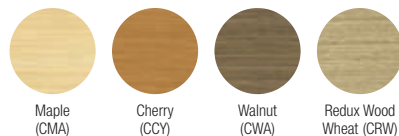

Bamboo*

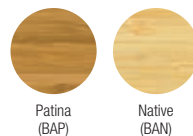

Custom Veneers and Finishes Available (extended lead times)

* Veneer is rapidly renewable. Bamboo is a grass that only requires 3-7 years for maturity and does not have to be replanted after each harvest.

PERFORATION OPTIONS (Actual 1:6 scale shown)

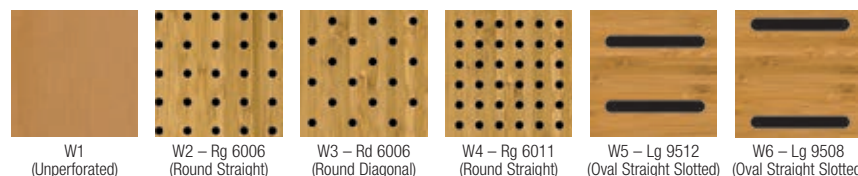

Custom Perforations Available

WOODWORKS®

Tegular

USDA
CERTIFIED
BIOBASED
PRODUCT
PRODUCT 100%



LEED® WELL | LBC
UP TO 63% RECYCLED CONTENT
energy management, construction waste mgmt, regional materials, design for flexibility, EPD, recyclable/extended producer resp., biobased materials, FSC® (for wood), recycled content, sourcing of raw materials, material ingredient reporting, low emitting materials, lighting quality, acoustics

Calculate sustainability with GreenGenie™
armstrongceilings.com/greengenie

VISUAL SELECTION

Edge Profile	Item No. ♦	Dimensions Nominal W x L x H (Inches) Custom Sizes Available	Perforations
WOODWORKS® Tegular 9/16" Square Tegular 	5404_____	24 x 24 x 3/4" □	W1, W2, W3, W4, W5, W6
FSC® certified WOODWORKS® Tegular 9/16" Square Tegular 	5406_____	24 x 24 x 3/4" □	W1, W2, W3, W4, W5, W6
	6484_____	12 x 48 x 3/4" ▬	W1, W2, W3, W4, W5, W6
	6485_____	12 x 72 x 3/4" ▬	W1, W2, W3, W4, W5, W6
	6486_____**	24 x 48 x 3/4" □	W1, W2, W3, W4, W5, W6
	6487_____**	24 x 72 x 3/4" ▬	W1, W2, W3, W4, W5, W6
TechZone® Panels	6510_____	24 x 42 x 3/4" □	W1, W2, W3, W4, W5, W6
	6511_____	30 x 30 x 3/4" □	W1, W2, W3, W4, W5, W6
	6512_____	27 x 30 x 3/4" □	W1, W2, W3, W4, W5, W6

FAST
4 WEEKS
or Less

FAST134 program items ready to ship from manufacturer in 4 weeks or less.
Up-to-date lead times and product options (sizes and colors) at armstrongceilings.com/fast134.

- ♦ When specifying or ordering, include the appropriate 2-digit perforation and 3-letter color suffixes. For veneers, sizes, and perforation patterns available as special order, call TechLine at 1 877 276-7876.
- ** 24" x 48" and 24" x 72" Tegular panels are available standard with fleece attached. Fleece on other panels must be specified.

NOTE: Items 6485 and 6487 (12" x 72" and 24" x 72" series) include suspension system stabilizer hooks. Items 6510, 6511, and 6512 are available in limited standard finishes and perforation options.

PERFORMANCE

Fire Rating	CleanAssure™ Disinfectable Panels			
	Fog	Spray	Wipe	
Class A	•	•	•	
Class A	•	•	•	
Class A	•	•	•	
Class A	•	•	•	
Class A	•	•	•	
Class A	•	•	•	
Class A	•	•	•	
Class A	•	•	•	
Class A	•	•	•	

ACOUSTICAL INFORMATION

Performance determined by perforation size. Dots represent high level of performance.

Perforation	Infill Panel Item No.	NRC	CAC	Total Acoustics ¹
W1 Unperforated		N/A	38	-
W2 Round Straight	8200T10	0.40	28	-
	5479	0.40	28	-
	5823	0.40	28	-
	1713BL	0.65	42	GOOD
	2820BK	0.70	37	BETTER
W3 Round Diagonal	8200T10	0.40	28	-
	5479	0.40	28	-
	5823	0.40	28	-
	1713BL	0.65	42	GOOD
	2820BK	0.70	37	BETTER
W4 Round Straight	8200T10	0.40	28	-
	5479	0.40	28	-
	5823	0.40	28	-
	1713BL	0.70	42	BETTER
	2820BK	0.70	37	BETTER
W5 Oval Straight Slotted	8200T10	0.40	28	-
	5479	0.40	28	-
	5823	0.40	28	-
	1713BL	0.70	42	BETTER
	2820BK	0.80	37	BEST
W6 Oval Straight Slotted	8200T10	0.40	28	-
	5479	0.40	28	-
	5823	0.40	28	-
	1713BL	0.65	42	GOOD
	2820BK	0.70	37	BETTER

¹ Total Acoustics® ceiling panels have an ideal combination of sound absorption and sound blocking in one product.

- GOOD (NRC 0.60-0.65; CAC 35+)
- BETTER (NRC 0.70-0.75; CAC 35+)
- BEST (NRC 0.80+; CAC 35+)



WOODWORKS®

Tegular

WOODWORKS® TRIM INSTALLATION

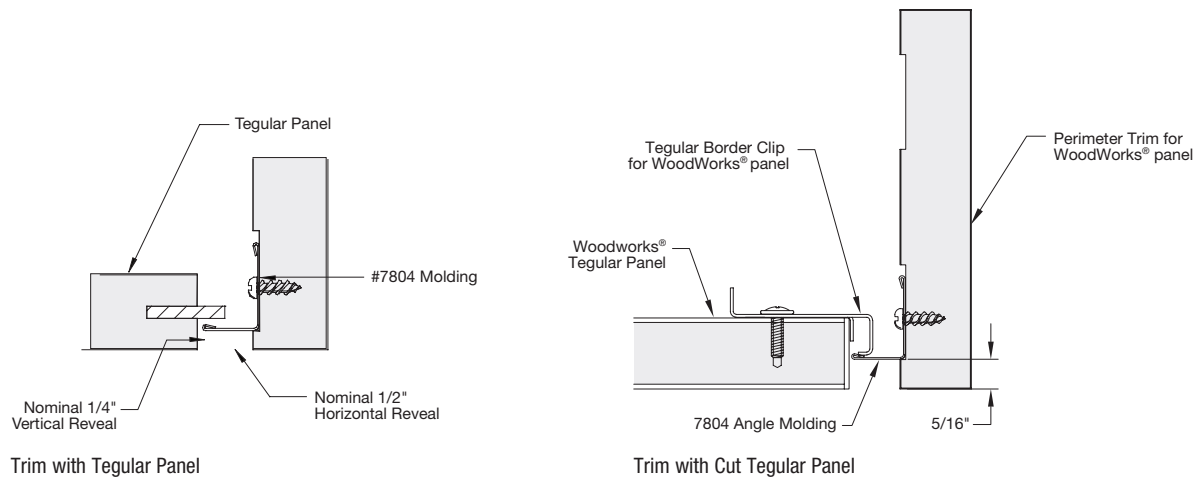

INSTALLATION OF TRIM (ALUMINUM SUBSTRATE) FOR WOODWORKS® PANELS

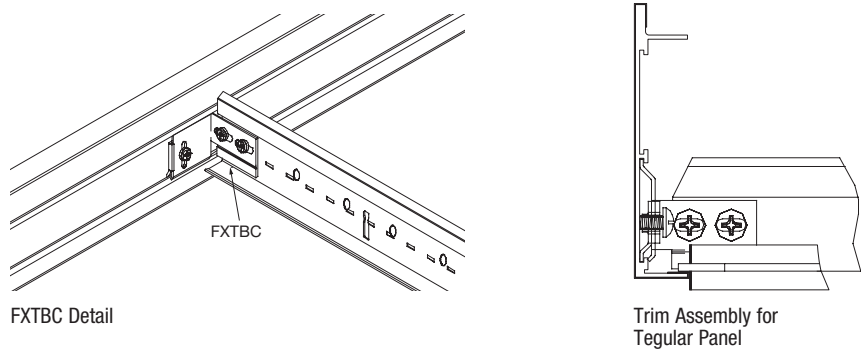

TOTAL ACOUSTICS® PANEL INSTALLATION



WoodWorks® Tegular ceiling panel with Calla® 2820 acoustic infill panel – Total Acoustics® ceiling system

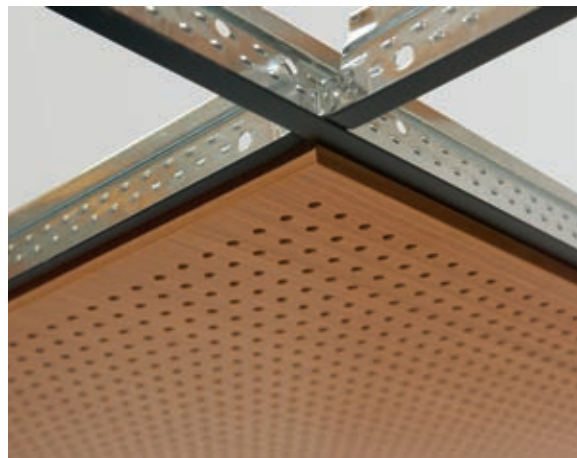

WoodWorks® Tegular ceiling panel with acoustical panel installed – Total Acoustics® ceiling system



WOODWORKS® – Standard

WOODWORKS®

Tegular

ACCESSORIES

Item No. ♦	Description	Dimensions (Inches) Nominal W x L x H	Color	Pcs/ Crtn
5415W1_ _ _	4" trim for WoodWorks® panels (with FSC® certified wood substrate)	4 x 96 x 3/4"	armstrongceilings.com/ wwaccessories	6
5419W1_ _ _	6" trim for WoodWorks® panels (with FSC® certified wood substrate)	6 x 96 x 3/4"	armstrongceilings.com/ wwaccessories	4
5659W1_ _ _	4" trim for WoodWorks® panels (with aluminum substrate)	4" x 120"	armstrongceilings.com/ wwaccessories	6
5660W1_ _ _	6" trim for WoodWorks® panels (with aluminum substrate)	6" x 120"	armstrongceilings.com/ wwaccessories	6
7804BL	Angle Molding (recommended with wood trims)	7/8 x 144 x 9/16"	Black	2
FXTBC	T-Bar Connector Clip	N/A	N/A	10
FXVTBC	T-Bar Connector Clip for Vector® panels	N/A	N/A	10
FXSPLICE	Splice Plate with Setscrews	N/A	N/A	10
FX4SPLICE	Splice Plate with Setscrews	N/A	N/A	10
6408_ _ _	3/4" Edge Banding	3/4" x 300"	armstrongceilings.com/ wwaccessories	N/A
7891	12-Gauge Hanger Wire	144" Length	N/A	N/A
92715A620	Self-tapping Screws	#2 x 3/4" Length	Black	25
1713BL	Fine Fissured™ Lay-in Panel	24 x 24 x 3/4"	Tech Black	14
2820BK	Calla® Lay-in Panel	24 x 24 x 1"	Black	10
5479	BioAcoustic™ Infill Panel	24 x 24 x 5/8"	Beige Matte	12
5823	BioAcoustic Infill Panel	24 x 24 x 5/8"	Black Matte	12
8200T10	Fiberglass Infill Panel	24 x 24 x 1"	Black Gloss	12
6091	Safety Cable	N/A	N/A	50
5870	WoodWorks® Touch-up (1 marker and 1 fill stick)	N/A	N/A	1

♦ When specifying or ordering, include the color suffix that coordinates with your WoodWorks ceiling: (e.g., 5415W1 N M P)



WoodWorks® Vector® with 4" WoodWorks Trim (wood substrate) in Bamboo Patina



Axiom® Trim also available in multiple colors and profile sizes. For details, visit armstrongceilings.com/axiom

SUSPENSION SYSTEMS (Heavy-duty)

9/16"
Tegular



Silhouette® HD



Suprafine® HD



Interlude® XL® HRC HD

Suprafine® suspension system is available in many standard colors. All other suspension systems are available in standard White only. Other colors available as special order.

PHYSICAL DATA

Material

Fire-retardant particle board with face-cut veneers; FSC® certified fire-retardant particle board with face-cut veneers (RA-COC-003601). For more information about FSC® certified fire-retardant products, or to view our FSC® certification letter, visit armstrongceilings.com/woodworksfsfc

Surface Finish

Clear or tinted semi-gloss coating

Fire Performance

Class A: ASTM E84 surface burning characteristics. Flame Spread Index 25 or less. Smoke Developed Index 50 or less.

CAN/ULC S102 surface. Flame Spread Rating 25 or less. Smoke Developed Classification 50 or less.

Acoustical Performance

CAC testing conducted using Silhouette® suspension system.

ASTM E1264 Classification

ASTM E1264 Type XX - Fire Class A

Primary (Embodied) Energy

See all LCA information on our EPDs.

Application Considerations

Variation among panels may occur due to the natural characteristics of the wood and grain.

It is very important that WoodWorks® panels are climatized prior to installation. Relative humidity between 25% and 55%, and temperatures between 50°F and 86°F, must be maintained throughout the life of the product.

Design Considerations

Different panels should not be installed together. Perforated border on 24" x 72" panels are different than other panel sizes.

Specification Consideration

Attention: For FSC® certified wood products to maintain their CoC certification, products must be sold to a CoC-certified distributor or directly to the installing contractor. Failure to do so breaks the CoC.

Installation Consideration for Tegular Panels

Due to panel weight, 24" x 48" and 24" x 72" panels require that the suspension system be attached to the back with safety cables attached. 12" x 72" and 24" x 72" panels require the use of suspension system stabilizer clips (which are included in the cartons).

Seismic Restraint

WoodWorks Tegular solid wood panels have been engineered, tested, and approved for application in all seismic areas when installed per Armstrong Ceilings installation instructions.

Cleaning and Disinfecting

Cleaning and CDC approved disinfecting options available on armstrongceilings.com/cleaning

FAST134 Program Considerations

Size of Job Matters: Big jobs, over 2500 SF or 50 pieces for shapes/vertical elements will have longer lead times.

Location Matters: Transit time not included. We are ready to ship in 1 week on FAST1 items. However, transit to the states west of Wyoming may add time.

Distributor Truck Schedule Matters: We rely on distribution to help move products around the country. When speed matters, work with your local distributor to ensure FAST134 service.

Stock vs Made-to-Order Matters: FAST3 & FAST4 items are made-to-order and will ship direct to distributor. FAST1 (stocked items) will go through distribution and depend on distributor truck schedules.

Warranty

Details at armstrongceilings.com/warranty

Weight; Square Feet
Panels – 2.75 lbs/SF