



TECHNICAL GUIDE



**A FRAMEALL™
DRYWALL GRID
SOLUTION**

CORRIDOR FRAMING SYSTEM
SHORTSPAN®



Armstrong®
World Industries

SIMPLE & FAST

FASTER. EASIER. BETTER.

ShortSpan® Corridor Framing System, a member of the FrameAll Drywall Grid Family of Solutions, is the fastest way to frame drywall ceilings up to 14' wide, while also eliminating hanger wires/drops for spans up to 8'-6".

The ShortSpan system is designed and manufactured to meet or exceed ASTM standards and code requirements. This engineered corridor system helps installers get on and off the job faster, easier, and better.

ShortSpan framing is an effective and productive solution for use in corridors, small rooms, closets, restrooms and more.



CODE COMPLIANCE YOU CAN TRUST

- | | |
|---|---|
| Meets: | · Department of State Architect – DSA PA105 |
| · ASTM C645 | · City of LA – RR 25348 |
| · ASTM C840 | · Consult local codes for specific requirements |
| · ASTM C754 | |
| · ICC Evaluation Report Number ESR-1289 | |

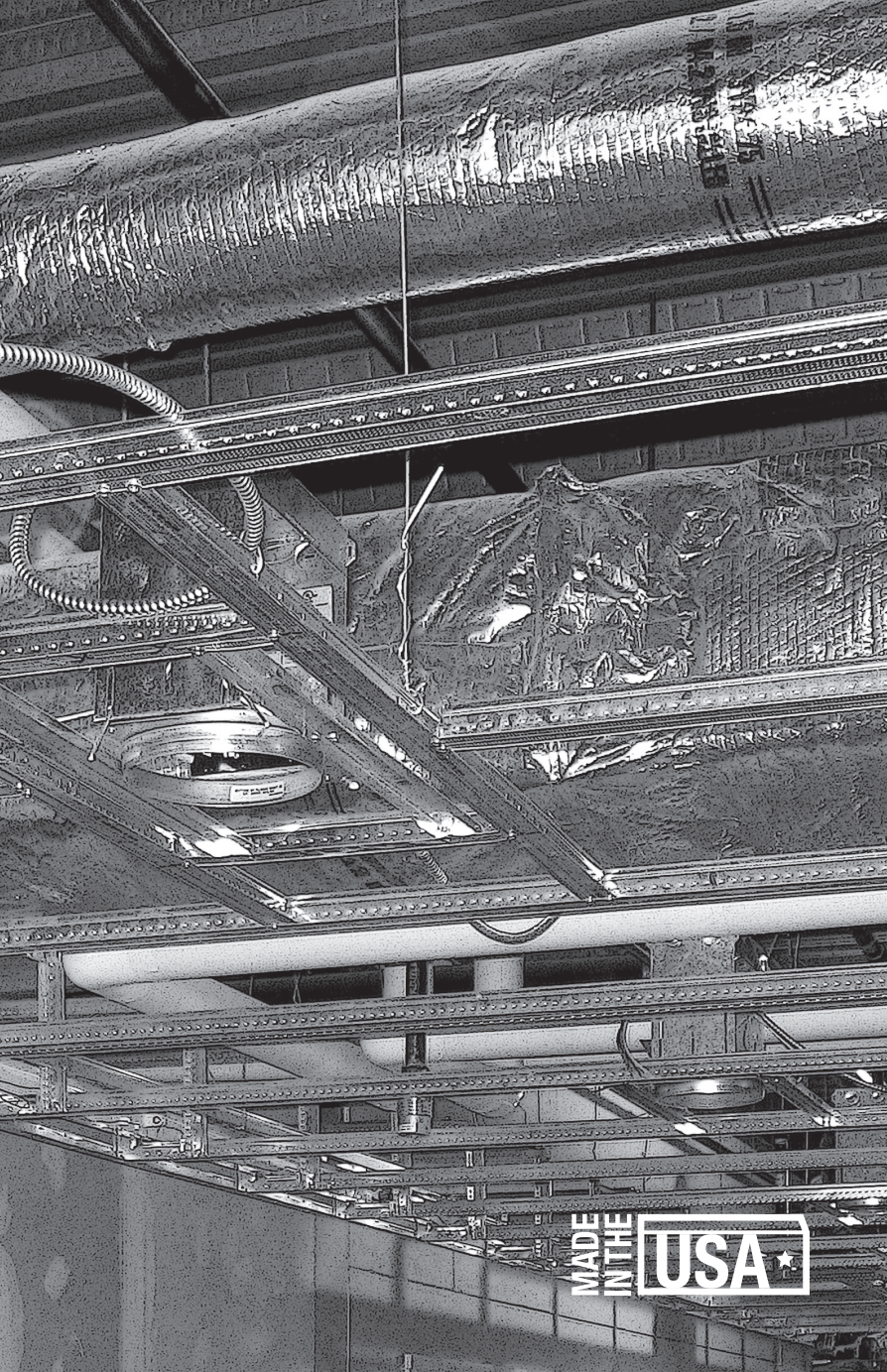

TABLE OF CONTENTS

- 2-3 Code Compliance & Performance
- 4 Components & Moldings
- 5 ShortSpan® Framing System – Interior Drywall Ceilings
- 6 ShortSpan® Corridor System
- 7 Locking Angle Molding / Installation Notes
- 8 ShortSpan® StongBack™ Support
- 9 Knurled Angle Molding
- 10 Fire Rated ShortSpan®
- 11 Locking Pocket Mains
- 12 Load and Vertical Supports
- 12-13 Integrated Solutions

ShortSpan Framing System



PERFORMANCE

- PeakForm profile, eliminates hanger wires at span of 7' 6" @ 24" O.C. at 8' 6" @ 16" O.C.
- ScrewStop™ reverse hem prevents screw spin off
- Select items available in High Recycled Content (HRC): 61% Total Recycled Content, 53% Post Consumer Content, 8% Pre-Consumer Content
- Non-HRC items have 30% recycled content
- Components meet broad range of UL® design assemblies (ShortSpan® Tee, LAM, SB12)
- G40, 0.018" metal thickness meets ASTM C645
- G90 hot-dipped galvanized coating available for interior high-moisture area
- Rotary stitching on double web adds strength and stability
- Deep knurled surface for easy screw insertion

COMPONENTS & MOLDINGS

SHORTSPAN® ITEM DETAILS

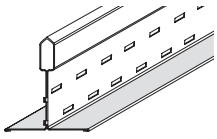
ShortSpan® Item Data

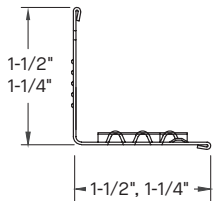
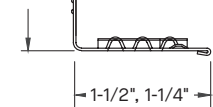
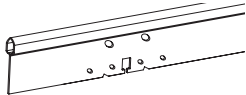
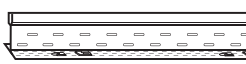
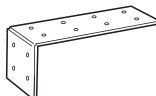
Item Number	Length/Item Description	Face Dimension	Profile Height	Simple Span Uniform Load at L/240 (LBS/LF)	Fire Resistive	
S7708P S7708PHRC S7708PG90	8' ShortSpan® Cross Tee	1-1/2"	1-13/16"	All items		
S7710P S7710PHRC S7710PG90	10' ShortSpan Cross Tee	1-1/2"	1-13/16"	5 ft. Span – 14.18		
S7712P S7712PHRC S7712PG90	12' ShortSpan Cross Tee	1-1/2"	1-13/16"	6 ft. Span – 10.49		
S7714P S7714PHRC S7714G90	14' ShortSpan Cross Tee	1-1/2"	1-13/16"	8 ft. Span – 4.43		
SLP7704 SLP7705 SLP7706	47-13/16" 59-13/16" 71-13/16" ShortSpan Low Profile		7/8" 7/8" 7/8"	-		
LAM12 LAM12G90 LAM12HRC	12' Locking Angle Molding (Locking tabs 8" O.C.) 0.018" Metal Thickness	1-1/4" x 1-1/4"	-	-		
LAM151220E	12' Locking Angle Molding (Locking tabs 8" O.C.) 0.028" Metal Thickness	1-1/2" x 1-1/2"	-	-		
SB12P	12' StrongBack™ Support (knockouts 8" O.C.) 0.018" Metal Thickness	-	2"	-		
QSLPM12	12' QuikStix™ Locking Pocket Main (Locking tabs 8" O.C.) 0.018" Metal Thickness	1-1/2"	1-1/2"	Vertical Supports @ 4' O.C. - 21.64 Vertical Supports @ 3' O.C. - 40.60	-	
QSUTC	QuikStix Upright Clip (Pre-drilled screw holes)	1-3/4" wide	1-1/2" x 4-1/2"	-	-	

NOTE: All components are available with G90 hot-dipped galvanized coating. Just add G90 suffix to end of Item #, Ex: LAM12G90. "P" at the end of Item numbers means PeakForm bulb

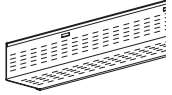
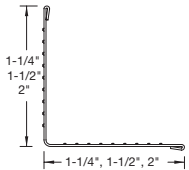
Perspective	Item No.	Length	Height	Metal Thickness	Pcs/Ctn	LF/Ctn	Profile
	KAM10	120"	1-1/4"	0.018"	10	100	
	KAM12	144"	1-1/4"	0.018"	10	120	
	KAM12G90	144"	1-1/4"	0.018"	10	120	
	KAM1510	120"	1-1/2"	0.018"	10	100	
	KAM1512	144"	1-1/2"	0.018"	10	120	
	KAM151020E	120"	1-1/2"	0.028"	10	100	
	KAM151220E	144"	1-1/2"	0.028"	10	120	
	KAM151020	120"	1-1/2"	0.033"	10	100	
	KAM1525G90	120"	1-1/2"	0.018"	10	100	
	KAM1520G90	120"	1-1/2"	0.018"	10	100	
	KAM21025	144"	2"	0.018"	10	100	
	KAM21020EQ	120"	2"	0.028"	10	100	
	KAM21020	120"	2"	0.033"	10	100	

THE BEST CHOICE FOR FRAMING SHORT SPANS

Reduce Labor Cost:	Eliminates screws, cross tees and hanger wire (in most applications)
Reduce Material Cost:	Economical price point on components
Reduce Waste:	Standard and custom lengths – no cartons to throw away
Reduce Risk:	System was evaluated using full-scale seismic testing and may be an acceptable solution on your next project. Check with your local code official for approval prior to installations. For official test reports, please contact TechLine at 877 267-7876.
Fire Rated:	Up to 2-hour rating with one (1) layer of fire-rated gypsum board. (See pages 8 and 9 for drawing detail.) Resistive when used in applicable UL® fire resistive designs. Fire Guard™ components meet UL Design Listings D501, D502, G523, G524, G526, G527, G528, G529, G531, G553, J502, L502, L508, L513, L515, L525, L526, L529, L564, P501, P506, P507, P508, P509, P510, P513, P514.

SHORTSPAN FRAMING TEES ARE ENGINEERED FOR FASTER, EASIER INSTALLATION

- 1-1/2" wide face exceeds the minimum industry standard
- ScrewStop™ reverse hem prevents screw spin-off
- Balanced profile stays flat during installation
- Rotary stitching on double web adds strength and stability
- Deep knurled surface for easy screw insertion
- G40, .018" metal thickness meets ASTM C645
- Reduced cleanup and waste at jobsite
- Quick to open
- Cut to length with snips or saw



ShortSpan Framing and Locking Angle Molding make drywall framing faster and easier

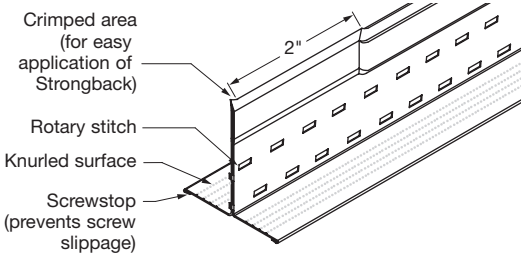

Corridor framing using traditional steel studs

Traditional Method to Frame Corridors

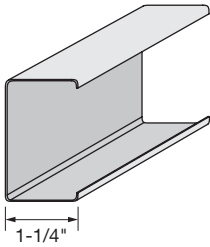

NO CARDBOARD CARTONS



TIME SAVING SOLUTION FOR CONGESTED PLENUM INSTALLATIONS

- Eliminates the need for hanger wire
- Reduced labor costs over conventional installation methods in congested plenum
- Alignment crimps at locking tabs for fast, easy alignment

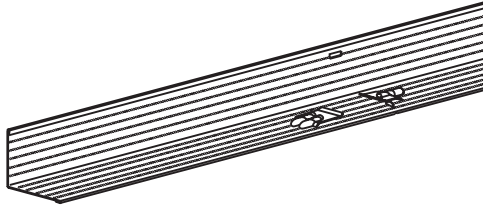

12' Locking Angle Molding (LAM12) – Wall angle molding fabricated from hot-dipped galvanized steel. The molding features locking details at 8" centers that lock and hold the ShortSpan® framing tees.

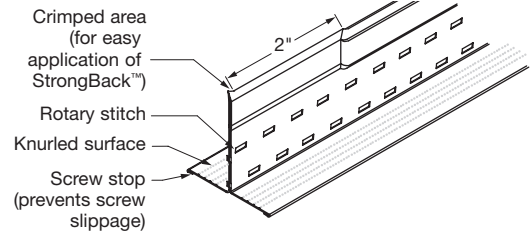

ShortSpan Tee (S7708P, S7710P, S7712P, S7714P) – ShortSpan eliminates cross tees, screws, and hanger wire. Rotary stitching on double web adds strength and stability. G40, .018" metal thickness meets ASTM C645.

LOAD TEST DATA

ShortSpan Cross Tees	Web Height	Hanger Spacing Uniform Load at L/240 (LBS/LF)							
		3'	4'	5'	6'	7'	7'-6"	8'	8'-6"
S77**P	1-13/16"	-	31.76	14.18	10.49	5.84	5.54	4.43	3.37
QuikStix™ Locking Pocket Main									
QSLPM12	1-1/2"	40.60	20.87	-	-	-	-	-	-
StrongBack™ Support Hanger									
SB12P	2"	27.53	17.76	-	-	-	-	-	-

MAXIMUM ALLOWABLE LOAD, LBS./SF @ L/240 DEFLECTION

(spans 8'-6" to 14', require StrongBack)

Item Number	O.C. Spacing	4' Span LBS/SF	5' Span LBS/SF	6' Span LBS/SF	7' Span LBS/SF	7'-6" Span LBS/SF	8' Span LBS/SF	8'-6" Span LBS/SF	9' Span LBS/SF	10' Span LBS/SF	12' Span LBS/SF	14' Span LBS/SF
S77**P	8"	-	21.27	15.74	8.76	8.31	6.65	5.06	4.46	21.27	15.74	8.76
S77**P	16"	23.82	10.64	7.87	4.38	4.16	3.32	2.53	2.23	10.64	7.87	4.38
S77**P	24"	15.88	7.09	5.25	2.92	2.77	2.22	1.69	-	7.09	5.25	2.92
SLP77**	16"	5.12	2.61	1.52	-	-	-	-	-	-	-	-
SLP77**	24"	3.41	1.74	-	-	-	-	-	-	-	-	-

Red numbers are Fire Guard items.

NOTE: 5/8" drywall weighs 2.4 lbs./SF (tees installed 8" or 16" or 24" O.C.)
1/2" drywall weighs 2.0 lbs./SF (tees installed 16" O.C., maximum)
KAM or LAM angle is required to achieve the listed loads above.

INTERSECTING CORRIDORS, SHORTSPAN, I-BEAM GIRDER

I-Beam Span (A)	Intersecting Corridor Span (B)					
	4'	5'	6'	7'	8'	8'-6"
6'	5.00+	5.00+	5.00+	5.00+	4.57	4.35
7'	5.00	4.29	3.75	3.33	3.00	2.86
7'-6"	4.33	3.71	3.25	2.89	2.60	2.48
8'	3.82	3.28	2.87	2.55	-	-
8'-6"	3.00	2.57	-	-	-	-

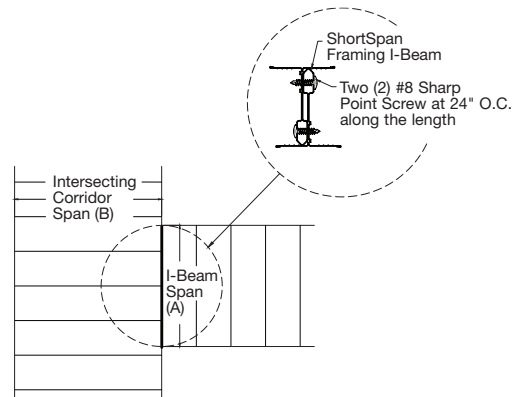

NOTE: Use this detail when a wire to structure is not feasible.

LOCKING ANGLE MOLDING: A FASTER, MORE ACCURATE SOLUTION

- Pre-engineered locking tabs punched 8" O.C.:
 - Eliminates measuring 16" or 24"
 - Locking tabs prevent lateral and upward movement
 - Eliminates screws, pop rivets, or crimpers needed to attach tees to molding
- Knurled surface on both flanges
- ScrewStop™ reverse hem prevents screw spin-off and provides safer handling
- Alignment crimp at locking tabs for fast, easy alignment
- Locking Angle Molding is designed to only work with Armstrong® ShortSpan® products



ShortSpan tee engaged in Locking Angle Molding

INSTALLATION NOTES

ShortSpan® Tees:

- 1 ShortSpan tees must be cut within 1/8" of the vertical leg of the Locking Angle Moldings (for non-rated installations only).
- 2 Must screw LAM to wall structure (#8 x 1-1/4" wafer head self drill sheet metal screws tested in 25- and 20- gauge steel studs).
 - Assembly tested to 200 lbs. for shear and screw pullout without failure (refer to Maximum Load chart on page 11)
- 3 Insert right hand flange of tee into pocket "A" first and allow left flange to clear pocket "B" and rest on angle molding. Slide tee to the left to engage in pocket "B" (audible click)

No Additional Requirements For Seismic Areas
There's no need to screw ShortSpan Tees to Locking Angle Molding in Seismic Design Categories A-F (unless required by local code).

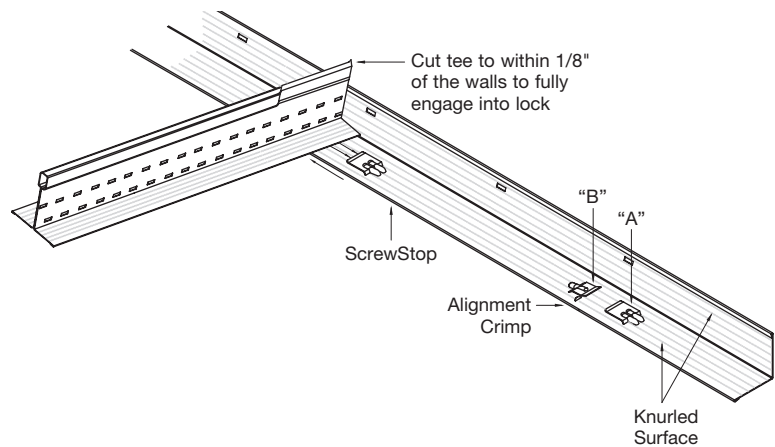

**SHORTSPAN®
STRONGBACK™ SUPPORT**

EASIER, PRE-ENGINEERED SOLUTION TO SUPPORT SPANS UP TO 8' - 6"

- Knockouts 8" O.C. eliminates measuring, screwing, and splicing
- Allows vertical supports at 4' O.C. instead of 24" or 16"
- Reduces lateral movement
- Resists upward movement if used with vertical tee post or stud
- Easier to level system compared to traditional framing

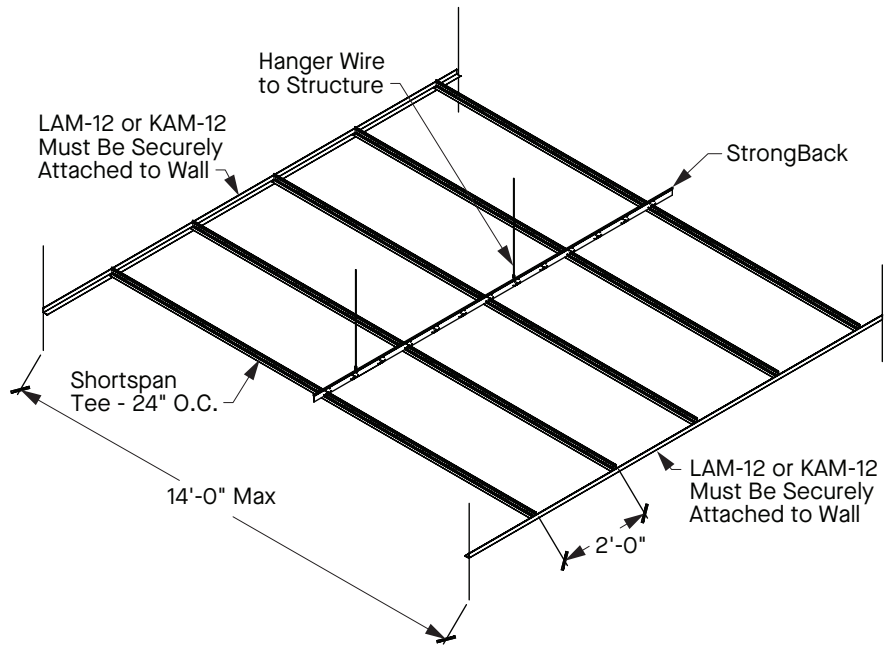

INSTALLATION RECOMMENDATIONS

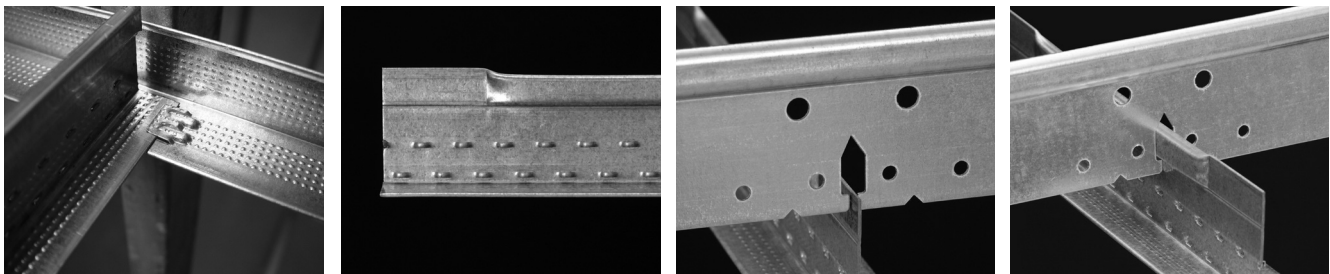

- 1 Install Locking Angle Molding (LAM) or KAM to wall and lock in ShortSpan tees (S77XXP) into LAM or KAM
- 2 Flattened bulb allows StrongBack to slide over bulb
- 3 Slide StrongBack into place – no bending of tab required

ALTERNATIVE METHOD TO INSTALL STRONGBACK™ SUPPORT HANGER

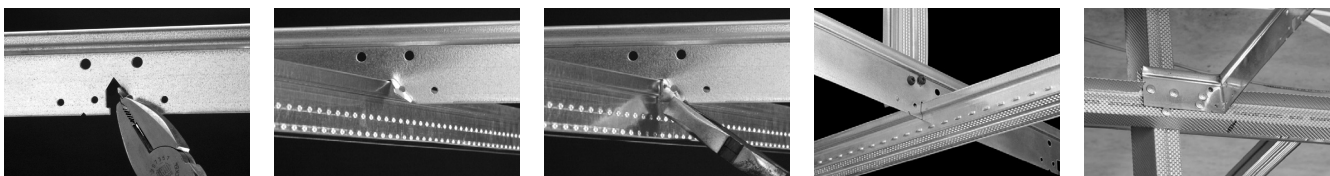

- 1 Open StrongBack (SB12P) lock tabs with pliers (easier if performed on floor)
- 2 Slide StrongBack over bulb of ShortSpan tee and engage by bending lock tabs back to original position
- 3 Support and level system to structure; attach vertical supports to StrongBack as required
- 4 To provide stability to StrongBack, it is recommended to bend first 4" to 90° and pin to wall

MORE INSTALLATION BENEFITS IN ENHANCED DRYWALL FRAMING SYSTEM WALL ANGLE

Knurled Angle Molding (KAM) for drywall framing has the time-saving advantages of knurling, ScrewStop™, pre-punched holes, and no cartons to throw away.

Knurling:	Helps the screws to grab quickly.
ScrewStop:	Reverse hem on the top and bottom flanges catches the screw, preventing it from slipping off the wall angle – no sharp edges on the top or bottom of the angle.
Pre-punched Holes:	Located every 4" on the top edge to allow for faster insertion of the screws.
No Carton Packaging:	Eliminate time needed to open and throw away cartons. Just cut the plastic strap and go.

- Meets ASTM C645 code and gauge specification
- Available in 10-piece bundles in 10' and 12'
- Straighter, Stronger, Safer runs
- Space your soffits framing 4' O.C. with no overlapping and no scrap
- Locking Angle Molding (LAM) product available
- SimpleCurve® Angle Molding product available for curved conditions

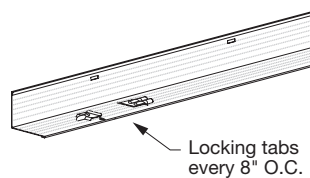
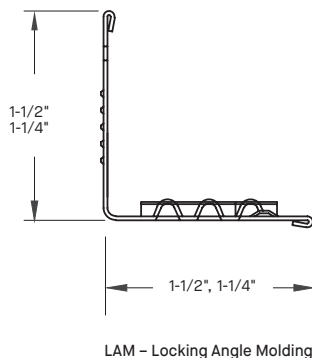
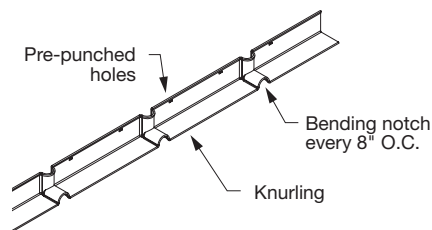
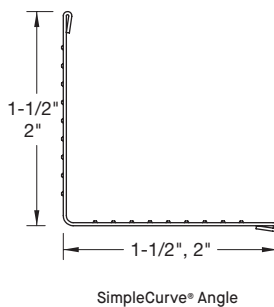
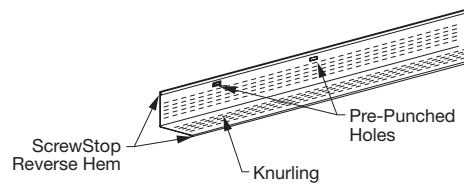
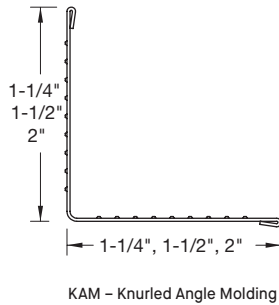

FIRE RATED SHORTSPAN

FIRE RATED

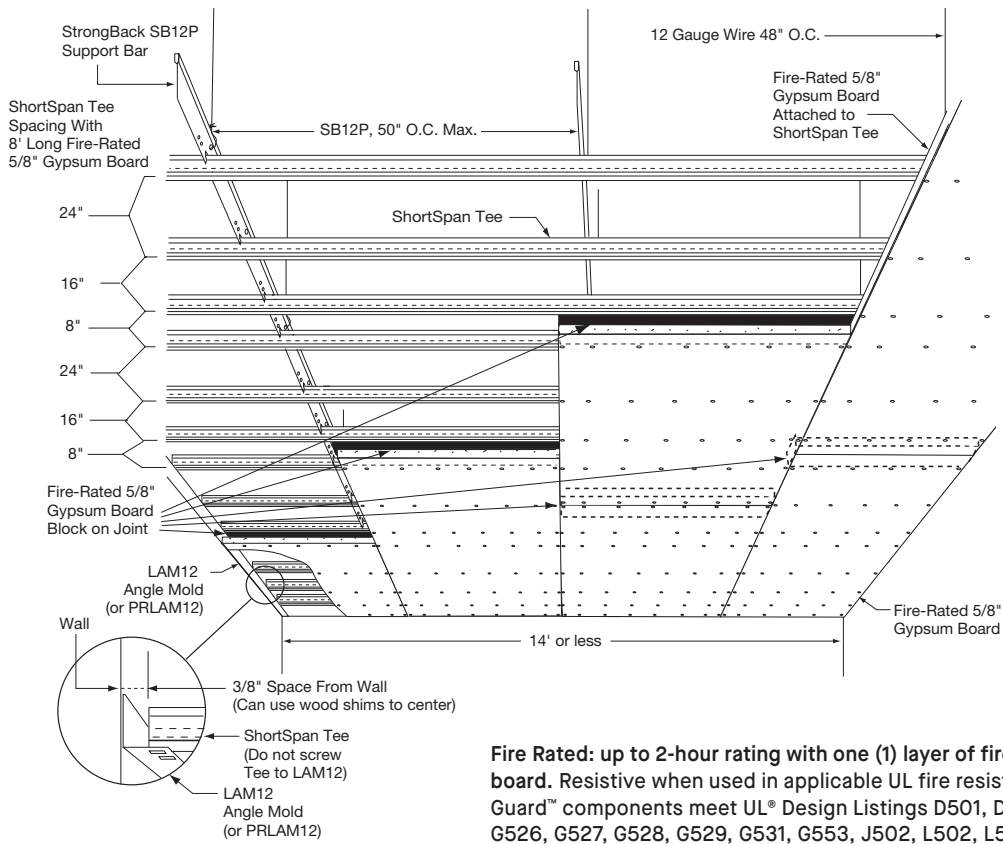

Fire Rated: up to 2-hour rating with one (1) layer of fire rated gypsum board. Resistive when used in applicable UL fire resistive designs. Fire Guard™ components meet UL® Design Listings D501, D502, G523, G524, G526, G527, G528, G529, G531, G553, J502, L502, L508, L513, L515, L525, L526, L529, L564, P501, P506, P507, P508, P509, P510, P513, P514.

NOTE:
For complete installation details
See specific UL designs.

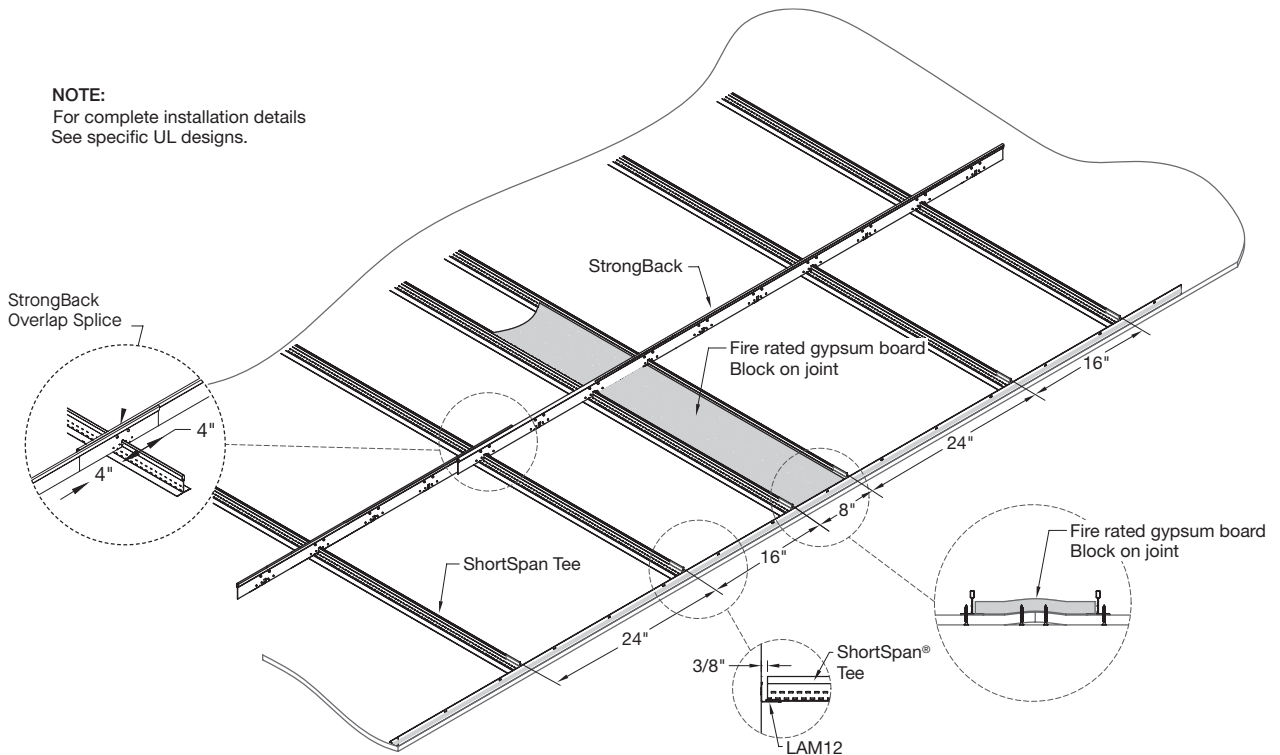

LOCKING POCKET MAINS

- Reduces time and labor installing drywall ceilings in tight plenum conditions
- Upright clip allows installation in 1-1/2" to 5-1/2" plenums
- Locking Pocket Main has the same characteristics as StrongBack™
- Locking Pocket Main allows upright installation since it is installed at the same level as the ShortSpan tees
- ShortSpan® Tees can span up to 8'-6" without vertical support (16" O.C.)
- Locking Angle Mold eliminates measuring, marking and screwing at perimeters

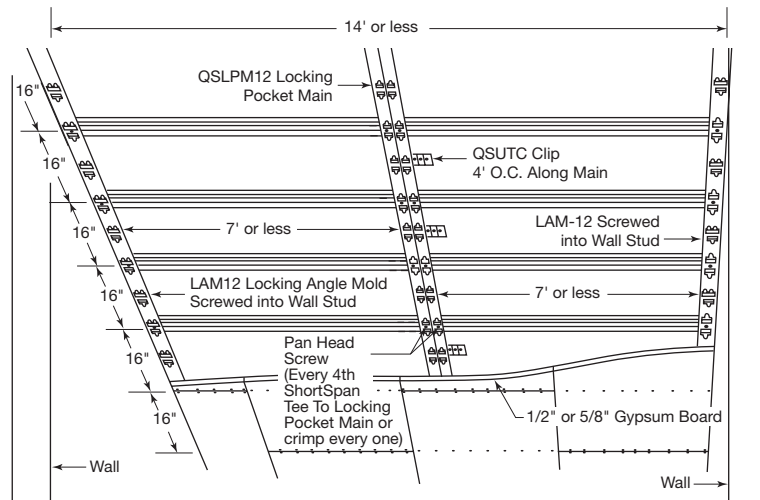

MAXIMUM LOAD IN LBS/SF (L/240 PER ASTM C645)

Main Beam O.C. Spacing	Vertical Support (Tee Post, Hanger Wire, or QSUIC) Spacing Along Main Beam	Max Load in LBS/SF
QLSPM12 – 4' O.C.	4'	5.22
QLSPM12 – 5' O.C.	4'	4.17
QLSPM12 – 6' O.C.	4'	3.48
QLSPM12 – 7' O.C.	4'	2.98
QLSPM12 – 7'6" O.C.	4'	2.78
QLSPM12 – 8' O.C.	4'	2.61
QLSPM12 – 8'6" O.C.	4'	2.46

Main Beam O.C. Spacing	Vertical Support (Tee Post, Hanger Wire, or QSUIC) Spacing Along Main Beam	Max Load in LBS/SF
QLSPM12 – 7' O.C.	3'	6.60
QLSPM12 – 7'6" O.C.	3'	6.16
QLSPM12 – 8' O.C.	3'	5.77
QLSPM12 – 8'6" O.C.	3'	5.43
QLSPM12 – 8'6" O.C.	3'	-

NOTE: 5/8" drywall weighs 2.4 LBS/SF or less
 1/2" drywall weighs 2.0 LBS/SF or less
 Fixtures should be independently supported
 *For other combinations; consult TechLine at 877 276-7876

INSTALLATION RECOMMENDATIONS

- 1 Vertical supports to structure should be either QuikStix™ Upright Clips or stiff legs using scrap metal. Wire is NOT recommended for hanging this system.
- 2 ShortSpan tees must be cut within 1/8" of vertical leg of the Locking Angle Moldings and Locking Pocket Mains.
- 3 To engage ShortSpan tees into Locking Pockets: insert right hand flange of tee into long pocket first and allow left flange to clear short pocket; rest flat. Slide tee to the left to engage in short pocket (audible click).

Upright Clip (QSUIC): Saves time in tight plenum areas and is adjustable to uneven surfaces

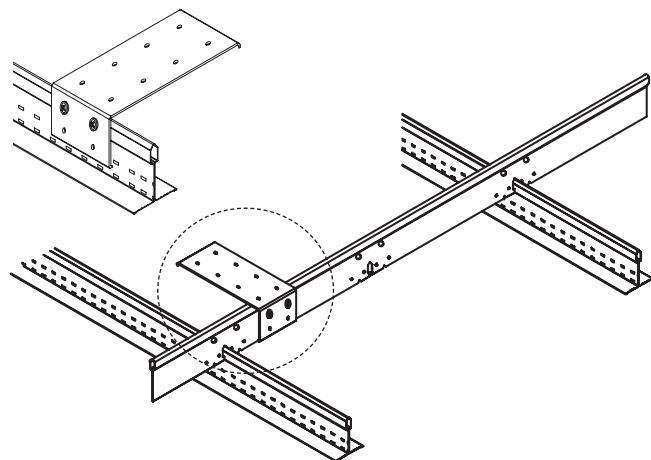

LOAD AND VERTICAL SUPPORTS

LOAD AND VERTICAL SUPPORTS

SHORTSPAN® VERTICAL SUPPORT REQUIREMENTS

Tees installed 16" O.C. with 5/8" or 1/2" drywall (Seismic Design Categories A, B, C, D, E, F)

Up to 8'-6" span	No vertical support required
8'-6" to 14' 0" span	Mid-span vertical support required

Tees installed 24" O.C. with 5/8" drywall (Seismic Design Categories A, B, C, D, E, F)

Up to 7'-6" span	No vertical support required
7'-6" to 14' 0" span	Mid-span vertical support required

SECTION PROPERTIES - ASTM C754 TABLE 3

Section	Min. Base Metal Thickness (in)	Design Thickness (in)	Gross Area (in ²)	Effective Properties	
				I _{xx} 2 (in ⁴)	Ma (ft-lb)
ShortSpan®	0.0179	0.018	0.099	0.03633	52.33
StrongBack™	0.0335	0.034	0.092	0.033	45.6

VERTICAL SUPPORT OPTIONS



Hanger Wire

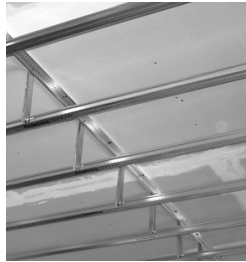

Scrap Tee Post

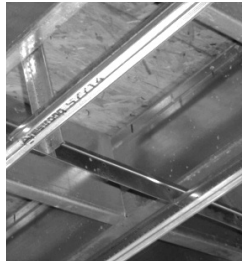

Manufactured StrongBack



Field Assembled Support



QuikStix™ Uptight Clip

SPANS & SUPPORT OPTIONS

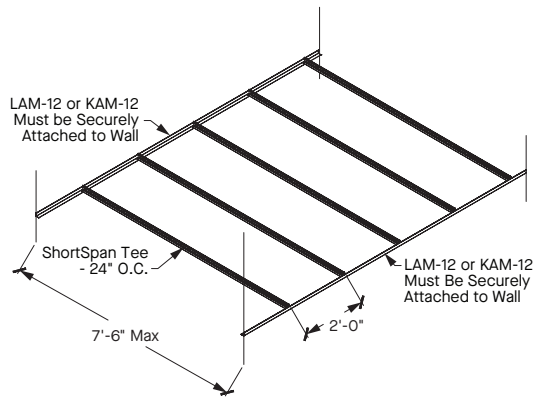

24" O.C. spacing of ShortSpan at max span of 7'-6"

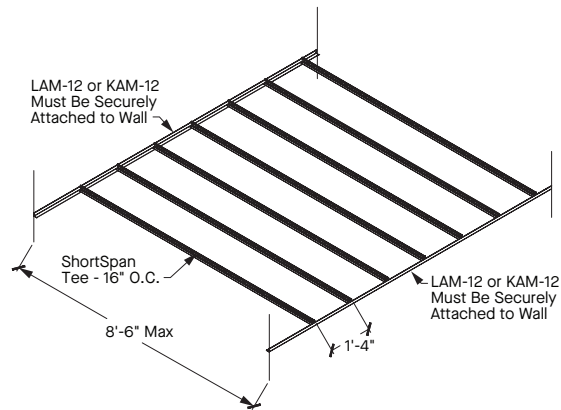

16" O.C. StrongBack at max span of 8'-6"

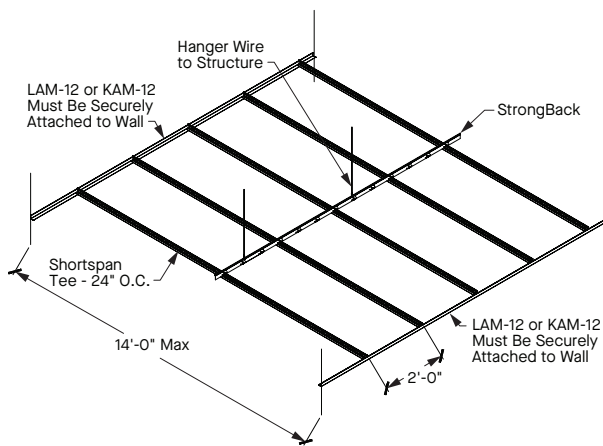

24" O.C. spacing of ShortSpan® showing StrongBack™

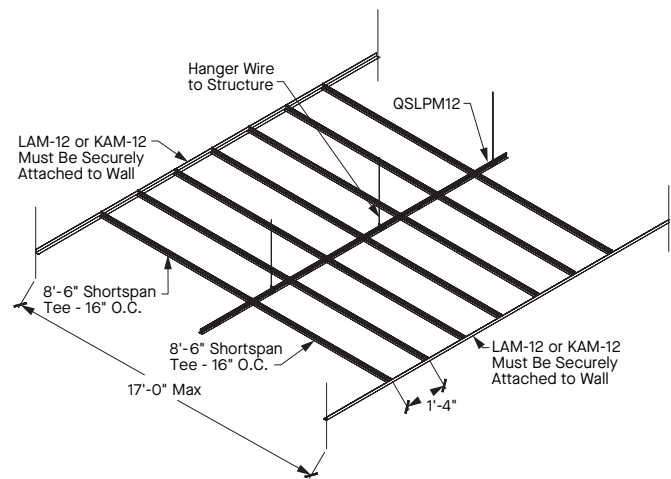

16" O.C. spacing of ShortSpan showing Locking Pocket Mains

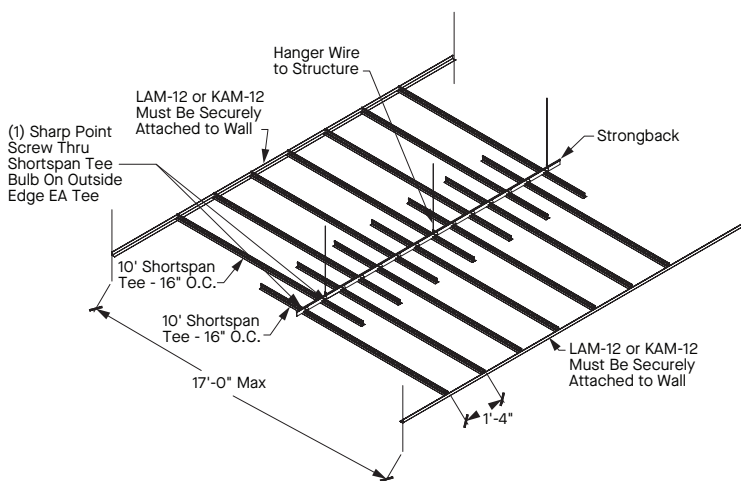

16" O.C. staggered, cantilever layout for 17' max span

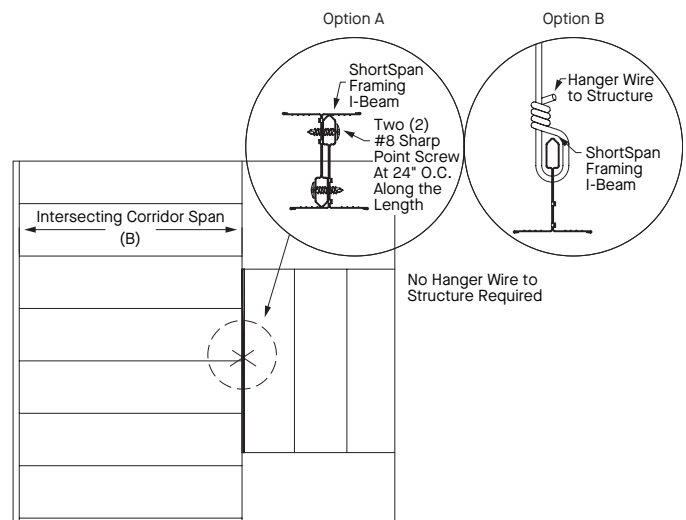

ShortSpan Intersection Corridors with I-Beam Girder

INTEGRATED SOLUTIONS

TRANSITIONS

ShortSpan at Perimeter Wall

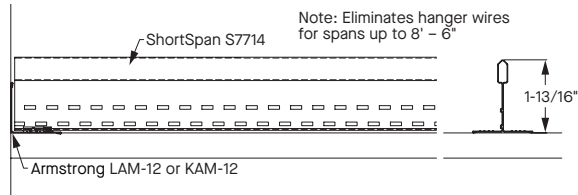

ShortSpan Low Profile at Perimeter Wall

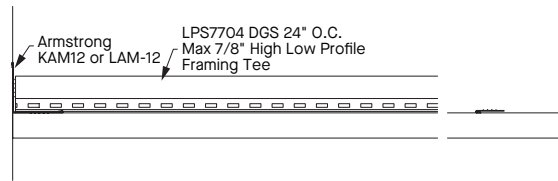

ShortSpan with StrongBack Splice Application

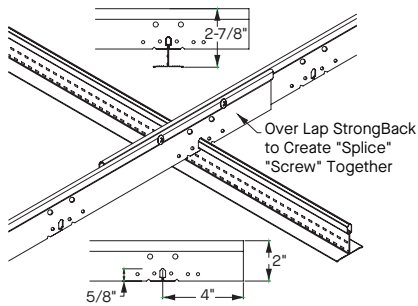

ShortSpan at Wall

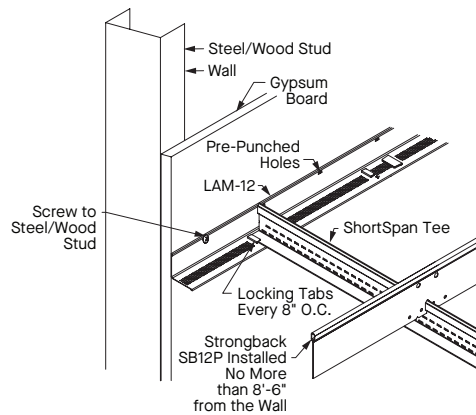

Fixture Installation

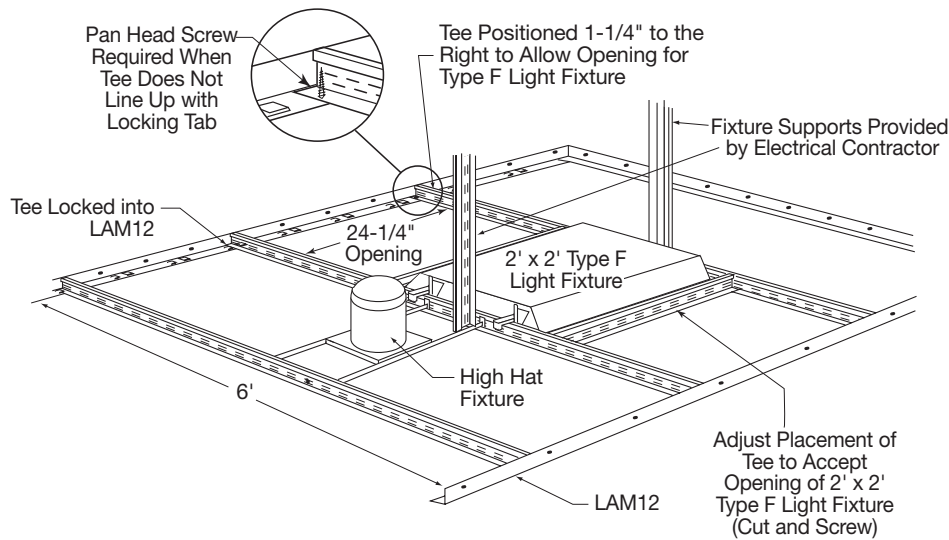

NEXT STEPS

877 276-7876

Customer Service Representatives
7:45 a.m. to 5:00 p.m. EST
Monday through Friday

TechLine – Technical information, detail drawings, CAD design assistance, installation information, other technical services – 8:00 a.m. to 5:30 p.m. EST, Monday through Friday. FAX 800 572 8324 or email: techline@armstrongceilings.com

armstrongceilings.com/commercial

Latest product news

Standard and custom product information

Online catalog

CAD, Revit®, SketchUp® files

A Ceiling for Every Space® Visual Selection Tool

Product literature and samples – express service or regular delivery

Contacts – reps, where to buy, who will install



armstrongceilings.com/savingscalc

The Armstrong Time, Material & Labor Savings Calculators are here to help you save vs. traditional construction methods.

Just plug in your job specific details and receive a complete dashboard with side-by-side comparisons, solution benefits, details, and photos that can be used on your next project or shared with a project resource.

Visit the link above to start saving time and money today!

