

# METALWORKS™ Blades – Classics

Linear Panels with Acoustical Options  
smooth texture



**SUSTAIN™**  
High Performance  
Sustainable  
Ceiling Systems



**FAST134**  
Select Items Ship Fast  
[armstrongceilings.com/fast134](http://armstrongceilings.com/fast134)



CAD/Revit® drawings at:  
[armstrongceilings.com/cadrevit](http://armstrongceilings.com/cadrevit)

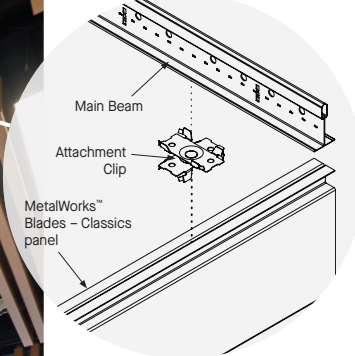

plus capabilities  
to do more



MetalWorks Blades – Classics 2" x 6" panels in Effects Cherry

[armstrongceilings.com/capabilities](http://armstrongceilings.com/capabilities)  
See more photos at:  
[armstrongceilings.com/photogallery](http://armstrongceilings.com/photogallery)

Durable metal vertical panels in multiple sizes with swivel attachment clips that allow for design flexibility.

## KEY SELECTION ATTRIBUTES

- new** • Four new Sequels™ pre-coat, wood-look finishes are part of the FAST134 program
- Now available in 17 Effects™ wood-look finishes
- Standard blade sizes in multiple lengths with either:
  - 4" depth and 1" width
  - 6" depth with 1" or 2" widths
- Premium blade sizes available:
  - Lengths up to 120"
  - Depths up to 10"
  - Widths 1" or 2"
- Available in 22-1/2", 46-1/2", 94-1/2", and 96" lengths for creative design layouts
- CleanAssure™ family of products – includes disinfectable panels, suspension systems, and trim
- Select products included in the FAST134 program – ready to ship in 4 weeks or less
- Blade panels available with either two factory-installed end caps, one end cap, or no end caps
- MetalWorks™ Blades – Classics panels are part of the Sustain™ portfolio (unperforated panels only)
- Create acoustical or non-acoustical upscale linear designs
- Fast, easy installation with standard Prelude® XL® 15/16" or 360° painted suspension systems

## END CAP DETAILS in Sequels Cape May Cherry

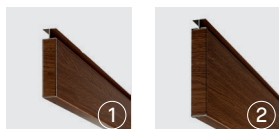

1. Factory-applied End Cap
2. Field-cut End Cap

# METALWORKS™ Blades – Classics

Linear Panels with Acoustical Options  
smooth texture



**LEED WELL | LBC**

**80% RECYCLED CONTENT**

- energy management
- construction waste mgmt
- regional materials
- design for flexibility
- EPD
- recyclable/producer resp.
- biobased materials
- recycled content
- sourcing of raw materials
- material ingredient reporting
- low emitting materials
- lighting quality
- acoustics

LOCATION DEPENDENT



MetalWorks™ Blades - Classics in Sequels Cape May Cherry

## STANDARD COLORS & FINISHES Due to printing limitations, shade may vary from actual product.

### Painted

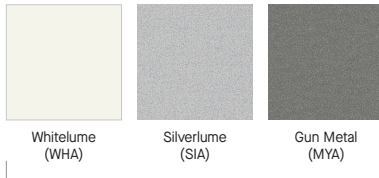

These colors are part of the Sustain™ portfolio (M1 – unperforated panels only)

### new Sequels™ Pre-coated Coil, Fast Lead Time



### Effects™ Classic Dye-Sublimation



### Effects™ Bold Dye-Sublimation



### Effects™ Subtle Dye-Sublimation



## CUSTOM COLORS & FINISHES



\* Colors that are pre-qualified to meet Sustain portfolio requirements are available upon request. Other made-to-order colors must be evaluated if sustainability criteria is required. Lead time will increase. For more information, visit our website at [armstrongceilings.com/metalworks](http://armstrongceilings.com/metalworks) or contact Architectural Specialties TechLine at 1 877 276-7876 for custom panel lengths. For premium requests contact ASQuote, ASQuote@armstrongceilings.com

## PERFORATION OPTIONS (1:2 scale shown)

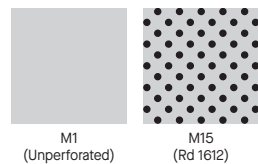

# METALWORKS™ Blades – Classics

Linear Panels with Acoustical Options  
smooth texture



Declare.

LEED WELL LBC  
80% RECYCLED CONTENT

- energy management
- construction waste mgmt
- regional materials
- design for flexibility
- EPD
- recyclable/extended producer resp.
- biobased materials
- recycled content
- sourcing of raw materials
- material ingredient reporting
- low emitting materials
- lighting quality
- acoustics

LOCATION DEPENDENT

## VISUAL SELECTION

## PERFORMANCE Dots represent high level of performance.

Item No. ◆	Description/ Dimensions D x W x L (Inches) Custom Sizes Available	
8157D41 8157D61 8157D62	Vertical panel with caps on both ends 4 x 1 x 94-1/2" 6 x 1 x 94-1/2" 6 x 2 x 94-1/2"	
8156D41 8156D61 8156D62	Vertical panel with caps on both ends 4 x 1 x 46-1/2" 6 x 1 x 46-1/2" 6 x 2 x 46-1/2"	
8155D41 8155D61 8155D62	Vertical panel with caps on both ends 4 x 1 x 22-1/2" 6 x 1 x 22-1/2" 6 x 2 x 22-1/2"	
7202D41 7202D61 7202D62	Vertical panel with cap on one end 4 x 1 x 96" 6 x 1 x 96" 6 x 2 x 96"	
7203D41 7203D61 7203D62	Vertical panel with no end caps 4 x 1 x 96" 6 x 1 x 96" 6 x 2 x 96"	

Fire Rating	CleanAssure™ Disinfectable Panels				DURABILITY		
	Fog	Spray	Wipe	Wash	Scrub	Soil	
Class A	•	•	•	•	•	•	
Class A	•	•	•	•	•	•	
Class A	•	•	•	•	•	•	
Class A	•	•	•	•	•	•	
Class A	•	•	•	•	•	•	

**FAST**  
4 WEEKS  
or Less

FAST134 program items ready to ship from manufacturer in 4 weeks or less. Up-to-date lead times and product options (sizes and colors) at [armstrongceilings.com/fast134](http://armstrongceilings.com/fast134)

◆ When specifying or ordering, include the appropriate perforation and color suffix with the item number (e.g., 8157D41 M15 E X C H).

## ACOUSTIC INFORMATION Dots represent high level of performance.

Blade	NRC					
	4" O.C.	6" O.C.	12" O.C.	16" O.C.	20" O.C.	24" O.C.
4" x 1"	0.55	0.45	0.25	0.20	0.20	0.15
6" x 1"	0.85	0.65	0.45	0.35	0.30	0.25
6" x 2"	1.05	0.80	0.50	0.40	0.35	0.30

## DESIGN EXAMPLES Multiple lengths and swivel attachment clip allow for design freedom. Below are some design layout examples from our MetalWorks Blades design guide.

1' x 4' Grid Layouts

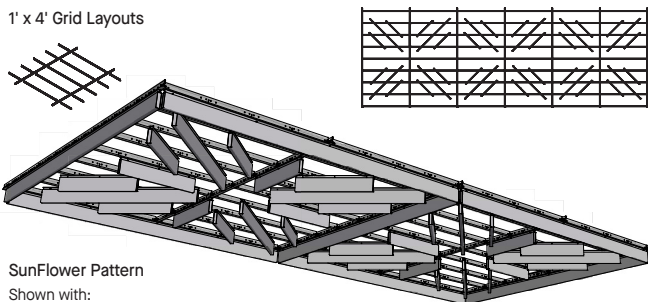

SunFlower Pattern  
Shown with:  
4 x 1 x 22-1/2" panels  
4 x 1 x 46-1/2" panels

4' x 4' Grid Layouts

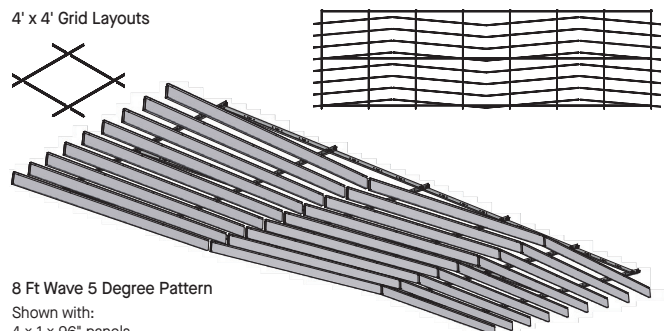

8 Ft Wave 5 Degree Pattern  
Shown with:  
4 x 1 x 96" panels

TechLine 877 276-7876

[armstrongceilings.com/metalworksbladesclassics](http://armstrongceilings.com/metalworksbladesclassics)

**Armstrong**  
World Industries



BLADES – Standard

# METALWORKS™ Blades – Classics

Linear Panels with Acoustical Options  
smooth texture



**LEED WELL LBC**

**80% RECYCLED CONTENT**

- energy management
- construction waste mgmt
- regional materials
- design for flexibility
- EPD
- recyclable/repairable producer resp.
- biobased materials
- recycled content
- sourcing of raw materials
- material ingredient reporting
- low emitting materials
- lighting quality
- acoustics



LOCATION DEPENDENT

## SUSPENSION SYSTEM & ACCESSORIES

	Item No. ♦	Description	Dimensions (Inches) Nominal L x W x H	Color	Pieces/Carton
Suspension Systems	7301_ _	Prelude® XL® 12' HD Main Beam	144 × 15/16 × 1-11/16"	White, Silver Grey, Gun Metal Grey*	20
	XL7341	Prelude XL 4' Cross Tee	48 × 15/16 × 1-11/16"	White, Silver Grey, Gun Metal Grey*	60
	XL8320	Prelude XL 2' Cross Tee	24 × 15/16 × 1-11/16"	White, Silver Grey, Gun Metal Grey*	60
	730136BL	Black 360 Prelude XL 12' HD Main Beam	144 × 15/16 × 1-11/16"	Black	20
	XL734036BL	Black 360 Prelude XL 4' Cross Tee	48 × 15/16 × 1-11/16"	Black	60
	XL732036BL	Black 360 Prelude XL 2' Cross Tee	24 × 15/16 × 1-11/16"	Black	60
Wall-to- Wall Installations	780036	12' Angle Molding	144 × 7/8 × 7/8"	Black, White*	30
	HD7801_ _	10' Angle Molding	120 × 7/8 × 7/8"	Silver Grey, Gun Metal Grey*	30
	BERC2	2" Beam End Retaining Clip	N/A	N/A	200
Floating Cloud Installations	AX6STR_ _ _ ♦	Axiom® Classic 6" Straight Trim	120 × 3/4 × 5-13/16"	White, Black, Silver Grey, Gun Metal Grey*	N/A
				Black is recommended for Sequels panel finishes	
	7239	Adjustable Trim Clip (ATC)	N/A	N/A	50
	5344_ _ _ _	4" Effects™ Wood Looks Trim	Nominal 120" Length	Effects Finishes	6
	5346_ _ _ _	6" Effects Wood Looks Trim	Nominal 120" Length	Effects Finishes	6

♦ Add the 2-digit color suffix to the item number when specifying or ordering (e.g. AX6STR S G), add an extra digit "3" before the color suffix if paint is required inside and outside of trim (e.g. AX6STR 3 S G).  
\* Items with the same finish name will coordinate but may not be an exact color match.

## ACCESSORIES

	Item No. ♦♦	Description	Color	Pcs/Ctn
	7204_ _	MetalWorks™ Blades – Classics Attachment Clip	Stainless Steel, Black Oxide	100
	7205D41 7205D61 7205D62	MetalWorks Blades – Classics 4" × 1" Alignment Device 6" × 1" Alignment Device 6" × 2" Alignment Device	N/A	24
	8158D41_ _ _ _ 8158D61_ _ _ _ 8158D62_ _ _ _	MetalWorks Blades – Classics 4" × 1" Field-Cut End Cap 6" × 1" Field-Cut End Cap 6" × 2" Field-Cut End Cap	Whitelume, Silverlume, Gun Metal, Sequels Finishes, Effects Finishes	10

♦♦ When specifying or ordering, include the color suffix with the item number (e.g., 8158D41 E X G H).

## SUSPENSION SYSTEMS

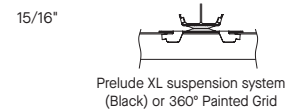

## PHYSICAL DATA

**Material**  
Aluminum – thickness 0.032"

**Surface Finish**  
Painted: Factory-applied polyester paint  
Sequels™: Pre-coated coil  
Effects™: Powder-coated, dye-sublimation, post-production finish

Custom colors and finishes also available. Contact TechLine for custom color matching requests at 1 877 276-7876.

**Fire Performance**  
Class A: Tested per ASTM E84. Flame Spread Index 25 or less. Smoke Developed Index 50 or less.  
CAN/ULC S102 surface burning characteristics. Flame Spread Rating 25 or less. Smoke Developed Classification 50 or less.

**Acoustical Options**  
Perforated panels are supplied with a black fiberglass fleece acoustic infill bag to absorb sound (varies by Blades panel length).

**Design Considerations**  
When installed, panels hang either 4-7/8" or 6-7/8" below the face of the grid, depending on the depth of Blade. Panels can be supported by intermediate duty main beams or cross tees, with 2 attachment clips per panel. See MetalWorks Blades – Classics design guide online for additional design layouts.  
MetalWorks Blades – Classics can be cut in the field only when using the Field-Cut End Cap. See installation instructions for details.

**Design Support**  
For custom design assistance contact ProjectWorks® Design Services or visit [armstrongceilings.com/projectworks](http://armstrongceilings.com/projectworks)

**Seismic Restraint**  
MetalWorks Blades – Classics are approved for application in all seismic areas when installed per the seismic guidelines in the Armstrong Ceilings installation instructions.

**FAST134 Program Considerations**  
Size of Job Matters: Big jobs, over 2500 SF or 50 pieces for shapes/vertical elements will have longer lead times.

**Location Matters:** Transit time not included. We are ready to ship in 1 week on FAST1 items. However, transit to the states west of Wyoming may add time.

**Distributor Truck Schedule Matters:** We rely on distribution to help move products around the country. When speed matters, work with your local distributor to ensure FAST134 service.

**Stock vs Made-to-Order Matters:** FAST3 & FAST4 items are made-to-order and will ship direct to distributor. FAST1 (stocked items) will go through distribution and depend on distributor truck schedules.

**Cleaning and Disinfecting**  
Cleaning and CDC-approved disinfecting options available on [armstrongceilings.com/cleaning](http://armstrongceilings.com/cleaning)

**Warranty**  
Details at [armstrongceilings.com/warranty](http://armstrongceilings.com/warranty)

**Weight**  
D41 panels: 0.50 LBS/LF  
D61 panels: 0.61 LBS/LF  
D62 panels: 0.68 LBS/LF

