



VidaShield UV24™ System for Ultima® Health Zone™

Seamlessly integrates with AcoustiBuilt ceilings to improve air quality

The Armstrong VidaShield UV24™ System pairs a UV-C Air Purifier with coordinating ceiling panels or LED lighting to offer safe, unobtrusive in-room air purification for cleaner air.

KEY SELECTION ATTRIBUTES

- Improves Indoor Air Quality
- Neutralizes 97% of allergens, viruses, and bacteria in the air on the first pass through the unit
- System uses shielded ultraviolet light and filtration to continuously draw air into a concealed chamber above the ceiling
- Treats intake air with a patented, scientifically proven VidaShield UV24™ technology and recirculates clean air back into the room
- Seamlessly integrates with popular Armstrong ceilings and suspension system finishes
- 24/7 continuous air cleaning reduces not only the spread of infectious aerosols through the air, but also settling back onto surfaces
- Incorporates patented, proven, VidaShield UV24™ technology
- Self-Contained UV-C Chamber is hidden in the ceiling plenum for safe use in occupied spaces
- Coordinates with Calla® Health Zone™, AirAssure™, Ultima® Health Zone™ AirAssure™, and School Zone® Fine Fissured™ AirAssure™ Ceilings for healthier spaces
- Treats 50 cu.ft./min. or 3,000 cu.ft./hr.
- LED light option combines an LED Light with Air Purification system
- Easy-to-install 2' x 4' system; minimal maintenance
- No staff intervention needed to operate UV-C Purification System
- 3-Year System Warranty
- Saves space occupied by portable air-cleaning units
- Perfect for retrofits in existing rooms
- Seamless integration options for drywall, AcoustiBuilt, exposed structure, and surface mount conditions with coordinating trim kits

COLOR



White (WH) Coordinates with Armstrong Suspension Systems

CEILING PANEL OPTIONS

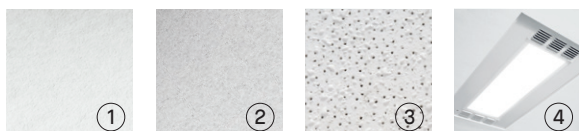

1. Calla® Health Zone™
2. Ultima® Health Zone™
3. School Zone® Fine Fissured™
4. LED light panel option

TYPICAL APPLICATIONS

- Healthcare – waiting rooms, patient rooms, hallways, break rooms, nurses stations, pharmacies
- Education – classrooms, cafeterias, labs
- Office – conference rooms, entryways/lobbies, break rooms, open plan seating areas
- Long-term care/Senior living
- Restaurants
- Daycare
- Retail

new VIDASHIELD UV24™ Air Purification System

VISUAL SELECTION

PACKAGING

	Item No.	Description	Dimensions	Pcs./Ctn.
new VidaShield UV24 Air Purification System Weight 31 lbs. Voltage 120-277, 0.6A, 50/60 Hz Class P / Damp Location Required power per unit = 60 watts	52UHZUVC	VidaShield UV24 System for Ultima® Health Zone™	48 × 24 × 5"	1
	52SZFFUVC	VidaShield UV24 System for School Zone® Fine Fissured™	48 × 24 × 5"	1
	52CHZUVC	VidaShield UV24 System for Calla® Health Zone™ (Coordinates with AcoustiBuilt and Drywall Ceilings)	48 × 24 × 5"	1

	Item No.	Description	Dimensions	LED Light Wattage	Driver	Lumens	CRI	Color Temp	Pcs./Ctn.
new VidaShield UV24 Air Purification System LED Light Panel Weight 34 lbs. Voltage 120-277, 1.3A, 50/60 Hz Class P / Damp Location Required power per unit = 120 watts Efficacy 100lm/W	52LUVC	VidaShield UV24 Air Purification System LED Light	48 × 24 × 5"	60	0-10 V Dimming*	7200	84.1	4000k	1

* Dimming control provided by others
 NOTE: The Armstrong VidaShield UV24 System is not a substitute for existing good building air exchange practices or manual cleaning and disinfection practices. Centrally locate, and position clean air outtake away from HVAC air returns for maximum benefit.

INSTALLATION AND MAINTENANCE KITS

	Item No.	Description
new Installation Kits	52EXPTK	VidaShield UV24 Exposed Trim Kit
	52DACBTK	VidaShield UV24 Drywall/AcoustiBuilt Trim Kit
	52SURMK	VidaShield UV24 Surface Mounting Kit
Maintenance Kits	51MK	VidaShield UV24 Air Purification System Maintenance Kit

NOTE: VidaShield must have the AirAssure sealing tape (item# 1350) applied to the unit in order to reduce air leakage points through the ceiling plane when installed with AirAssure tiles.

DETAIL DRAWINGS VidaShield UV24 is compatible with all 15/16" and 9/16" grid systems

Armstrong VidaShield UV24 Air Purification system

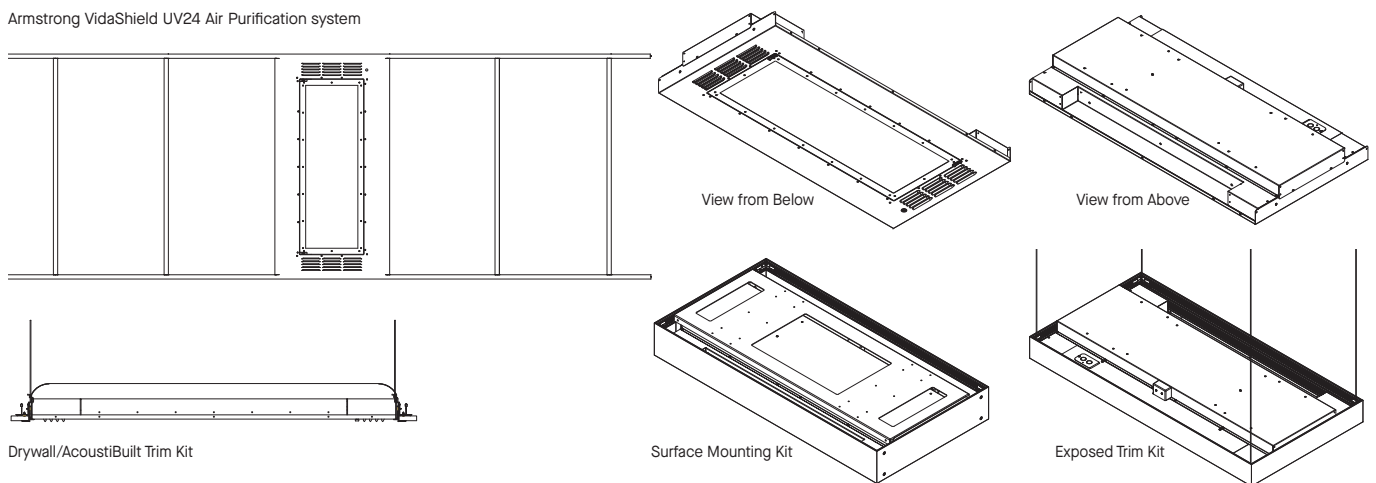

PHYSICAL DATA

Manufactured by Medical Illumination International, Inc. (MI), 19749 Dearborn Street, Chatsworth, CA 91311. Distributed by Armstrong World Industries



System efficacy and performance data based on testing, qualifications and studies from MI and its VidaShield UV24 product line.

Materials
 Aluminum, Steel
EPA Establishment Number
 94728-CA-1

UV-C Chamber
 - Air Filter MERV 6 high air flow particle filter
 - Switch deactivates UV bulb when accessed
 - Formed baffles prevent UV light leaks

Ceiling Panel Insert
 Mineral Fiber or LED Light

TechLine / 1 877 276-7876
 armstrongceilings.com/cleanair
 BPCS-6413-622

VidaShield UV24 is the property of Medical Illumination International, Inc.; all other trademarks used herein are the property of AWI Licensing LLC and/or its affiliates © 2023 AWI Licensing LLC

Armstrong®
 World Industries

CEILING THAT IMPROVE IAQ